

E I G E N W E L T   D E R  
A P P A R A T E - W E L T

PIONEERS OF ELECTRONIC ART

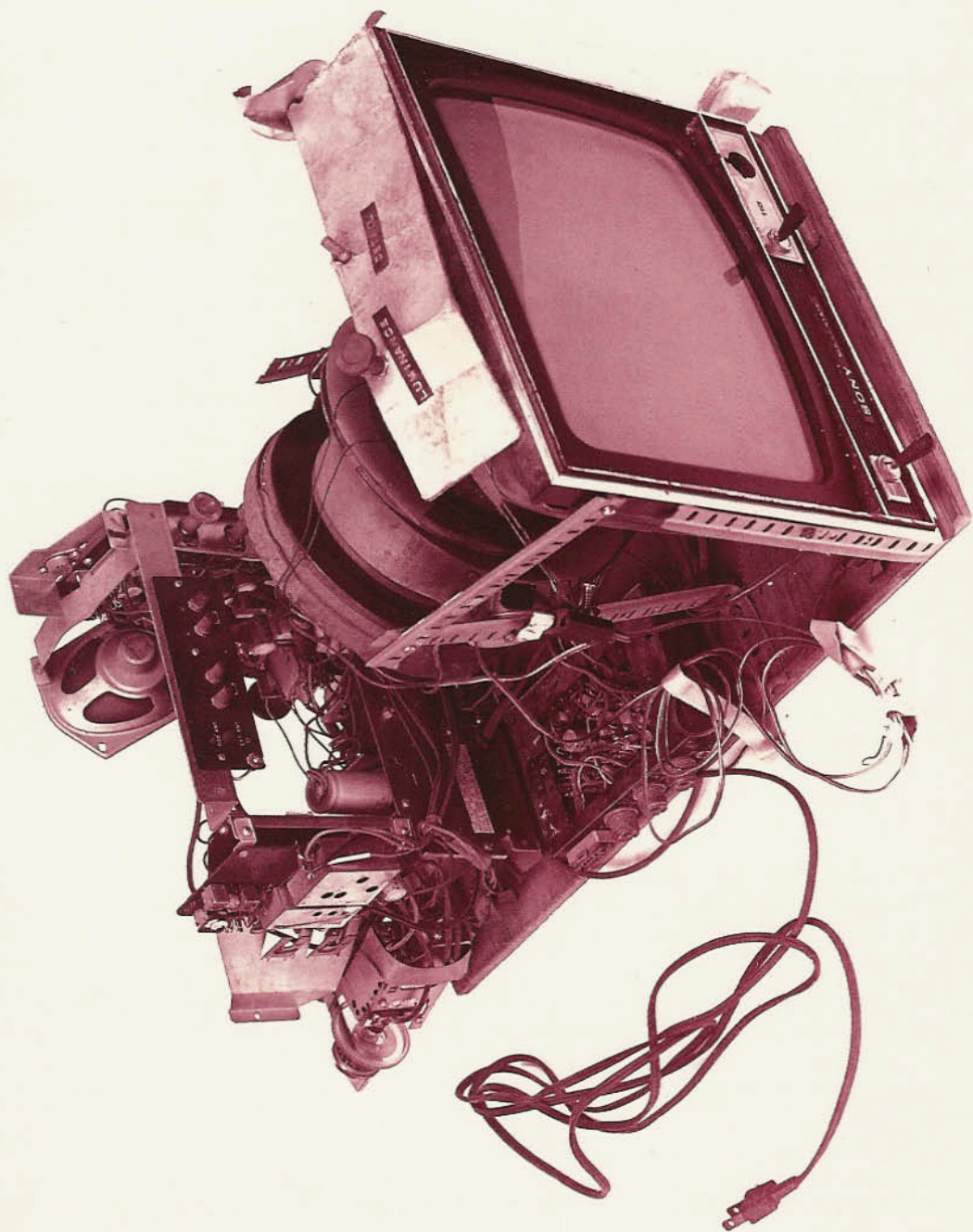

ARS ELECTRONICA 1992

E I G E N W E L T D E R  
A P P A R A T E W E L T  
P I O N I E R E D E R E L E K T R O N I S C H E N K U N S T

While the exhibition *Eigenwelt der Apparatwelt* focuses upon many of the pioneers of electronic arts through presenting some of the tools and instruments of a particular period of activity, it is essential to point out that this is a narrow slice of a much larger tradition. Since it has been impossible to be comprehensive, given the exhibition constraints and limited time, the catalog serves to provide a slightly larger context for the physical exhibits and an interactive link to its supplementary materials. In some cases the barcodes within the text provide access to visual and aural illustrations (on laserdisc) that are structurally intrinsic to the catalog text. In other circumstances they access materials which are supplementary and/or technical. Given its dual function, the catalog has been designed as both an interactive guide to the exhibition and as a stand alone collection of historical documents.

The first section of the catalog provides essential reading intended to provide an historical framework for the exhibition. The barcodes are generally correlated quite tightly to the information on laserdisc to provide a continuous reading experience.

—David Dunn, editor



**E A  
I P  
G P  
E A  
N R  
W A  
E T  
L E  
T -  
P I O N E E R S O F E L E C T R O N I C A R T  
W  
D E  
E L  
R T**

Artistic Director **PETER WEIBEL**

Curators **WOODY VASULKA** and **STEINA VASULKA**

Editor **DAVID DUNN**



ARS ELECTRONICA 1992

This catalog has been published on the occasion of the exhibition:

EIGENWELT DER APPARATEWELT  
PIONIERE DER ELEKTRONISCHEN KUNST

June 22 - July 5, 1992

Oberösterreichisches Landmuseum  
Francisco Carolinum, Linz

Artistic Director: Peter Weibel. Curators: Woody Vasulka and Steina Vasulka. Editor: David Dunn. Contributing Editors: Woody Vasulka and Steina Vasulka, Peter Weibel, MaLin Wilson, Jeffrey Schier. Project Coordinator: MaLin Wilson. Catalog Designer: Michael Sumner. Editorial Assistant: Melody Sumner. Technical Supervisor: David Muller.

Contact address: THE VASULKAS, INC., Route 6, Box 100, Santa Fe, New Mexico, 87501, USA.

Copyright ©1992 by The Vasulkas, Inc.

ARS ELECTRONICA

Management Committee: Karl Gerbel, Director (LIVA), Dr. Hannes Leopoldseder, Co-Founder(ORF), Peter Weibel, Artistic Director. Permanent Artistic Advisory Board: Dr. Katharina Gsöllpointner (LIVA), Mag. Brigitte Vasicek (LIVA), Dr. Christine Schöpf (ORF). Technician: Wolfgang Dorninger. Printer: Robert Wilk

Contact address: Brucknerhaus Linz, Linzer Veranstaltungsgesellschaft mbH (LIVA), Untere Donaulände 7, A-4010 Linz, Austria.

Exhibition Designers: Eichinger oder Knechtl, Vienna, Austria

*Cover: Rutt/Etra Scan Processor prototype, circa 1972. Collection of the Experimental Television Center, Ltd. & The State University of New York, Binghamton. Donated by Barbara Buckner. Photo: Dennis Dunda.*

*Frontispiece: Left to right, front row, Wendy Clarke, Jean-Pierre Boyer; Second row, Taka Imura, Woody Vasulka, Nam June Paik, Gerald O'Grady; Third row, Bill Viola, Ed Emshwiller, Kit Galloway, Steina Vasulka; Back, Walter Wright.*

## ACKNOWLEDGEMENTS

This exhibition and catalog were initiated and realized because of the enthusiasm and support of Peter Weibel, Artistic Director. We are also completely indebted to Ralph Hocking and Sherry Miller Hocking of the Experimental Television Center, Binghamton, for their extraordinary generosity in the assembly of the majority of the hardware and their careful attention to the myriad details of both hardware and archival information. Their professionalism and humor have been an inspiration and a pleasure.

Of course, we are especially grateful for the special efforts and cooperation of those inventors who personally excavated their past by agreeing to be interviewed, and by digging up schematics, photos, and dormant documents and, in many cases, by resuscitating their own machines. Thank you Stephen Beck, David Behrman, Don Buchla, Bob Diamond, Bill Etra, Lee Harrison, Bill Hearn, David Jones, Don McArthur, Nam June Paik, Steve Rutt, Dan Sandin, Jeff Schier, Eric Siegel, Glen Southworth, and Aldo Tambellini. We deeply regret that during this process we were never able to locate Shuya Abe and George Brown.

We also wish to acknowledge Steve Anderson, Michael Czajkovsky, Gary Hill, Norman Lowrey, and Sara Seagull for their extra efforts and assistance in lending significant audio/video instruments to the exhibition.

In addition to the subject of the interviews transcribed for this catalog, we acknowledge the following authors, editors and publications of the writings we have selected to print and reprint for this catalog:

- Arn, Robert. "The form and sense of video," *artscanada* (October 1973): 15-24.
- Beck, Stephen. "Image Processing and Video Synthesis." Lapis Technologies, Alameda, California. Typescript. 1975.
- Colorado Video, Inc. "Instruments for Video Art." Boulder, Colorado. Undated.
- Crutchfield, James P. "Space-Time Dynamics in Video Feedback." *Physica* 10D (1984). North-Holland, Amsterdam: Elsevier Science Publishers, North Holland Physics Publishing Division.
- DeWitt, Tom. Proposal for a video synthesizer. Typescript. 1975.
- Gill, Johanna Branson. "Video: State of the Art." *Working Papers*. New York: The Rockefeller Foundation, 1976.
- Harrison, Lee. Notes for an Animation Device, 1961. Photocopy.
- McArthur, Donald E. Introduction from "A Computer Based Video System," 1977. Typescript.
- Miller Hocking, Sherry and Richard Brewster. Chronology of the Experimental Television Center (1992), and *Image Processing Manual*. Typescript. Owego, New York: Experimental Television Center, 1978-1986.
- Paik, Nam June. "Binghamton Letter" to "Dear Friends at Radical Software." 8 January 1972. Binghamton, New York: Experimental Television Center.
- Rosebush, Judson. "The Moog Synthesizer: An Interview with Its Inventor." *Syracuse New Times* (February 17, 1972).
- Sandin, Daniel J. and Phil Morton. "Distribution Religion." Chicago: University of Illinois at Chicago Circle, ca. 1972.
- Tambellini, Aldo. Statement on BLACK SPIRAL. Flier for exhibition *TV as a Creative Medium* (May 17 - June 14, 1969). New York: Howard Wise Gallery.
- Yalkut, Jud. Excerpts from "PART THREE: OPEN CIRCUITS: The New Video Abstractionists" from unpublished book manuscript *ELECTRONIC ZEN: The Alternate Video Generation*, 1984.

Dear Catalog Reader:

## ABOUT THE BARCODES:

THE LIGHT PEN TOOL ITSELF IS CLUMSY, hard to hold for long without getting a severe pain in your wrist. You are to drag it over the barcode in the proper time intervals and speed, in the rhythm of the tango or the carrioca. At each “beep” you have succeeded. . . . If you don’t hear the beep, you can repeat the action going backwards or forwards. Keep on, please, don’t get embarrassed.

THERE ARE THREE KINDS of laserdiscs which are accessible from the catalog:

THE FIRST GROUP is found in laserstations labelled INFOSTATION, probably up to five of them located throughout this exhibit. These contain about two hundred *Still* images and up to twenty short *Moving* image segments, all related to the history and the performance of the *Instruments* described in the catalog. You will find the barcodes correlated to them in two sections of the catalog: *The Instruments* and in *Video: The State of the Art* article. Watch for a small label under the barcode itself, a tiny text shows INFO for orientation.

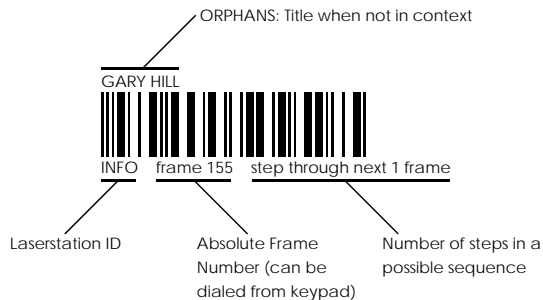

**THE SECOND GROUP** of laserdisc stations is visibly labeled **MUSIC** and they are located in quiet museum spaces. There will be at least two of them and they will hold *Still* images and *Moving* sections with actual samples of sounds, assembled by David Dunn to accompany his article in the catalog. All of the barcodes in the article entitled *A History of Electronic Music Pioneers*, are correlated to the **MUSIC** laserdisc.

**THE THIRD GROUP** of laserdisc stations are labeled **NANO-(THEATERS) A, B, and C**. They all have an identical *Still* image section as the Infostation, which means that you can access these stills from all stations except **MUSIC**. However, the *Moving* images on all discs are different. Even though you can also program the discs independently from the catalog by using the summary of all barcode information available at the stations, most of the disc information is available from within the catalog. For example, in the case of the *Light Music in the Soviet Union* article, the catalog will show a barcode labeled **NANO** informing of a stack of still pictures sitting there.

**NOW, IF YOU ARE BORED** by all of this, there is a *keypad* at each laserdisc station with a generic command set of instructions on their face. Just feel free to browse.

**BY THE WAY**, there is a space named **ENDO-THEATER** in this exhibit. It is programmed to play *tapes* selected by Steina: no *keypads*, no *barcodes*. —W.V.





## Curatorial Statement

IT WAS NO ACCIDENT when Peter Weibel called Steina and me last November with the question: Could you curate this show? Peter had met with Gene Youngblood and us here in Santa Fe at least twice - 1986 and 1987 - for the sole purpose of illuminating ourselves through ongoing discussions about the remarkable experience of early video which still seems to occupy our life so much. Peter, Gene, Steina and I have all gone through the "Media Activism" of the sixties which left us with a "front row view."

For me, video has not been an intellectual movement. Early protagonists Nam June Paik and Frank Gillette have given it an illusion of certain legitimacy, but no one has dealt with the formal concerns of media. My own interest was in confronting the syntax of film with the new video image, a concern that has not been addressed at all by the video movement. The criticism of media art has never risen from the shallow and sketchy.

Yet, I think, Peter's offer to us to curate an exhibition made some sense after all: Steina has a good personal video archive, and we have accumulated both general and custom/personal video instruments which map a certain line of aesthetic vocabularies (as they rather rapidly appeared in the early 1970's). We have also had a long standing interaction with their makers.

When we arrived in New York in the mid-1960's Steina and I were struck by two experiences: the American decadent movement and the aesthetic use of technology. We set out to explore both via video. Jackie Curtis took us through the *demimonde*; with George Brown and Eric Siegel we poked through

instruments - organizing Time and Energy. There were vast resources for our education, from LaMonte Young's drift oscillators to Automation House, from loft to loft, there was a state of creative frenzy - a lot of materials, new systemic thinking, another promise of techno-aesthetic utopia . . .

After Peter's call, our time got very short. It was mid-January when Ars Electronica confirmed and we assembled our team: MaLin Wilson (independent curator & writer), David Dunn (composer & writer), and David Muller (technician). I knew we needed to present not dead but live instruments - the earlier the instrument the better. We had to locate them, transport them and restore many. As I am writing this in mid-April, only God knows how this adventure will turn out.

On the other hand, many of those involved seemed to be just waiting for our call. Ralph Hocking, founder of the Experimental Television Center in Binghamton, New York, is now by default, the only large scale producer and facilitator of personalized, custom-built video instruments. By even greater default, Ralph and Sherry Miller Hocking are the only collectors and archivists of many of these instruments. Ralph picked up the phone as if we were having an uninterrupted conversation over the years.

We still haven't located Al Phillips to whom Eric Siegel entrusted his only video synthesizer. In a comparison to electronic audio instruments, there is no comparable historical or intellectual protocol to even consider the video instruments as cultural artifacts. While Paik's first synthesizer is still in the basement of MIT, the first Buchla box has just been

---

Photo: Woody at Columbia in the mid-sixties, fresh off the boat.

purchased from Mills College by a French institution.

It is a real pleasure to lift up a piece of scrap, to dust it off, return its name, restore it, insure it for thousands of dollars and publish it in an Austrian art catalogue!

**THE MYOPSIS:** Video infringed on our private lives, crowding our loft on Fourteenth Street. We established the Kitchen in 1971 to resolve that. Overnight we became part of a large network ranging from Europe to Japan to Canada.

Of course, the global character of the network did not help our own craft of making pictures electronically; that was helped by a very small tribe building circuits. This tribe is the subject of our exhibition. There was a legitimate underground technological community, with a life free enough to practice low budget experimentation and manufacturing. A new range of high frequency components appeared on the market at the same time that there was a dominant archetypical image commonly shared by the usage of hallucinogens. Finally, there was a generation of artists eager to practice the new witchcraft. And, indeed there was an audience . . .

It is important to note that besides these experiments with video, there was widespread practice of mixed media including television as closed circuit installations. And, of course, electronic sound making was in its golden era. It is even more important to understand that all of these forms of media work were being conducted against a full blown cultural background: painting, sculpture, poetry, music and film, to mention only a few. As insiders, the perspective we offer may be grossly exaggerated; nevertheless, that's what you, the viewer, will be getting.

Within the video movement our choices for this exhibition will look a bit odd. We are not going to show or describe works outside of the consideration of audio/video as electronic signal - that blessed state when it becomes accessible for alteration by electronic instruments. We are avoiding the essential and important pictorial and conceptual influences arising from "art as style" during the time period, from social influences and, from gallery and art market influences. We also believe that the most important works of art in video have been system-

atically presented by other curators. On the other hand, what we found more essential, more mysterious and unexplainable as newcomers from the "Old World" was the undefined spirit of American innovation and invention. To us it was all there was to do.

In the 1960's we used to distinguish between white collar and blue collar artists. Both of us came from socialist societies and would at "the tip of the hat" side with the working class. We thought the world was still material, even though we were handling metaphysical material - Time and Energy.

**THE TECHNOLOGY:** Besides the instruments, the essence of the exhibition is the images, both still and moving. In our private work we have advanced to the technological state of presenting our work on laserdisc. From the moment that we discovered a link between the laserdisc and the printed page through the barcode we knew it would suit the purpose of the exhibition magnificently. Despite the clumsy laserpen for reading the barcode and despite the time delay, we are convinced that this is a perfect marriage of method and subject.

**THE TAPES:** Steina has always been an avid collector of videotapes. Very early she was engaged in personal tape exchanges, a habit she still keeps. During the early days the urge to share unique discoveries drove people into almost compulsory communication videoletters, "how to's" and "look what I'm doing" were common, almost a genre. Many times we were the first on the receiving end, and today we are looking at an amazing assortment of tapes which forms the core of this exhibition.

There is an unprecedented affinity between electronic sound and image-making. Each generation of artists seems to come up with a tempting proposition of uniting the acoustic and the visual and vice versa - hoping once and for all to solve the mystery of audio-visual aesthetics. The generation that is the subject of our exhibition has gotten somewhat closer: even if the mystery of composing images with sounds was never revealed, this time the material, i.e. the frequencies, voltages and instruments which organized the material were identical. The advent and use of the oscillator became the natural link. As in our case, many of our colleagues and friends used audio oscillators of audio synthesizers to generate their first video images. The first video instruments

were inspired by the architecture of audio instruments, and the first organization of images was negotiated in similar ways. With feedback, which all these instruments possess generically, the preliminary nomenclature of generated images was established. The continuity between instruments of sound and instruments of image-making was basic to our conception of the exhibition in discussions with Peter Weibel. We also knew that there was a chance that the great weight of the cultural history of sound and music might tip the balance of the exhibition off center. So be it.

Woody Vasulka  
 Santa Fe, New Mexico  
 April, 1992

**R E G R E T S :**

Now, the time is up . . . I still regret that we did not get Tambellini's Black spiral working and that Beck's DVS would require such logistics to restore and present. I also guess that Siegel's EVA may still be intact and possibly alive. . . .

I also miss a "proper" historical background: Bauhaus, Czech kineticists, full summary of Ben Laposky, Mary Ellen Bute, the Whitneys in film and all the European video instrument builders: DePuouy, Richard Monkhouse and others involved in constructing and using electronic tools. What we have is only a preview to the ultimate show, to the mythical and forbidding "Project 2000," where the twentieth century will be thoroughly combed with a fine toothbrush.

—W.V. May, 1992

**E P I T A P H :**

Do I believe that video meant anything significant? Was it a legitimate art movement? Will it be remembered? I suppose if art in the future continues to be made electronically or becomes even more dependent on technology, then the history of this movement shall be secure. If, on the other hand, technology should be rejected in the art making of the near or distant future, the efforts of this tribe, "the tribe that worshipped electricity", (as Jonas Mekas put it), will certainly lapse into obscurity.

—W.V.



# THE APPARATUS WORLD—A WORLD UNTO ITSELF

P e t e r   W e i b e l

The development of modern art is inseparably linked to the notion of autonomous value. Autonomous value in the context of modern art implies the autonomous value of artistic mediums on which modern art makes its claim to autonomy. The discovery of the autonomous value of artistic material is a logical consequence of the onset of abstraction at the beginning of the 20th century. This value continued to increase exorbitantly.

At the end of the 19th century the autonomous value of color was discovered. A number of artists made statements testifying to the liberation of color as an autonomous medium. Maurice Denis (1896): "In keeping with my definition from 1890 the picture has become a surface on which color is arranged according to a certain principle." Vincent van Gogh: "I am totally absorbed by the laws of color - if we had only learned them in our youth! The true painters are those who do not create local colors, that was what Ch. Blanc and Delacroix spoke about one day. The painter of the future, he is a colorist as there never was before him."

Eugène Delacroix was accused by Maxime Du-camp of the following: "Semblable à certains littérateurs qui ont créé l'art pour l'art, M. Delacroix a inventé la couleur pour la couleur." Cézanne, the father of cubism destroyed the object by adhering only to the logic of color and coloristic construction: "Il y a une logique colorée, parbleu. Le peintre ne doit obéissance qu'à elle." Painters never ceased to preach the abstraction of color from the object. Paul Gauguin: "La couleur pure! Et il faut tout lui sacrifier. (Don't work so much after nature. Art is abstraction.)" The liberation of color from its representative function, from its local color led to the abstraction of color from the object. This abstraction of color, this triumph of the autonomous value of color led ultimately to the object being banned from the

picture by abstraction. The abstracted autonomous value of color laid the foundation for abstract non-representational art.

This analysis of color on the basis of the dispersion of light was influenced by scientific works such as:

Charles Blanc, *Grammaire des arts du dessin* (1867).

Michel Eugene Chevreul, *De la loi du contraste simultané des couleurs* (1839). Translated into English as *The Principles of Harmony and Contrast of Colours, and Their Application to the Arts* (London, 1854).

Ogden N. Rood, *Modern Teaching of Colors* (1881).

Charles Henry, *A Scientific Aesthetics* (1885).

The analysis of color not only increased the autonomous value of color, of the material, it also increased that of the method. Painting was no longer a personal, romantic improvisation but a scientific method. "I paint my method," Seurat said, "nothing else." Paul Adams wrote in 1886: "Through uncompromising application of a scientific representation of color and its strange innovative qualities Pissarro, Signac and Seurat ostentatiously represent the definite trend of impressionistic art." In 1887 Pissarro called himself a "scientific impressionist", looking for art "that is in keeping with our times." Félix Fénéon described the post-impressionist technique as a "conscious and scientific style, an impersonal and in a certain sense abstract treatment."

The discovery of the intrinsic quality of color ushered in abstraction. Abstract painting became an autonomous world of colors and forms. The break with the outside world, the ban of the object, the rejection of external references automatically

resulted in an obsession with the laws of the newly discovered world (of color). The autonomous value of color called for a scientific, non-subjective method. Overcoming the subjectivity (of impressionism) and the signature of the painter, the scientific grounding of painting on the objective laws of vision, color and light were the expressed goals of post-impressionism, divisionism and pointillism. These intentions of painting at the end of the 19th century were also already the premises of photography since the mid-19th century. We can assume that this development of painting to autonomous worlds of color and surface, lines and forms and the grounding of painting on a scientific method and depersonalization was influenced by photography, the machine production of images.

Further stages of modern art in its search for greater autonomy, making the emancipation of its constitutive elements, were the preoccupation with the autonomous value of light (Robert Delaunay, 1912, to Zdenek Pesánek, the father of light kinetism, who introduced real neon light in 1933) and to the preoccupation with the autonomous value of the material (from Tatlin to Beuys). In his preoccupation with the autonomous value of material, Tatlin had come close to machine art, parallel to the machine art of the abstract avant-garde film of the twenties. (See the banner made by R. Hausmann and G. Grosz: "Long Live Tatlin's machine art.")

After the elimination of the external reference through the ban imposed on the object, a phase followed in which the external reference was replaced by an inner reference. The non-objective colors and forms began to represent internal states (e.g., the world of the soul) instead of external states (e.g., the world of objects). Abstraction briefly became a doctrine of signs for structures of existence, the soul, the cosmos. This internal reference, however, was already attacked by the Russian Constructivists and Productivists. After the external reference had been eliminated, the internal one was done away with as well, and art became self-referential. Through the gradual emancipation of all of its elements as autonomous values and autonomous methods, art began to produce worlds of its own. The declarations of independence of color and form on which the autonomy of modern art was based entailed new aesthetic strategies such as depersonalization, deletion of the artist's signature and scientific methods of production befitting in keeping with the times. All of this, however, was more an aesthetic grammar introduced by photography than with that of painting, the former representing the notorious grammar of machine-based production of imagery.

Machine and machine-supported media art is not only a logical consequence of the visual arts, it is indeed the prerequisite of modern art. In 1839 (after the invention of Daguerre photography) Paul Delaroche put it somewhat ambivalently: "From now on painting is dead." This, of course, refers to historical painting. The introduction of machines in the world of art revolutionized art and

founded modernity. Here I will try to explain why there is still such a strong ideological resistance to machine and media art. It has to do with what is genuine about modern art but also what makes it disquieting: its autonomy. Machine-supported art also radically implicates the independence of machines from man.

Photography brings a new definition of the author into play which is irreconcilable with the classical definition of the author as *deus artifex*, as the one and only God of creation. Already the father of modern photography, i.e., the positive/negative procedure, Fox W. H. Talbot pointed to an axiomatic disappearance in his first publication ("Some Account of the Art of the Photogenic Drawing, or, the Process by which Natural Objects May be Made to Delineate Themselves without the Aid of the Artist's Pencil" in: *Royal Society Proceedings*, IV, 1839, p. 120f and in: *Philosophical Magazine*, XIV, 1839, pp. 196-208). The disappearance that he was referring to was that of the pencil (or of the hand) of the artist. In a letter written in 1839 he describes what replaces the artist, the automation: "...that by means of this device [the photo camera] it is no longer the artist who makes the picture but it is the picture that makes itself. The artist does not have to do more than set up the device in front of the object, the picture of which he wants." The device makes the picture - by itself is "auto" in Greek. The photographic device is thus an automatic and autonomous machine. By means of the autonomous mechanism of this device an image is made without the artist. The machine has become a rival of man in creating a work. The machine as an autonomous producer provides a first and fundamental model for all the autonomy movements that followed in modern art. The first stage of the "autonomous" image was the machine-supported production of images in photography (1839). The transmission of images over long distances (telegraphy) by means of the scanning principle, the dissolution of a two-dimensional image in a linear sequence of temporal points took place at about the same time. The separation of messenger and message in the electromagnetic age (1873: Maxwell; 1887: Hertz; 1896: Marconi) made it possible to produce signs without a body or material in a telematic culture. It also resulted in the disappearance of space and time. Telephone, telecopier, the "electronic telescope" (TV system, developed by P. Nipkow in 1884) are systems for transmitting sound as well as static and dynamic images. The machine-supported generation of images was followed by the machine-supported transmission of images (second stage). Machine-moved images, film, the illusion of the moving image, were the third stage.

The discovery of the electron and the cathode-ray tube (both 1897) provided the basis for the electronic production and transmission of images. The magnetic recording of the image signals (instead of sound signals as before) by means of the video recorder (1951) combined film and TV (image storage and emission) in the new medium of video. This fourth "stage" increased the possibilities of manipulating the image by means of machines. This

exhibition "The Apparatus World - A World unto Itself" shows the wide range of these sound and image worlds, where the signal itself is no longer a carrier for depicting the object world but rather the image itself; autonomous worlds of sound and image that can be manipulated by both the observer and the machine. An artificial world of sound and images is emerging, one which can be generated by machines alone. These worlds can serve as a model for further artificial realities. The fifth stage - the machine-generated, calculable image of the computer - unites not only the characteristics of all the four stages of technical imagery but also reveals new characteristics: virtuality and interactivity. Interactive computer installations and simulations facilitate the illusion of the "animated" image as the presently most advanced stage of development in the art of the technical image. The interactive "animated" image is perhaps the most radical transformation of the understanding of image in the western world.

The scandal of machine-supported art, from photography, video, to the computer, uncovers the fiction that art is a human place, a place for human creativity, unique individuality. Machine art mocks this bourgeois illusion in an unrelenting way. Fox Talbot already sensed this. Even though he explicitly states in the title of his first paper that the traditional tools of art had disappeared and that the image was now made by the machine itself instead of the artist, he sensed an ideological resistance to the exclusion of the subject. Instead of calling his main work "The Pencil of Machine" he gave it the wrong title "The Pencil of Nature" (1844) and this in spite of the fact that he understood the autonomous value of photography. Talbot does not mention the machine, the *raison d'être* of photography. To the contrary, he transfigured it in ideological fury to a work of nature, if not of God. This way the sovereignty of the bourgeois subject remained untouched, at least in ideological terms. The autonomy of the photographic machine was the first model of "autonomy" to trigger the logic of modern art, which consisted in the progressive development of its autonomous elements. The three stages included 1) analysis and shift of focus (stressing or neglecting a specific aspect), 2) emancipation and absolutization (leaving out or absolute primacy of an element), 3) substitution and exclusion (exchanging or replacing an element). In modern art this was reflected in the development of different "own" worlds, from the intrinsic quality of color to that of light and that of material. This autonomous nature of the mediums of modern art provided the basis for the autonomy of art, but at the same time also posed a threat to it. The autonomous world of apparatus stands at the beginning and at the end of this development. From the outset media art endorsed the concept of autonomy of its world, its values and laws. In this respect it is part of the prerequisites, history and future of art. The world of the apparatus as a world unto itself does not just follow the logic of modernism, it has also created its conditions and context. This is what accounts for the self-referentiality of modern art. As Fox Talbot alludes to, machine



art did away with the dualism of image and object, because here the apparatus is explicitly inserted between them:



Whereas the artist's hand could traditionally be neglected as a machine, this was no longer the case in photography. In a second stage, apparatus art eliminated the object and images could now only be generated by machines. Here is where autonomous worlds of images began to emerge.



The classical ontological aesthetic

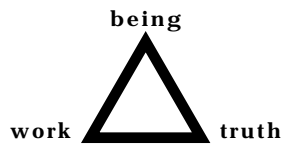

became a semiotic aesthetic.

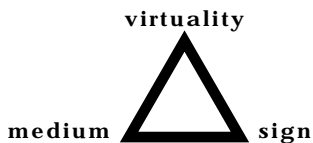

The world of apparatus world continues what painting began, what it was forced to do by machines and what painting was unable to fulfill: the emancipation of all elements from art, giving rise to various worlds with intrinsic laws and qualities. By the same token, media art is a continual (postmodern) redefinition of the project of modernity. Non-identity, context, interactivity, observer have replaced identity, text, closure, author. That this heroic art of the apparatus world meets with resistance and protest, even though it has founded the logic of modernity to which it adheres, can only be explained by the ideological ban motivated by man's fear of the void created in modern civilization and modern art by the autonomy of the machine and the disappearance of a familiar reality.

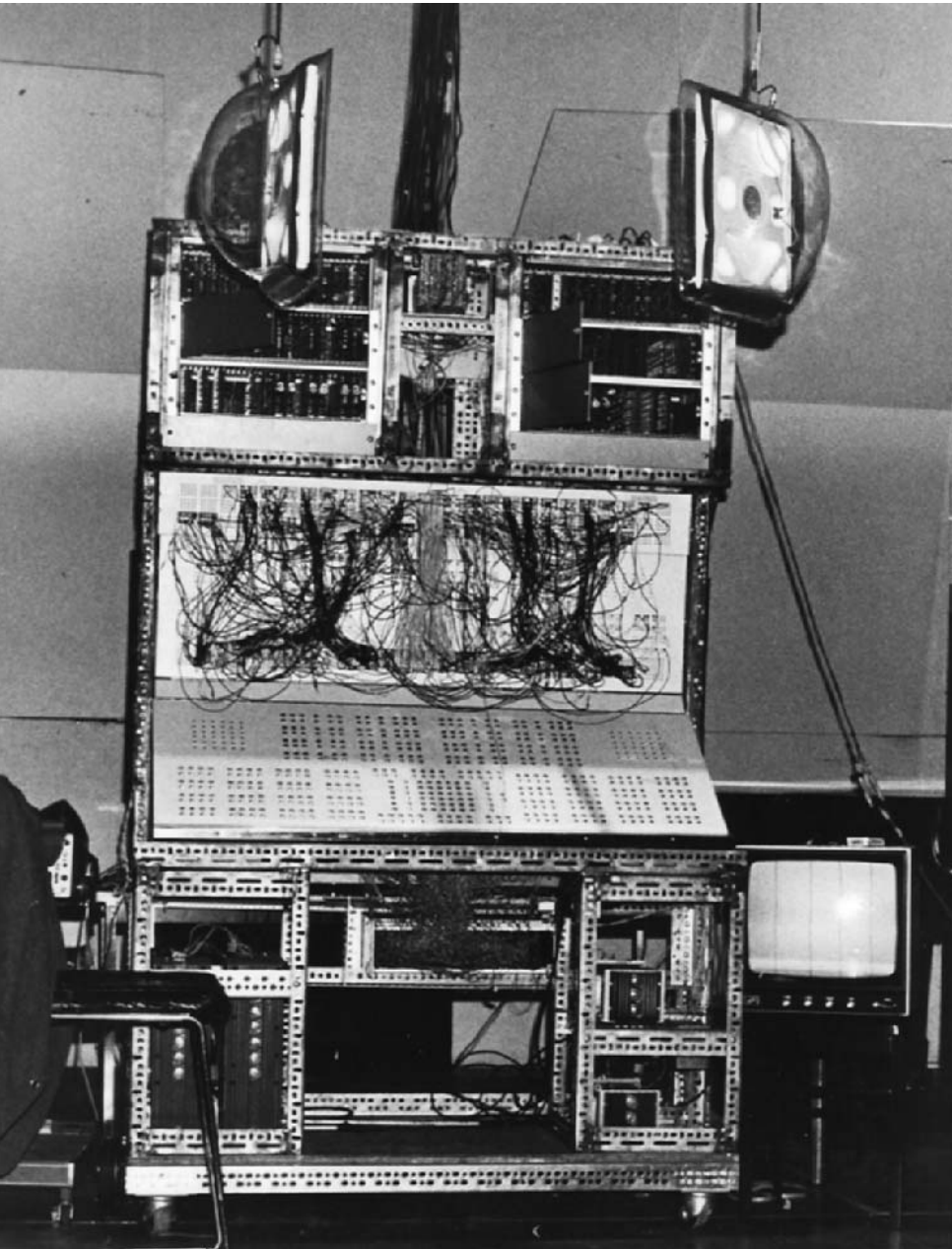

# A HISTORY OF ELECTRONIC MUSIC PIONEERS

David Dunn

*“When intellectual formulations are treated simply by relegating them to the past and permitting the simple passage of time to substitute for development, the suspicion is justified that such formulations have not really been mastered, but rather they are being suppressed.”*

—Theodor W. Adorno

*“It is the historical necessity, if there is a historical necessity in history, that a new decade of electronic television should follow to the past decade of electronic music.”*

—Nam June Paik (1965)

## INTRODUCTION:

Historical facts reinforce the obvious realization that the major cultural impetus which spawned video image experimentation was the American Sixties. As a response to that cultural climate, it was more a perceptual movement than an artistic one in the sense that its practitioners desired an electronic equivalent to the sensory and physiological tremendums which came to life during the Vietnam War. Principal among these was the psychedelic experience with its radical experiential assault on the nature of perception and visual phenomena. Armed with a new visual ontology, whatever art image-making tradition informed them it was less a cinematic one than an overt counter-cultural reaction to television as a mainstream institution and purveyor of images that were deemed politically false. The violence of technology that television personified, both metaphorically and literally through the war images it disseminated, represented a source for

renewal in the electronic reconstruction of archaic perception.

It is specifically a concern for the expansion of human perception through a technological strategy that links those tumultuous years of aesthetic and technical experimentation with the 20th century history of modernist exploration of electronic potentials, primarily exemplified by the lineage of artistic research initiated by electronic sound and music experimentation beginning as far back as 1906 with the invention of the Telharmonium. This essay traces some of that early history and its implications for our current historical predicament. The other essential argument put forth here is that a more recent period of video experimentation, beginning in the 1960's, is only one of the later chapters in a history of failed utopianism that dominates the artistic exploration and use of technology throughout the 20th century.

The following pages present an historical context for the specific focus of this exhibition on early pioneers of electronic art. Prior to the 1960's, the focus is, of necessity, predominantly upon electronic sound tool making and electroacoustic aesthetics as antecedant to the more relevant discussion of the emergence of electronic image generation/processing tools and aesthetics. Our intention is to frame this image-making tradition within the realization that many of its concerns were first articulated within an audio technology domain and that they repeat, within the higher frequency spectrum of visual information, similar issues encountered within the electronic music/sound art traditions. In fact, it can be argued that many of the innovators within this period of electronic image-making evolved directly from participation in the

electronic music experimentation of that time period.

Since the exhibition itself attempts to depict these individuals and their art through the perspective of the actual means of production, as exemplified by the generative tools, it must be pointed out that the physical objects on display are not to be regarded as aesthetic objects per se but rather as instruments which facilitate the articulation of both aesthetic products and ideological viewpoints. *It is predominantly the **process** which is on exhibit.* In this regard we have attempted to present the ideas and artwork which emerged from these processes as intrinsic parts of ideological systems which must also be framed within an historical context. We have therefore provided access to the video/audio art and other cultural artifacts directly from this text (i.e., barcodes) as it unfolds in chronological sequence. Likewise, this essay discusses this history with an emphasis on issues which reinforce a systemic process view of a complex set of dialectics (e.g. modernist versus representationist aesthetics, and artistic versus industrial/technocratic ideologies).

#### EARLY PIONEERS :

One of the persistent realities of history is that the facts which we inherit as descriptions of historical events are not neutral. They are invested with the biases of individual and/or group participants, those who have survived or, more significantly, those who have acquired sufficient power to control how that history is written. In attempting to compile this chronology, it has been my intention to present a story whose major signposts include those who have made substantive contributions but remain uncelebrated, in addition to those figures who have merely become famous for being famous. The reader should bear in mind that this is a brief chronology that must of necessity neglect other events and individuals whose work was just as valid. It is also an important feature of this history that the artistic use of technology has too often been criticized as an indication of a de-humanizing trend by a culture which actually embraces such technology in most other facets of its deepest fabric. It appears to abhor that which mirrors its fundamental workings and yet offers an alternative to its own violence. In view of this suspicion I have chosen to write this chronology from a position that regards the artistic acquisition of technology as one of the few arenas where a creative critique of the so-called technological era has been possible.

One of the earliest documented musical instruments based upon electronic principles was the CLAVECIN ÉLECTRIQUE designed by the jesuit priest Jean-Baptiste Delaborde in France, 1759. The device used a keyboard control based upon simple electrostatic principles.

All barcodes in this article pertain to the MUSIC stations.





The spirit of invention which immediately preceded the turn of this century was synchronous with a cultural enthusiasm about the new technologies that was unprecedented. Individuals such as Bell, Edison, and Tesla became culture heroes who ushered in an ideology of industrial progress founded upon the power of harnessed electricity. Amongst this assemblage of inventor industrialists was DR. THADDEUS CAHILL, inventor of the electric typewriter, designer and builder of the first musical synthesizer and, by default, originator of industrial muzak. While a few attempts to build electronic musical instruments were made in the late 19th century by Elisha Gray, Ernst Lorenz, and William Duddell, they were fairly tentative or simply the curious byproducts of other research into electrical phenomena. One exception was the musical instrument called the CHORALCELO built in the United States by Melvin L. Severy and George B. Sinclair between 1888 and 1908. Cahill's invention, the TELHARMONIUM, however, remains the most ambitious attempt to construct a viable electronic musical instrument ever conceived.

Working against incredible technical difficulties, Cahill succeeded in 1900 to construct the first prototype of the TELHARMONIUM and by 1906, a fairly complete realization of his vision. This electro-mechanical device consisted of 145 rheotome/alternators capable of producing five octaves of variable harmonic content in imitation of orchestral tone colors. Its principal of operation consisted of what we now refer to as additive synthesis and was controlled from two touch-sensitive keyboards capable of timbral, amplitude and other articulatory selections. Since Cahill's machine was invented before electronic amplification was available he had to build alternators that produced more than 10,000 watts. As a result the instrument was quite immense, weighing approximately 200 tons. When it was shipped from Holyoke, Massachusetts to New York City, over thirty railroad flatcars were enlisted in the effort.

While Cahill's initial intention was simply to realize a truly sophisticated electronic instrument that could perform traditional repertoire, he quickly pursued its industrial application in a plan to provide direct music to homes and offices as the strategy to fund its construction. He founded the New York Electric Music Company with this intent and began to supply realtime performances of popular classics to subscribers over telephone lines. Ultimately the business failed due to insurmountable technical and legal difficulties, ceasing operations in 1911.

The Telharmonium and its inventor represents one of the most spectacular examples of one side of a recurrent dialectic which we will see demonstrated repeatedly throughout the 20th century history of the artistic use of electronic technology. Cahill personifies the industrial ideology of invention which seeks to imitate more efficiently the status quo. Such an ideology desires to



summarize existent knowledge through a new technology and thereby provide a marketable representation of current reality. In contrast to this view, the modernist ideology evolved to assert an anti-representationist use of technology which sought to expand human perception through the acquisition of new technical means. It desired to seek the unknown as new phenomenological and experiential understandings which shattered models of the so-called "real".

The modernist agenda is brilliantly summarized by the following quote by Hugo Ball:

*"It is true that for us art is not an end in itself, we have lost too many of our illusions for that. Art is for us an occasion for social criticism, and for real understanding of the age we live in...Dada was not a school of artists, but an alarm signal against declining values, routine and speculations, a desperate appeal, on behalf of all forms of art, for a creative basis on which to build a new and universal consciousness of art."*

Many composers at the beginning of this century dreamed of new electronic technologies that could expand the palette of sound and tunings of which music and musical instruments then consisted. Their interest was not to use the emerging electronic potential to imitate existant forms, but rather to go beyond what was already known. In the same year that Cahill finalized the Telharmonium and moved it to New York City, the composer FERRUCCIO BUSONI wrote his *Entwurf einer neuen Ästhetik der Tonkunst* (Sketch of a New Aesthetic of Music) wherein he proposed the necessity for an expansion of the chromatic scale and new (possibly electrical) instruments to realize it. Many composers embraced this idea and began to conceptualize what such a music should consist of. In the following year, the Australian composer PERCY GRAINGER was already convinced that his concept of *FREE MUSIC* could only be realized through use of electro-mechanical devices. By 1908 the Futurist Manifesto was published and the modernist ideology began its artists' revolt against existant social and cultural values. In 1913 Luigi Russolo wrote *The Art of Noise*, declaring that the "evolution of music is paralled by the multiplication of the machine". By the end of that year, RUSSOLO AND UGO PIATTI had constructed an orchestra of electro-mechanical noise instruments (intonarumori) capable of realizing their vision of a sound art which shattered the musical status quo. Russolo desired to create a sound based art form out of the noise of modern life. His noise intoning devices presented their array of "howlers, boomers, cracklers, scrapers, exploders, buzzers, gurglers, and whistles" to bewildered audiences in Italy, LONDON, and finally Paris in 1921, where he gained the attention of Varèse and Stravinsky. Soon

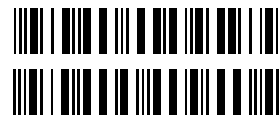

after this concert the instruments were apparently only used commercially for generating sound effects and were abandoned by Russolo in 1930.

Throughout the second decade of the 20th century there was an unprecedented amount of experimental music activity much of which involved discourse about the necessity for new instrumental resources capable of realizing the emerging theories which rejected traditional compositional processes. Composers such as Ives, Satie, Cowell, VARÈSE, and Schoenberg were advancing the structural and instrumental resources for music. It was into this intellectual climate, and into the cultural changes brought on by the Russian Revolution, that LEON THEREMIN (Lev Sergeyeovich Termen) introduced the Aetherophone (later known as the Theremin), a new electronic instrument based on radio-frequency oscillations controlled by hands moving in space over two antennae. The extraordinary flexibility of the instrument not only allowed for the performance of traditional repertoire but also a wide range of new effects. The theatricality of its playing technique and the uniqueness of its sound made the Theremin the most radical musical instrument innovation of the early 20th century.

The success of the Theremin brought its inventor a modest celebrity status. In the following years he introduced the instrument to Vladimir Lenin, invented one of the earliest television devices, and moved to New York City. There he gave concerts with Leopold Stokowski, entertained Albert Einstein and married a black dancer named Lavinia Williams. In 1932 he collaborated with the electronic image pioneer MARY ELLEN BUTE to display mathematical formulas on a CRT synchronized to music. He also continued to invent new instruments such as the Rhythmicon, a complex cross-rhythm instrument produced in collaboration with HENRY COWELL. Upon his return to the Soviet Union in 1938, Theremin was placed under house arrest and directed to work for the state on communications and surveillance technologies until his retirement in the late 1960's.

In many ways, Leon Theremin represents an archetypal example of the artist/engineer whose brilliant initial career is coopted by industry or government. In his case the irony is particularly poignant in that he invented his instruments in the full flowering of the Bolshevik enthusiasm for progressive culture under Lenin and subsequently fell prey to Stalin's ideology of fear and repression. Theremin was prevented until 1991 (at 95 years of age) from stepping foot outside the USSR because he possessed classified information about radar and surveillance technologies that had been obsolete for years. This suppression of innovation through institutional ambivalence, censorship or co-optation is also one of the recurrent patterns of the artistic use of technology throughout the 20th century. What often begins with the desire to expand human perception ends with commoditization or direct



repression.

By the end of the 1920's a large assortment of new electronic musical instruments had been developed. In Germany JÖRG MAGER had been experimenting with the design of new electronic instruments. The most successful was the SPHÄROPHON, a radio frequency oscillator based keyboard instrument capable of producing quarter-tone divisions of the octave. Mager's instruments used loudspeakers with unique driver systems and shapes to achieve a variety of sounds. Maurice Martenot introduced his Ondes Martenot in France where the instrument rapidly gained acceptance with a wide assortment of established composers. New works were written for the instrument by Milhaud, Honegger, Jolivet, VARÈSE and eventually MESSIAEN who wrote *Fête des Belles Eaux* for an ensemble of six Ondes Martenots in 1937 and later as a solo instrument in his *3 PETITES LITURGIES* of 1944. The Ondes Martenot was based upon similar technology as the Theremin and Sphärophon but introduced a much more sophisticated and flexible control strategy.

Other new instruments introduced around this time were the Dynaphone of Rene Bertrand, the Hellertion of Bruno Helberger and Peter Lertes, and an organlike "synthesis" instrument devised by J. Givelet and E. Coupleaux which used a punched paper roll control system for audio oscillators constructed with over 700 vacuum tubes. One of the longest lived of this generation of electronic instruments was the TRAUTONIUM of Dr. Friedrich Trautwein. This keyboard instrument was based upon distinctly different technology than the principles previously mentioned. It was one of the first instruments to use a neon-tube oscillator and its unique sound could be selectively filtered during performance. Its resonance filters could emphasize specific overtone regions. The instrument was developed in conjunction with the Hochschule für Music in Berlin where a research program for compositional manipulation of phonograph recordings had been founded two years earlier in 1928. The composer PAUL HINDEMITH participated in both of these endeavors, composing a *Concertino for Trautonium and String Orchestra* and a sound montage based upon phonograph record manipulations of voice and instruments. Other composers who wrote for the Trautonium included Richard Strauss and Werner Egk. The greatest virtuoso of this instrument was the composer OSKAR SALA who performed on it, and made technical improvements, into the 1950's. Also about this time, the composer Robert Beyer published a curious paper about "space" or "room music" entitled *Das Problem der Kommender Musik* that gained little attention from his colleagues (Beyer's subsequent role in the history of electronic music will be discussed later).

The German experiments in phonograph manipulation constitute one of the first attempts at organizing sound electronically

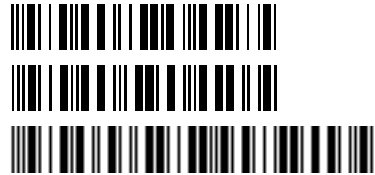

that was not based upon an instrumental model. While this initial attempt at the stipulation of sound events through a kind of sculptural moulding of recorded materials was short lived, it set in motion one of the principle approaches to electronic composition to become dominant in decades to come: the electronic music studio. Other attempts at a non-instrumental approach to sound organization began in 1930 within both the USSR and Germany. With the invention of optical sound tracks for film a number of theorists become inspired to experiment with synthetic sound generated through standard animation film techniques. In the USSR two centers for this research were established: A.M. Avzaamov, N.Y. Zhelinsky, and N.V. VOINOV experimented at the Scientific Experimental Film Institute in Leningrad while E.A SCHOLPO and G.M. Rimski-Korsakov performed similar research at the Leningrad Conservatory. In the same year, Bauhaus artists performed experiments with hand-drawn waveforms converted into sound through photoelectric cells. Two other German artists, RUDOLPH PFENNINGER and OSCAR FISCHINGER worked separately at about this time exploring synthetic sound generation through techniques that were similar to Voinov and Avzaanov.

A dramatic increase in new electronic instruments soon appeared in subsequent years. All of them seem to have had fascinating if not outrightly absurd names: the Sonorous Cross; the ELECTROCHORD; the Ondioline; the CLAVIOLINE; the Kaleidophon; the Electronium Pi; the Multimonica; the Pianophon; the Tuttivox; the Mellertion; the Emicon; the Melodium; the Oscillion; the Magnetton; the Photophone; the Orgatron; the Photona; and the PARTITUROPHON. While most of these instruments were intended to produce new sonic resources, some were intended to replicate familiar instrumental sounds of the pipe organ variety. It is precisely this desire to replicate the familiar which spawned the other major tradition of electronic instrument design: the large families of electric organs and pianos that began to appear in the early 1930's. LAURENS HAMMOND built his first electronic organ in 1929 using the same tone-wheel process as Cahill's Telharmonium. Electronic organs built in the following years by Hammond included the NOVACHORD and the Solovox. While Hammond's organ's were rejected by pipe organ enthusiasts because its additive synthesis technique sounded too "electronic," he was the first to achieve both stable intonation through synchronized electromechanical sound generators and mass production of an electronic musical instrument, setting a precedent for popular acceptance. Hammond also patented a spring reverberation technique that is still widely used.

The Warbo Formant Organ (1937) was one of the first truly polyphonic electronic instruments that could be considered a predecessor of current electronic organs. Its designer the German

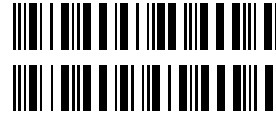

engineer HARALD BODE was one of the central figures in the history of electronic music in both Europe and the United States. Not only did he contribute to instrument design from the 1930's on, he was one of the principle engineers in establishing the classic tape music studios in Europe. His contributions straddled the two major design traditions of new sounds versus imitation of traditional ones without much bias since he was primarily an engineer interested in providing tools for a wide range of musicians. Other instruments which he subsequently built included the Melodium, the MELOCHORD and the Polychord (Bode's other contributions will be discussed later in this essay).

By the late 1930's there was an increase of experimental activity in both Europe and the United States. 1938 saw the installation of the ANS Synthesizer at the Moscow Experimental Music Studio. JOHN CAGE began his long fascination with electronic sound sources in 1939 with the presentation of *Imaginary Landscape No. 1*, a live performance work whose score includes a part for disc recordings performed on a variable speed phonograph. A number of similar works utilizing recorded sound and electronic sound sources followed. Cage had also been one of the most active proselytizers for electronic music through his writings, as were Edgard Varèse, Joseph Schillinger, Leopold Stokowski, Henry Cowell, Carlos Chavez and PERCY GRAINGER. It was during the 1930's that Grainger seriously began to pursue the building of technological tools capable of realizing his radical concept of *FREE MUSIC* notated as spatial non-tempered structures on graph paper. He composed such a work for an ensemble of four Theremins (1937) and began to collaborate with Burnett Cross to design a series of synchronized oscillator instruments controlled by a paper tape roll mechanism. These instruments saw a number of incarnations until Grainger's death in 1961.

In 1939 Homer Dudley created the voder and the vocoder for non-musical applications associated with speech analysis. The VODER was a keyboard-operated encoding instrument consisting of bandpass channels for the simulation of resonances in the human voice. It also contained tone and noise sources for imitating vowels and consonants. The VOCODER was the corresponding decoder which consisted of an analyzer and synthesizer for analyzing and then reconstituting the same speech. Besides being one of the first sound modification devices, the vocoder was to take on an important role in electronic music as a voice processing device that is still widely in use today.

The important technical achievements of the 1930's included the first successful television transmission and major innovations in audio recording. Since the turn of the century, research into improving upon the magnetic wire recorder, invented by VALDEMAR POULSEN, had steadily progressed. A variety of improvements had been made, most notably the use of electrical



amplification and the invention of the Alternating Current bias technique. The next major improvement was the replacement of wire with steel bands, a fairly successful technology that played a significant role in the secret police of the Nazi party. The German scientist Fritz Pfeumer had begun to experiment with oxide-coated paper and plastic tape as early as 1927 and the I.G. Farbenindustrie introduced the first practical plastic recording tape in 1932. The most successful of the early magnetic recording devices was undoubtedly the AEG Magnetophone introduced in 1935 at the Berlin Radio Fair. This device was to become the prototypical magnetic tape recorder and was vastly superior to the wire recorders then in use. By 1945 the Magnetophone adopted oxide-coated paper tape. After World War II the patents for this technology were transferred to the United States as war booty and further improvements in tape technology progressed there. Widespread commercial manufacturing and distribution of magnetic tape recorders became a reality by 1950.

The influence of World War II upon the arts was obviously drastic. Most experimental creative activity ceased and technical innovation was almost exclusively dominated by military needs. European music was the most seriously affected with electronic music research remaining dormant until the late 1940's. However, with magnetic tape recording technology now a reality, a new period of rapid innovation took place. At the center of this new activity was the ascendancy of the tape music studio as both compositional tool and research institution. Tape recording revolutionized electronic music more than any other single event in that it provided a flexible means to both store and manipulate sound events. The result was the defining of electronic music as a true genre. While the history of this genre before 1950 has primarily focused upon instrument designers, after 1950 the emphasis shifts towards the composers who consolidated the technical gains of the first half of the 20th century.

Just prior to the event of the tape recorder, PIERRE SCHAEFFER had begun his experiments with manipulation of phonograph recordings and quickly evolved a theoretical position which he named *Musique Concrète* in order to emphasize the sculptural aspect of how the sounds were manipulated. Schaeffer predominantly used sounds of the environment that had been recorded through microphones onto disc and later tape. These "sound objects" were then manipulated as pieces of sound that could be spliced into new time relationships, processed through a variety of devices, transposed to different frequency registers through tape speed variations, and ultimately combined into a montage of various mixtures of sounds back onto tape. In 1948 Schaeffer was joined by the engineer Jacques Poullin who subsequently played a significant role in the technical evolution of tape music in France. That same year saw the initial broadcast



of Musique Concrète over French Radio and was billed as a 'concert de bruits'. The composer PIERRE HENRY then joined Schaeffer and Poullin in 1949. Together they constructed the *SYMPHONIE POUR UN HOMME SEUL*, one of the true classics of the genre completed before they had access to tape recorders.

By 1950 Schaeffer and Henry were working with magnetic tape and the evolution of musique concrète proceeded at a fast pace. The first public performance was given in that same year at the École Normale de Musique. In the following year, French National Radio installed a sophisticated studio for the *Group for Research on Musique Concrète*. Over the next few years significant composers began to be attracted to the studio including Pierre Boulez, Michel Philippot, Jean Barraqué, Phillipe Arthuys, EDGARD VARÈSE, and OLIVIER MESSIAEN. In 1954 Varèse composed the tape part to *DÉSERTS* for orchestra and tape at the studio and the work saw its infamous premiere in December of that year.

Since Musique Concrète was both a musical and aesthetic research project, a variety of theoretical writings emerged to articulate the movement's progress. Of principal importance was Schaeffer's book *A la recherche d'une musique concrète*. In it he describes the group's experiments in a pseudo-scientific manner that forms a lexicon of sounds and their distinctive characteristics which should determine compositional criteria and organization. In collaboration with A. Moles, Schaeffer specified a classification system for acoustical material according to orders of magnitude and other criteria. In many ways these efforts set the direction for the positivist philosophical bias that has dominated the "research" emphasis of electronic music institutions in France and elsewhere.

The sonic and musical characteristics of early musique concrète were pejoratively described by Olivier Messiaen as containing a high level of surrealistic agony and literary descriptivism. The movement's evolution saw most of the participating composers including Schaeffer move away from the extreme dislocations of sound and distortion associated with its early compositions and simple techniques. Underlying the early works was a fairly consistent philosophy best exemplified by a statement by Schaeffer:

*"I belong to a generation which is largely torn by dualisms. The catechism taught to men who are now middle-aged was a traditional one, traditionally absurd: spirit is opposed to matter, poetry to technique, progress to tradition, individual to the group and how much else. From all this it takes just one more step to conclude that the world is absurd, full of unbearable contradictions. Thus a violent desire to deny, to destroy one of the concepts, especially in the realm of form, where, according to Malraux, the Absolute is coined. Fashion faintheartedly approved this nihilism.*



*If musique concrète were to contribute to this movement, if, hastily adopted, stupidly understood, it had only to add its additional bellowing, its new negation, after so much smearing of the lines, denial of golden rules (such as that of the scale), I should consider myself rather unwelcome. I have the right to justify my demand, and the duty to lead possible successors to this intellectually honest work, to the extent to which I have helped to discover a new way to create sound, and the means—as yet approximate—to give it form.*

*... Photography, whether the fact be denied or admitted, has completely upset painting, just as the recording of sound is about to upset music .... For all that, traditional music is not denied; any more than the theatre is supplanted by the cinema. Something new is added: a new art of sound. Am I wrong in still calling it music?"*

While the tape studio is still a major technical and creative force in electronic music, its early history marks a specific period of technical and stylistic activity. As recording technology began to reveal itself to composers, many of whom had been anxiously awaiting such a breakthrough, some composers began to work under the auspices of broadcast radio stations and recording studios with professional tape recorders and test equipment in off hours. Others began to scrounge and share equipment wherever possible, forming informal cooperatives based upon available technology. While Schaeffer was defining *musique concrète*, other independent composers were experimenting with tape and electronic sound sources. The end of 1940's saw French composer Paul Boisselet compose some of the earliest live performance works for instruments, tape recorders and electronic oscillators. In the United States, Bebe and Louis Barron began their pioneering experiments with tape collage. As early as 1948 the Canadian composer/engineer Hugh Le Caine was hired by the National Research Council of Canada to begin building electronic musical instruments.

In parallel to all of these events, another major lineage of tape studio activity began to emerge in Germany. According to the German physicist Werner Meyer-Eppler the events comprising the German electronic music history during this time are as follows. In 1948 the inventor of the Vocoder, Homer Dudley, demonstrated for Meyer-Eppler his device. Meyer-Eppler subsequently used a tape recording of the Vocoder to illustrate a lecture he gave in 1949 called *Developmental Possibilities of Sound*. In the audience was the aforementioned Robert Beyer, now employed at the Northwest German Radio, Cologne. Beyer must have been profoundly impressed by the presentation since it was decided that lectures should be formulated on the topic of "electronic music" for the International Summer School for New Music in



Darmstadt the following year. Much of the subsequent lecture by Meyer-Eppler contained material from his classic book, *Electronic Tone Generation, Electronic Music, and Synthetic Speech*.

By 1951 Meyer-Eppler began a series of experiments with synthetically generated sounds using Harald Bode's Melochord and an AEG magnetic tape recorder. Together with Robert Beyer and Herbert Eimert, Meyer-Eppler presented his research as a radio program called "The World of Sound of Electronic Music" over German Radio, Cologne. This broadcast helped to convince officials and technicians of the Cologne radio station to sponsor an official studio for electronic music. From its beginning the COLOGNE STUDIO differentiated itself from the Musique Concrète activities in Paris by limiting itself to "pure" electronic sound sources that could be manipulated through precise compositional techniques derived from Serialism.

While one of the earliest compositional outcomes from the influence of Meyer-Eppler was Bruno Maderna's collaboration with him entitled *Musica su due Dimensioni* for flute, percussion, and loudspeaker, most of the other works that followed were strictly concerned with utilizing only electronic sounds such as pure sine-waves. One of the first attempts at creating this labor intensive form of studio based additive synthesis was KARLHEINZ STOCKHAUSEN who created his *Étude* out of pure sine-waves at the Paris studio in 1952. Similar works were produced at the Cologne facilities by Beyer and Eimert at about this time and subsequently followed by the more sophisticated attempts by Stockhausen, *Studie I* (1953) and *STUDIE II* (1954). In 1954 a public concert was presented by Cologne radio that included works by Stockhausen, Goeyvaerts, Pousseur, Gredinger, and Eimert. Soon other composers began working at the Cologne studio including Koenig, Heiss, Klebe, KAGEL, LIGETI, BRÜN and ERNST KRENEK. The later composer completed his *Spiritus Intelligentiae Sanctus* at the Cologne studio in 1956. This work along with Stockhausen's *GESANG DER JÜNGLINGE*, composed at the same time, signify the end of the short-lived pure electronic emphasis claimed by the Cologne school. Both works used electronically-generated sounds in combination with techniques and sound sources associated with musique concrète.

While the distinction usually posited between the early Paris and Cologne schools of tape music composition emphasizes either the nature of the sound sources or the presence of an organizational bias such as Serialism, I tend to view this distinction more in terms of a reorganization at mid-century of the representationist versus modernist dialect which appeared in prior decades. Even though Schaeffer and his colleagues were consciously aligned in overt ways with the Futurists concern with noise, they tended to rely on dramatic expression that was dependent upon illusionistic associations to the sounds undergoing deconstruction.

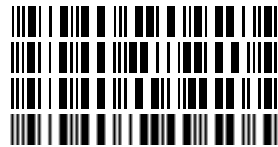

The early Cologne school appears to have been concerned with an authentic and didactic display of the electronic material and its primary codes as if it were possible to reveal the metaphysical and intrinsic nature of the material as a new perceptual resource. Obviously the technical limitations of the studio at that time, in addition to the aesthetic demands imposed by the current issues of musicality, made their initial pursuit too problematic.

Concurrent with the tape studio developments in France and Germany there were significant advances occurring in the United States. While there was not yet any significant institutional support for the experimental work being pursued by independent composers, some informal projects began to emerge. The Music for Magnetic Tape Project was formed in 1951 by JOHN CAGE, Earle Brown, Christian Wolff, David Tudor, and Morton Feldman and lasted until 1954. Since the group had no permanent facility, they relied on borrowed time in commercial sound studios such as that maintained by Bebe and Louis Barron or used borrowed equipment that they could share. The most important work to have emerged from this collective was Cage's *WILLIAM'S MIX*. The composition used hundreds of prerecorded sounds from the Barron's library as the source from which to fulfill the demands of a meticulously notated score that specified not only the categories of sounds to be used at any particular time but also how the sounds were to be spliced and edited. The work required over nine months of intensive labor on the part of Cage, Brown and Tudor to assemble. While the final work may not have sounded to untutored ears as very distinct from the other tape works produced in France or Cologne at the same time, it nevertheless represented a radical compositional and philosophical challenge to these other schools of thought.

In the same year as Cage's *William's Mix*, VLADIMIR USSACHEVSKY gave a public demonstration of his tape music experiments at Columbia University. Working in almost complete isolation from the other experimenters in Europe and the United States, Ussachevsky began to explore tape manipulation of electronic and instrumental sounds with very limited resources. He was soon joined by OTTO LUENING and the two began to compose in earnest some of the first tape compositions in the United States at the home of Henry Cowell in Woodstock, New York: *Fantasy in Space*, *Low Speed*, and *Sonic Contours*. The works, after completion in Ussachevsky's living room in New York and in the basement studio of Arturo Toscanini's Riverdale home, were presented at the Museum of Modern Art in October of 1952.

Throughout the 1950's important work in electronic music experimentation only accelerated at a rapid pace. In 1953 an Italian electronic music studio (Studio de Fonologia) was established at the Radio Audizioni Italiane in Milan. During its early years the studio attracted many important international figures



including LUCIANO BERIO, Niccolo Castiglioni, Aldo Clementi, Bruno Maderna, LUIGINONO, John Cage, Henri Pousseur, André Boucourechliev, and Bengt Hambraeus. Studios were also established at the Philips research labs in Eindhoven and at NHK (Japanese Broadcasting System) in 1955. In that same year the David Sarnoff Laboratories of RCA in Princeton, New Jersey introduced the OLSON-BELAR SOUND SYNTHESIZER to the public. As its name states, this instrument is generally considered the first modern "synthesizer" and was built with the specific intention of synthesizing traditional instrumental timbres for the manufacture of popular music. In an interesting reversal of the usual industrial absorption of artistic innovation, the machine proved inappropriate for its original intent and was later used entirely for electronic music experimentation and composition. Since the device was based upon a combination of additive and subtractive synthesis strategies, with a control system consisting of a punched paper roll or tab-card programming scheme, it was an extremely sophisticated instrument for its time. Not only could a composer generate, combine and filter sounds from the machine's tuning-fork oscillators and white-noise generators, sounds could be input from a microphone for modification. Ultimately the device's design philosophy favored fairly classical concepts of musical structure such as precise control of twelve-tone pitch material and was therefore favored by composers working within the serial genre.

The first composers to work with the Olson-Belar Sound Synthesizer (later known as the RCA Music Synthesizer) were VLADIMIR USSACHEVSKY, OTTO LEUNING and MILTON BABBITT who managed to initially gain access to it at the RCA Labs. Within a few years this trio of composers in addition to Roger Sessions managed to acquire the device on a permanent basis for the newly established Columbia-Princeton Electronic Music Center in New York City. Because of its advanced facilities and policy of encouragement to contemporary composers, the center attracted a large number of international figures such as ALICE SHIELDS, PRIL SMILEY, Michiko Toyama, Bülent Arel, Mario Davidovsky, Halim El-Dabh, Mel Powell, Jacob Druckman, Charles Wourinen, and Edgard Varèse.

In 1958 the University of Illinois at Champaign/Urbana established the Studio for Experimental Music. Under the initial direction of LEJAREN HILLER the studio became one of the most important centers for electronic music research in the United States. Two years earlier, Hiller, who was also a professional chemist, applied his scientific knowledge of digital computers to the composition of the *ILLIAC SUITE FOR STRING QUARTET*, one of the first attempts at serious computer-aided musical composition. In subsequent years the resident faculty connected with the Studio for Experimental Music included composers HERBERT

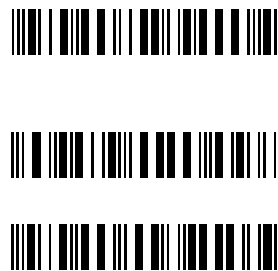
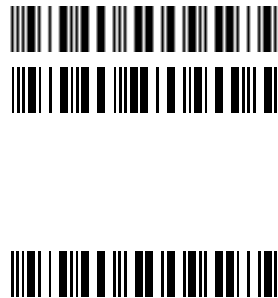
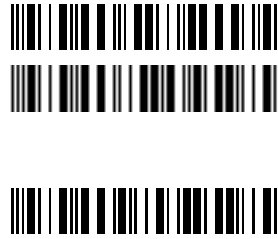

BRÜN, KENNETH GABURO, and SALVATORE MARTIRANO along with the engineer James Beauchamp whose Harmonic Tone Generator was one of the most interesting special sound generating instruments of the period.

By the end of the decade PIERRE SCHAEFFER had reorganized the Paris studio into the Groupe de Recherches de Musicales and had abandoned the term *musique concrète*. His staff was joined at this time by LUC FERRARI and François-Bernard Mache, and later by François Bayle and Bernard Parmegiani. The Greek composer, architect and mathematician YANNIS XENAKIS was also working at the Paris facility as was LUCIANO BERIO. Xenakis produced his classic composition *DIAMORPHOSES* in 1957 in which he formulated a theory of density change which introduced a new category of sounds and structure into *musique concrète*.

In addition to the major technical developments and burgeoning studios just outlined there was also a dramatic increase in the actual composition of substantial works. From 1950 to 1960 the vocabulary of tape music shifted from the fairly pure experimental works which characterized the classic Paris and Cologne schools to more complex and expressive works which explored a wide range of compositional styles. More and more works began to appear by the mid-1950's which addressed the concept of combining taped sounds with live instruments and voices. There was also a tentative interest, and a few attempts, at incorporating taped electronic sounds into theatrical works. While the range of issues being explored was extremely broad, much of the work in the various tape studios was an extension of the Serialism which dominated instrumental music. By the end of the decade new structural concepts began to emerge from working with the new electronic sound sources that influenced instrumental music. This expansion of timbral and organizational resources brought strict Serialism into question.

In order to summarize the activity of the classic tape studio period a brief survey of some of the major works of the 1950's is called for. This list is not intended to be exhaustive but only to provide a few points of reference:

1949) Schaeffer and Henry: *SYMPHONIE POUR UN HOMME SEUL*

1951) Grainger: *FREE MUSIC*

1952) Maderna: *Musica su due Dimensioni*; Cage: *William's Mix*; Leuning: *Fantasy in Space*; Ussachevsky: *Sonic Contours*; Brau: *Concerto de Janvier*

1953) Schaeffer and Henry: *ORPHÉE*; Stockhausen: *Studie I*

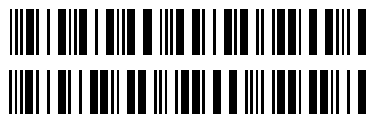
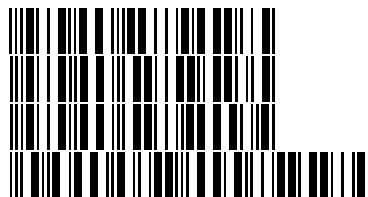
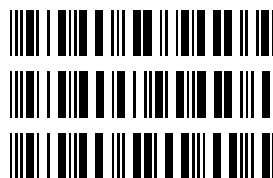

1954) Varèse: *DÉSERTS*; Stockhausen: *Studie II*; Leuning and Ussachevsky: *A Poem in Cycles and Bells*



1955) B. & L. Barron: soundtrack to *Forbidden Planet*

1956) Krenek: *Spiritus Intelligentiae Sanctus*; Stockhausen: *GESANG DER JÜNGLINGE*; Berio: *Mutazioni*; Maderna: *Notturmo*; Hiller: *ILLIAC SUITE FOR STRING QUARTET*



1957) Xenakis: *DIAMORPHOSES*; Pousseur: *Scambi*; Badings: *Evolutionen*



1958) Varèse: *POÈME ÉLECTRONIQUE*; Ligeti: *ARTIKULATION*; Kagel: *Transición I*; Cage: *FONTANA MIX*; Berio: *THEMA—OMAGGIO A JOYCE*; Xenakis: *Concret P-H II*; Pousseur: *RIMES POUR DIFFÉRENTES SOURCES SONORES*

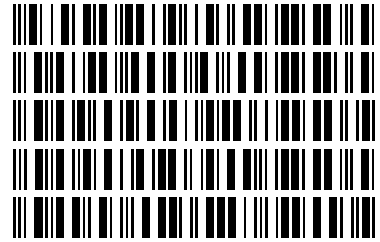

1959) Kagel: *Transición II*; Cage: *INDETERMINACY*



1960) Berio: *Differences*; Gerhard: *Collages*; Maxfield: *NIGHT MUSIC*; Ashley: *The Fourth of July*; Takemitsu: *Water Music*; Xenakis: *Orient-Occident III*



By 1960 the evolution of the tape studio was progressing dramatically. In Europe the institutional support only increased and saw a mutual interest arise from both the broadcast centers and from academia. For instance it was in 1960 that the electronic music studio at the Philips research labs was transferred to the INSTITUTE OF SONOLOGY at the University of Utrecht. While in the United States it was always the universities that established serious electronic music facilities, that situation was problematic for certain composers who resisted the institutional milieu. Composers such as Gordon MUMMA and ROBERT ASHLEY had been working independently with tape music since 1956 by gathering together their own technical resources. Other composers who were interested in using electronics found that the tape medium was unsuited to their ideas. JOHN CAGE, for instance, came to reject the whole aesthetic that accompanied tape composition as incompatible with his philosophy of indeterminacy and live performance. Some composers began to seek out other technical solutions in order to specify more precise compositional control than the tape studio could provide them. It was into this climate of shifting needs that a variety of new electronic devices emerged.



The coming of the 1960's saw a gradual cultural revolution

which was co-synchronous with a distinct acceleration of new media technologies. While the invention of the transistor in 1948 at Bell Laboratories had begun to impact electronic manufacturing, it was during the early 1960's that major advances in electronic design took shape. The subsequent innovations and their impact upon electronic music were multifold and any understanding of them must be couched in separate categories for the sake of convenience. The categories to be delineated are 1) the emergence of the voltage-controlled analog synthesizer; 2) the evolution of computer music; 3) live electronic performance practice; and 4) the explosion of multi-media. However, it is important that the reader appreciate that the technical categories under discussion were never exclusive but in fact interpenetrated freely in the compositional and performance styles of musicians. It is also necessary to point out that any characterization of one form of technical means as superior to another (i.e. computers versus synthesizers) is not intentional. It is the author's contention that the very nature of the symbiosis between machine and artist is such that each instrument, studio facility, or computer program yields its own working method and unique artistic produce. Preferences between technological resources emerge from a match between a certain machine and the imaginative intent of an artist, and not from qualities that are hierarchically germane to the history of technological innovation. Claims for technological efficiency may be relevant to a very limited context but are ultimately absurd when viewed from a broader perspective of actual creative achievement.

## 1) THE VOLTAGE - CONTROLLED ANALOG SYNTHESIZER

**A definition:** Unfortunately the term "synthesizer" is a gross misnomer. Since there is nothing synthetic about the sounds generated from this class of analog electronic instruments, and since they do not "synthesize" other sounds, the term is more the result of a conceptual confusion emanating from industrial nonsense about how these instruments "imitate" traditional acoustic ones. However, since the term has stuck, becoming progressively more ingrained over the years, I will use the term for the sake of convenience. In reality the analog voltage-controlled synthesizer is a collection of waveform and noise generators, modifiers (such as filters, ring modulators, amplifiers), mixers and control devices packaged in modular or integrated form. The generators produce an electronic signal which can be patched through the modifiers and into a mixer or amplifier where it is made audible through loudspeakers. This sequence of interconnections constitutes a signal path which is determined by means

of patch cords, switches, or matrix pinboards. Changes in the behaviors of the devices (such as pitch or loudness) along the signal path are controlled from other devices which produce control voltages. These control voltage sources can be a keyboard, a ribbon controller, a random voltage source, an envelope generator or any other compatible voltage source.

The story of the analog "synthesizer" has no single beginning. In fact, its genesis is an excellent example of how a good idea often emerges simultaneously in different geographic locations to fulfill a generalized need. In this case the need was to consolidate the various electronic sound generators, modifiers and control devices distributed in fairly bulky form throughout the classic tape studio. The reason for doing this was quite straight forward: to provide a personal electronic system to individual composers that was specifically designed for music composition and/or live performance, and which had the approximate technical capability of the classic tape studio at a lower cost. The geographic locales where this simultaneously occurred were the east coast of the United States, San Francisco, Rome and Australia.

The concept of modularity usually associated with the analog synthesizer must be credited to Harald Bode who in 1960 completed the construction of his MODULAR SOUND MODIFICATION SYSTEM. In many ways this device predicted the more concise and powerful modular synthesizers that began to be designed in the early 1960's and consisted of a ring modulator, envelope follower, tone-burst-responsive envelope generator, voltage-controlled amplifier, filters, mixers, pitch extractor, comparator and frequency divider, and a tape loop repeater. This device may have had some indirect influence on Robert Moog but the idea for his modular synthesizer appears to have evolved from another set of circumstances.

In 1963, MOOG was selling transistorized Theremins in kit form from his home in Ithaca, New York. Early in 1964 the composer Herbert Deutsch was using one of these instruments and the two began to discuss the application of solid-state technology to the design of new instruments and systems. These discussions led Moog to complete his first prototype of a modular electronic music synthesizer later that year. By 1966 the first production model was available from the new company he had formed to produce this instrument. The first systems which Moog produced were principally designed for studio applications and were generally large modular assemblages that contained voltage-controlled oscillators, filters, voltage-controlled amplifiers, envelope generators, and a traditional style keyboard for voltage-control of the other modules. Interconnection between the modules was achieved through patch cords. By 1969 Moog saw the necessity for a smaller portable instrument and began to manufacture the Mini Moog, a concise version of the studio system that





contained an oscillator bank, filter, mixer, VCA and keyboard. As an instrument designer Moog was always a practical engineer. His basically commercial but egalitarian philosophy is best exemplified by some of the advertising copy which accompanied the Mini Moog in 1969 and resulted in its becoming the most widely used synthesizer in the "music industry":

*"R.A. Moog, Inc. built its first synthesizer components in 1964. At that time, the electronic music synthesizer was a cumbersome laboratory curiosity, virtually unknown to the listening public. Today, the Moog synthesizer has proven its indispensability through its widespread acceptance. Moog synthesizers are in use in hundreds of studios maintained by universities, recording companies, and private composers throughout the world. Dozens of successful recordings, film scores, and concert pieces have been realized on Moog synthesizers. The basic synthesizer concept as developed by R.A. Moog, Inc., as well as a large number of technological innovations, have literally revolutionized the contemporary musical scene, and have been instrumental in bringing electronic music into the mainstream of popular listening.*

*In designing the Mini Moog, R. A. Moog engineers talked with hundreds of musicians to find out what they wanted in a performance synthesizer. Many prototypes were built over the past two years, and tried out by musicians in actual live-performance situations. Mini Moog circuitry is a combination of our time-proven and reliable designs with the latest developments in technology and electronic components.*

*The result is an instrument which is applicable to studio composition as much as to live performance, to elementary and high school music education as much as to university instruction, to the demands of commercial music as much as to the needs of the experimental avant garde. The Mini Moog offers a truly unique combination of versatility, playability, convenience, and reliability at an eminently reasonable price."*

In contrast to Moog's industrial stance, the rather counter-cultural design philosophy of DONALD BUCHLA and his voltage-controlled synthesizers can partially be attributed to the geographic locale and cultural circumstances of their genesis. In 1961 San Francisco was beginning to emerge as a major cultural center with several vanguard composers organizing concerts and other performance events. MORTON SUBOTNICK was starting his career in electronic music experimentation, as were PAULINE OLIVEROS, Ramon Sender and TERRY RILEY. A primitive studio had been started at the San Francisco Conservatory of Music by Sender where he and Oliveros had begun a series of experimental



music concerts. In 1962 this equipment and other resources from electronic surplus sources were pooled together by Sender and Subotnick to form the San Francisco Tape Music Center which was later moved to Mills College in 1966. Because of the severe limitations of the equipment, Subotnick and Sender sought out the help of a competent engineer in 1962 to realize a design they had concocted for an optically based sound generating instrument. After a few failures at hiring an engineer they met DONALD BUCHLA who realized their design but subsequently convinced them that this was the wrong approach for solving their equipment needs. Their subsequent discussions resulted in the concept of a modular system. Subotnick describes their idea in the following terms:



*“Our idea was to build the black box that would be a palette for composers in their homes. It would be their studio. The idea was to design it so that it was like an analog computer. It was not a musical instrument but it was modular...It was a collection of modules of voltage-controlled envelope generators and it had sequencers in it right off the bat...It was a collection of modules that you would put together. There were no two systems the same until CBS bought it...Our goal was that it should be under \$400 for the entire instrument and we came very close. That’s why the original instrument I fundraised for was under \$500.”*

Buchla’s design approach differed markedly from Moog. Right from the start Buchla rejected the idea of a “synthesizer” and has resisted the word ever since. He never wanted to “synthesize” familiar sounds but rather emphasized new timbral possibilities. He stressed the complexity that could arise out of randomness and was intrigued with the design of new control devices other than the standard keyboard. He summarizes his philosophy and distinguishes it from Moog’s in the following statement:



*“I would say that philosophically the prime difference in our approaches was that I separated sound and structure and he didn’t. Control voltages were interchangeable with audio. The advantage of that is that he required only one kind of connector and that modules could serve more than one purpose. There were several drawbacks to that kind of general approach, one of them being that a module designed to work in the structural domain at the same time as the audio domain has to make compromises. DC offset doesn’t make any difference in the sound domain but it makes a big difference in the structural domain, whereas harmonic distortion makes very little difference in the control area but it can be very significant in the audio areas. You also have a matter of just being able to discern what’s happening in a system by looking at it. If you have a very complex patch, it’s nice to be able to tell what*

*aspect of the patch is the structural part of the music versus what is the signal path and so on. There's a big difference in whether you deal with linear versus exponential functions at the control level and that was a very inhibiting factor in Moog's more general approach.*

*Uncertainty is the basis for a lot of my work. One always operates somewhere between the totally predictable and the totally unpredictable and to me the "source of uncertainty," as we called it, was a way of aiding the composer. The predictabilities could be highly defined or you could have a sequence of totally random numbers. We had voltage control of the randomness and of the rate of change so that you could randomize the rate of change. In this way you could make patterns that were of more interest than patterns that are totally random."*

While the early Buchla instruments contained many of the same modular functions as the Moog, it also contained a number of unique devices such as its random control voltage sources, sequencers and voltage-controlled spatial panners. Buchla has maintained his unique design philosophy over the intervening years producing a series of highly advanced instruments often incorporating hybrid digital circuitry and unique control interfaces.

The other major voltage-controlled synthesizers to arise at this time (1964) were the Synket, a highly portable instrument built by Paul Ketoff, and a unique machine designed by Tony Furse in Australia. According to composer Joel Chadabe, the SYNKET resulted from discussions between himself, Otto Leuning and JOHN EATON while these composers were in residence in Rome.



Don Buchla in his Berkeley, California studio with several of his creations, late 1970's. Courtesy of Don Buchla.

Chadabe had recently inspected the developmental work of Robert Moog and conveyed this to Eaton and Leuning. The engineer Paul Ketoff was enlisted to build a performance oriented instrument for Eaton who subsequently became the virtuoso on this small synthesizer, using it extensively in subsequent years. The machine built by Furse was the initial foray into electronic instrument design by this brilliant Australian engineer. He later became the principal figure in the design of some of the earliest and most sophisticated digital synthesizers of the 1970's.

After these initial efforts a number of other American designers and manufacturers followed the lead of Buchla and Moog. One of the most successful was the ARP SYNTHESIZER built by Tonus, Inc. with design innovations by the team of Dennis Colin and David Friend. The studio version of the ARP was introduced in 1970 and basically imitated modular features of the Moog and Buchla instruments. A year later they introduced a smaller portable version which included a preset patching scheme that simplified the instrument's function for the average pop-oriented performing musician. Other manufacturers included EML, makers of the ELECTRO-COMP, a small synthesizer oriented to the educational market; OBERHIEM, one of the earliest polyphonic synthesizers; muSonics' SONIC V SYNTHESIZER; PAIA, makers of a synthesizer in kit form; Roland; Korg; and the highly sophisticated line of modular analog synthesizer systems designed and manufactured by Serge Tcherepnin and referred to as Serge Modular Music Systems.

In Europe the major manufacturer was undoubtedly EMS, a British company founded by its chief designer Peter Zinovieff. EMS built the Synthi 100, a large integrated system which introduced a matrix-pinboard patching system, and a small portable synthesizer based on similar design principles initially called the Putney but later modified into the SYNTHI A or Portabella. This later instrument became very popular with a number of composers who used it in live performance situations.

One of the more interesting footnotes to this history of the analog synthesizer is the rather problematic relationship that many of the designers have had with commercialization and the subsequent solution of manufacturing problems. While the commercial potential for these instruments became evident very early on in the 1960's, the different aesthetic and design philosophies of the engineers demanded that they deal with this realization in different ways. Buchla, who early on got burnt by larger corporate interests, has dealt with the burden of marketing by essentially remaining a cottage industry, assembling and marketing his instruments from his home in Berkeley, California. In the case of MOOG, who as a fairly competent businessman grew a small business in his home into a distinctly commercial endeavor, even he ultimately left Moog Music in 1977, after the company had

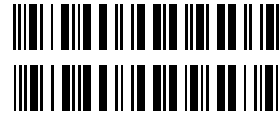
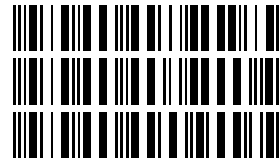

been acquired by two larger corporations, to pursue his own design interests.

It is important to remember that the advent of the analog voltage-controlled synthesizer occurred within the context of the continued development of the tape studio which now included the synthesizer as an essential part of its new identity as the electronic music studio. It was estimated in 1968 that 556 non-private electronic music studios had been established in 39 countries. An estimated 5,140 compositions existed in the medium by that time.

Some of the landmark voltage-controlled "synthesizer" compositions of the 1960's include works created with the "manufactured" machines of Buchla and Moog but other devices were certainly also used extensively. Most of these works were tape compositions that used the synthesizer as resource. The following list includes a few of the representative tape compositions and works for tape with live performers made during the 1960's with synthesizers and other sound sources.

1960) Stockhausen: *KONTAKTE*; Mache: *Volumes*;

1961) Berio: *VISAGE*; Dockstader: *TWO FRAGMENTS FROM APOCALYPSE*

1962) Xenakis: *BOHOR I*; Philippot: *Étude III*; Parmegiani: *DANSE*;

1963) Bayle: *PORTRAITS DE L'OISEAU-QUI-N'EXISTE-PAS*; Nordheim: *EPITAFFIO*

1964) Babbitt: *Ensembles for Synthesizer*; Brün: *Futility*; Nono: *LA FABBRICA ILLUMINATA*

1965) Gaburo: *LEMON DROPS*, Mimaroglu: *Agony*; Davidovsky: *Synchronisms No. 3*;

1966) Oliveros: *I OF IV*; Druckman: *Animus I*;

1967) Subotnick: *SILVER APPLES OF THE MOON*; Eaton: *CONCERTPIECE FOR SYN-KET AND SYMPHONY ORCHESTRA*; Koenig: *Terminus X*; Smiley: *ECLIPSE*;

1968) Carlos: *Switched-On Bach*; Gaburo: *DANTE'S JOYNTE*; Nono: *CONTRAPPUNTO DIALETTICO ALLA MENTE*

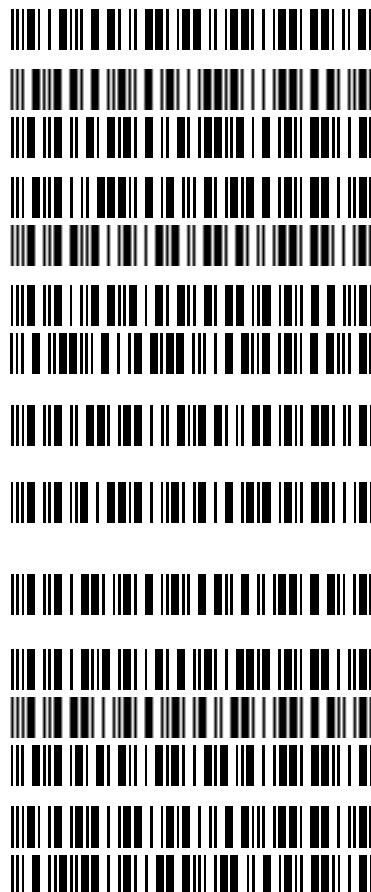

1969) Wuorinen: *TIME'S ENCOMIUM*; Ferrari: *MUSIC PROMENADE*

1970) Arel: *Stereo Electronic Music No. 2*; Lucier: *I AM SITTING IN A ROOM*

## 2) COMPUTER MUSIC

**A distinction:** *Analog* refers to systems where a physical quantity is represented by an analogous physical quantity. The traditional audio recording chain demonstrates this quite well since each stage of translation throughout constitutes a physical system that is analogous to the previous one in the chain. The fluctuations of air molecules which constitute sound are translated into fluctuations of electrons by a microphone diaphragm. These electrons are then converted via a bias current of a tape recorder into patterns of magnetic particles on a piece of tape. Upon playback the process can be reversed resulting in these fluctuations of electrons being amplified into fluctuations of a loudspeaker cone in space. The final displacement of air molecules results in an analogous representation of the original sounds that were recorded. *Digital* refers to systems where a physical quantity is represented through a counting process. In digital computers this counting process consists of a two-digit binary coding of electrical on-off switching states. In computer music the resultant digital code represents the various parameters of sound and its organization.

As early as 1954, the composer YANNIS XENAKIS had used a computer to aid in calculating the velocity trajectories of glissandi for his orchestral composition *Metastasis*. Since his background included a strong mathematical education, this was a natural development in keeping with his formal interest in combining mathematics and music. The search that had begun earlier in the century for new sounds and organizing principles that could be mathematically rationalized had become a dominant issue by the mid-1950's. Serial composers like MILTON BABBIT had been dreaming of an appropriate machine to assist in complex compositional organization. While the RCA Music Synthesizer fulfilled much of this need for Babbitt, other composers desired even more machine-assisted control. LEJAREN HILLER, a former student of Babbitt, saw the compositional potential in the early generation of digital computers and generated the *Illiac Suite* for string quartet as a demonstration of this promise in 1956.

Xenakis continued to develop, in a much more sophisticated manner, his unique approach to computer-assisted instrumental composition. Between 1956 and 1962 he composed a number of works such as *Morisma-Amorisma* using the computer as a

mathematical aid for finalizing calculations that were applied to instrumental scores. Xenakis stated that his use of probabilistic theories and the IBM 7090 computer enabled him to advance "...a form of composition which is not the object in itself, but an idea in itself, that is to say, the beginnings of a family of compositions."

The early vision of why computers should be applied to music was elegantly expressed by the scientist Heinz Von Foerster:

*"Accepting the possibilities of extensions in sounds and scales, how do we determine the new rules of synchronism and succession?"*

*It is at this point, where the complexity of the problem appears to get out of hand, that computers come to our assistance, not merely as ancillary tools but as essential components in the complex process of generating auditory signals that fulfill a variety of new principles of a generalized aesthetics and are not confined to conventional methods of sound generation by a given set of musical instruments or scales nor to a given set of rules of synchronism and succession based upon these very instruments and scales. The search for those new principles, algorithms, and values is, of course, in itself symbolic for our times."*

The actual use of the computer to generate sound first occurred at Bell Labs where Max Mathews used a primitive digital to analog converter to demonstrate this possibility in 1957. Mathews became the central figure at Bell Labs in the technical evolution of computer generated sound research and compositional programming with computer over the next decade. In 1961 he was joined by the composer JAMES TENNEY who had recently graduated from the University of Illinois where he had worked with Hiller and Gaburo to finish a major theoretical thesis entitled *Meta ≠ Hodos* For Tenney, the Bell Lab residency was a significant opportunity to apply his advanced theoretical thinking (involving the application of theories from Gestalt Psychology to music and sound perception) into the compositional domain. From 1961 to 1964 he completed a series of works which include what are probably the first serious compositions using the MUSIC IV program of Max Mathews and Joan Miller and therefore the first serious compositions using computer-generated sounds: *Noise Study*, *Four Stochastic Studies*, *Dialogue*, *Stochastic String Quartet*, *Ergodos I*, *Ergodos II*, and *PHASES*.

In the following extraordinarily candid statement, Tenney describes his pioneering efforts at Bell Labs:

*"I arrived at the Bell Telephone Laboratories in September, 1961, with the following musical and intellectual baggage:*

*1. numerous instrumental compositions reflecting the influence of*



Webern and Varèse;

2. two tape-pieces, produced in the Electronic Music Laboratory at the University of Illinois - both employing familiar, 'concrete' sounds, modified in various ways;

3. a long paper ("Meta ≠ Hodos, A Phenomenology of 20th Century Music and an Approach to the Study of Form", June, 1961), in which a descriptive terminology and certain structural principles were developed, borrowing heavily from Gestalt psychology. The central point of the paper involves the **clang**, or primary aural Gestalt, and basic laws of perceptual organization of clangs, clang-elements, and sequences (a high-order Gestalt-unit consisting of several clangs).

4. A dissatisfaction with all the purely synthetic electronic music that I had heard up to that time, particularly with respect to **timbre**;

5. ideas stemming from my studies of acoustics, electronics and - especially - information theory, begun in Hiller's class at the University of Illinois; and finally

6. a growing interest in the work and ideas of John Cage.

I leave in March, 1964, with:

1. six tape-compositions of computer-generated sounds - of which all but the first were also composed by means of the computer, and several instrumental pieces whose composition involved the computer in one way or another;

2. a far better understanding of the physical basis of **timbre**, and a sense of having achieved a significant extension of the range of timbres possible by synthetic means;

3. a curious history of renunciations of one after another of the traditional attitudes about music, due primarily to gradually more thorough assimilation of the insights of John Cage.

In my two-and-a-half years here I have begun many more compositions than I have completed, asked more questions than I could find answers for, and perhaps failed more often than I have succeeded. But I think it could not have been much different. The medium is new and requires new ways of thinking and feeling. Two years are hardly enough to have become thoroughly acclimated to it, but the process has at least begun."

In 1965 the research at Bell Labs resulted in the successful reproduction of an instrumental timbre: a trumpet waveform was recorded and then converted into a numerical representation and when converted back into analog form was deemed virtually indistinguishable from its source. This accomplishment by Mathews, Miller and the French composer JEAN-CLAUDE RISSET marks the beginning of the recapitulation of the traditional representationist versus modernist dialectic in the new context of digital computing. When contrasted against Tenney's use of the computer to obtain entirely novel waveforms and structural complexities, the use of such immense technological resources to reproduce the sound of a trumpet, appeared to many composers to be





a gigantic exercise in misplaced concreteness. When seen in the subsequent historical light of the recent breakthroughs of digital recording and sampling technologies that can be traced back to this initial experiment, the original computing expense certainly appears to have been vindicated. However, the dialectic of representationism and modernism has only become more problematic in the intervening years.

The development of computer music has from its inception been so critically linked to advances in hardware and software that its practitioners have, until recently, constituted a distinct class of specialized enthusiasts within the larger context of electronic music. The challenge that early computers and computing environments presented to creative musical work was immense. In retrospect, the task of learning to program and pit one's musical intelligence against the machine constraints of those early days now takes on an almost heroic air. In fact, the development of computer music composition is definitely linked to the evolution of greater interface transparency such that the task of composition could be freed up from the other arduous tasks associated with programming. The first stage in this evolution was the design of specific music-oriented programs such as MUSIC IV. The 1960's saw gradual additions to these languages such as MUSIC IVB (a greatly expanded assembly language version by Godfrey Winham and Hubert S. Howe); MUSIC IVBF (a fortran version of MUSIC IVB); and MUSIC360 (a music program written for the IBM 360 computer by Barry Vercoe). The composer Charles Dodge wrote during this time about the intent of these music programs for sound synthesis:

*"It is through simulating the operations of an ideal electronic music studio with an unlimited amount of equipment that a digital computer synthesizes sound. The first computer sound synthesis program that was truly general purpose (i.e., one that could, in theory, produce any sound) was created at the Bell Telephone Laboratories in the late 1950's. A composer using such a program must typically provide: (1) Stored functions which will reside in the computer's memory representing waveforms to be used by the **unit generators** of the program. (2) "Instruments" of his own design which logically interconnect these **unit generators**. (**Unit generators** are subprograms that simulate all the sound generation, modification, and storage devices of the ideal electronic music studio.) The computer "instruments" **play** the notes of the composition. (3) **Notes** may correspond to the familiar "pitch in time" or, alternatively, may represent some convenient way of dividing the time continuum."*

By the end of the 1960's computer sound synthesis research saw a large number of new programs in operation at a variety of academic and private institutions. The demands of the medium

however were still quite tedious and, regardless of the increased sophistication in control, remained a tape medium as its final product. Some composers had taken the initial steps towards using the computer for realtime performance by linking the powerful control functions of the digital computer to the sound generators and modifiers of the analog synthesizer. We will deal with the specifics of this development in the next section. From its earliest days the use of the computer in music can be divided into two fairly distinct categories even though these categories have been blurred in some compositions: 1) those composers interested in using the computer predominantly as a compositional device to generate structural relationships that could not be imagined otherwise and 2) the use of the computer to generate new synthetic waveforms and timbres.

A few of the pioneering works of computer music from 1961 to 1971 are the following:

1961) Tenney: *Noise Study*

1962) Tenney: *Four Stochastic Studies*

1963) Tenney: *PHASES*

1964) Randall: *QUARTETS IN PAIRS*

1965) Randall: *MUDGETT*

1966) Randall: *Lyric Variations*

1967) Hiller: *Cosahedron*

1968) Brün: *INDEFRAUDIBLES*; Risset: *COMPUTER SUITE FROM LITTLE BOY*

1969) Dodge: *CHANGES*; Risset: *Mutations I*

1970) Dodge: *EARTH'S MAGNETIC FIELD*

1971) Chowning: *SABELITHE*

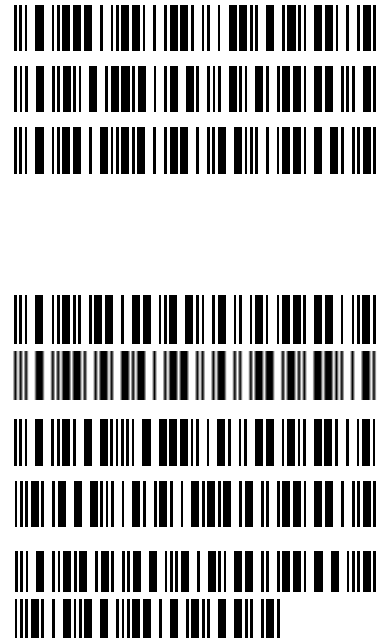

### 3) LIVE ELECTRONIC PERFORMANCE PRACTICE

**A Definition:** For the sake of convenience I will define live electronic music as that in which electronic sound generation, processing and control predominantly occurs in realtime during

a performance in front of an audience.

The idea that the concept of live performance with electronic sounds should have a special status may seem ludicrous to many readers. Obviously music has always been a performance art and the primary usage of electronic musical instruments before 1950 was almost always in a live performance situation. However, it must be remembered that the defining of electronic music as its own genre really came into being with the tape studios of the 1950's and that the beginnings of live electronic performance practice in the 1960's was in large part a reaction to both a growing dissatisfaction with the perceived sterility of tape music in performance (sound emanating from loudspeakers and little else) and the emergence of the various philosophical influences of chance, indeterminacy, improvisation and social experimentation.

The issue of combining tape with traditional acoustic instruments was a major one ever since Maderna, Varèse, Luening and Ussachevsky first introduced such works in the 1950's. A variety of composers continued to address this problem with increasing vigor into the 1960's. For many it was merely a means for expanding the timbral resources of the orchestral instruments they had been writing for, while for others it was a specific compositional concern that dealt with the expansion of structural aspects of performance in physical space. For instance MARIO DAVIDOVSKY and KENNETH GABURO have both written a series of compositions which address the complex contrapuntal dynamics between live performers and tape: Davidovsky's *Synchronisms 1-8* and Gaburo's *Antiphonies 1-11*. These works demand a wide variety of combinations of tape channels, instruments and voices in live performance contexts. In these and similar works by other composers the tape sounds are derived from all manner of sources and techniques including computer synthesis. The repertory for combinations of instruments and tape grew to immense international proportions during the 1960's and included works from Australia, North America, South America, Western Europe, Eastern Europe, Japan, and the Middle East. An example of how one composer viewed the dynamics of relationship between tape and performers is stated by Kenneth Gaburo:

*"On a fundamental level ANTIPHONY III is a **physical** interplay between live performers and two speaker systems (tape). In performance, 16 soloists are divided into 4 groups, with one soprano, alto, tenor, and bass in each. The groups are spatially separated from each other and from the speakers. Antiphonal aspects develop between and among the performers within each group, between and among groups, between the speakers, and between and among the groups and speakers.*

*On another level Antiphony III is an **auditory** interplay between tape and live bands. The tape band may be divided into 3 broad*



compositional classes: (1) quasi-duplication of live sounds, (2) electro-mechanical transforms of these beyond the capabilities of live performers, and (3) movement into complementary acoustic regions of synthesized electronic sound. Incidentally, I term the union of these classes **electronics**, as distinct from tape content which is pure concrete-mixing or electronic sound synthesis. The live band encompasses a broad spectrum from **normal singing** to vocal transmission having electronically associated characteristics. The total tape-live interplay, therefore, is the result of discrete mixtures of sound, all having the properties of the voice as a common point of departure.”

Another important aesthetic shift that occurred within the tape studio environment was the desire to compose onto tape using realtime processes that did not require subsequent editing. PAULINE OLIVEROS and Richard Maxfield were early practitioners of innovative techniques that allowed for live performance in the studio. Oliveros composed *I of IV* (1966) in this manner using tape delay and mixer feedback systems. Other composers discovered synthesizer patches that would allow for autonomous behaviors to emerge from the complex interactions of voltage-control devices. The output from these systems could be recorded as versions on tape or amplified in live performance with some performer modification. *Entropical Paradise* (1969) by Douglas Leedy is a classic example of such a composition for the Buchla Synthesizer.

The largest and most innovative category of live electronic music to come to fruition in the 1960's was the use of synthesizers and custom electronic circuitry to both generate sounds and process others, such as voice and/or instruments, in realtime performance. The most simplistic example of this application extends back to the very first use of electronic amplification by the early instruments of the 1930's. During the 1950's JOHN CAGE and DAVID TUDOR used microphones and amplification as compositional devices to emphasize the small sounds and resonances of the piano interior. In 1960 Cage extended this idea to the use of phonograph cartridges and contact microphones in *CARTRIDGE MUSIC*. The work focused upon the intentional amplification of small sounds revealed through an indeterminate process. Cage described the aural product: “*The sounds which result are noises, some complex, others extremely simple such as amplifier feedback, loud-speaker hum, etc. (All sounds, even those ordinarily thought to be undesirable, are accepted in this music.)*”

For Cage the abandonment of tape music and the move toward live electronic performance was an essential outgrowth of his philosophy of indeterminacy. Cage's aesthetic position necessitated the theatricality and unpredictability of live performance since he desired a circumstance where individual value judge-

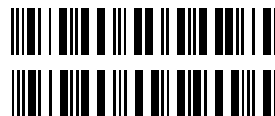
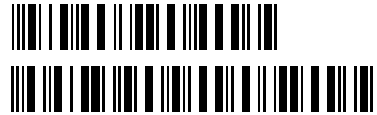

ments would not intrude upon the revelation and perception of new possibilities. Into the 1960's his fascination for electronic sounds in indeterminate circumstances continued to evolve and become inclusive of an ethical argument for the appropriateness of artists working with technology as critics and mirrors of their cultural environment. Cage composed a large number of such works during the 1960's often enlisting the inspired assistance of like-minded composer/performers such as David Tudor, Gordon Mumma, David Behrman, and Lowell Cross. Among the most famous of these works was the series of compositions entitled *VARIATIONS* of which there numbered eight by the end of the decade. These works were really highly complex and indeterminate happenings that often used a wide range of electronic techniques and sound sources.

The composer/performer DAVID TUDOR was the musician most closely associated with Cage during the 1960's. As a brilliant concert pianist during the 1950's he had championed the works of major avant-garde composers and then shifted his performance activities to electronics during the 1960's, performing other composer's live-electronic works and his own. His most famous composition, *RAINFOREST*, and its multifarious performances since it was conceived in 1968, almost constitute a musical sub-culture of electronic sound research. The work requires the fabrication of special resonating objects and sculptural constructs which serve as one-of-a-kind loudspeakers when transducers are attached to them. The constructed "loudspeakers" function to amplify and produce both additive and subtractive transformations of source sounds such as basic electronic waveforms. In more recent performances the sounds have included a wide selection of prerecorded materials.

While live electronic music in the 1960's was predominantly an American genre, activity in Europe and Japan also began to emerge. The foremost European composer to embrace live electronic techniques in performance was KARLHEINZ STOCKHAUSEN. By 1964 he was experimenting with the straightforward electronic filtering of an amplified tam-tam in *MICROPHONIE I*. Subsequent works for a variety of instrumental ensembles and/or voices, such as *Prozession* or *Stimmung*, explored very basic but ingenious use of amplification, filtering and ring modulation techniques in realtime performance. In a statement about the experimentation that led to these works Stockhausen conveys a clear sense of the spirit of exploration into sound itself that pervaded much of the live electronic work of the 1960's:

*"Last summer I made a few experiments by activating the tam-tam with the most disparate collection of materials I could find about the house —glass, metal, wood, rubber, synthetic materials— at the*



same time linking up a hand-held microphone (highly directional) to an electric filter and connecting the filter output to an amplifier unit whose output was audible through loudspeakers. Meanwhile my colleague Jaap Spek altered the settings of the filter and volume controls in an improvisatory way. At the same time we recorded the results on tape. This tape-recording of our first experiences in 'microphony' was a discovery of the greatest importance for me. We had come to no sort of agreement: I used such of the materials I had collected as I thought best and listened-in to the tam-tam surface with the microphone just as a doctor might listen-in to a body with his stethoscope; Spek reacted equally spontaneously to what he heard as the product of our joint activity."

In many ways the evolution of live electronic music parallels the increasing technological sophistication of its practitioners. In the early 1960's most of the works within this genre were concerned with fairly simple realtime processing of instrumental sounds and voices. Like Stockhausen's work from this period this may have been as basic as the manipulation of a live performer through audio filters, tape loops or the performer's interaction with acoustic feedback. ROBERT ASHLEY'S *Wolfman* (1964) is an example of the use of high amplification of voice to achieve feedback that alters the voice and a prerecorded tape.

By the end of the decade a number of composers had technologically progressed to designing their own custom circuitry. For example, GORDON MUMMA'S *MESA* (1966) and *HORNPIPE* (1967) are both examples of instrumental pieces that use custom-built electronics capable of semi-automatic response to the sounds generated by the performer or resonances of the performance space. One composer whose work illustrates a continuity of gradually increasing technical sophistication is DAVID BEHRMAN. From fairly rudimentary uses of electronic effects in the early 1960's his work progressed through various stages of live electronic complexification to compositions like *RUNTHROUGH* (1968), where custom-built circuitry and a photo electric sound distribution matrix is activated by performers with flashlights.

This trend toward new performance situations in which the technology functioned as structurally intrinsic to the composition continued to gain favor. Many composers began to experiment with a vast array of electronic control devices and unique sound sources which often required audio engineers and technicians to function as performing musicians, and musicians to be technically competent. Since the number of such works proliferated rapidly, a few examples of the range of activities during the 1960's must suffice. In 1965, ALVIN LUCIER presented his *Music for Solo Performer 1965* which used amplified brainwave signals to articulate the sympathetic resonances of an orchestra of percussion instruments. John Mizelle's *Photo Oscillations* (1969) used mul-

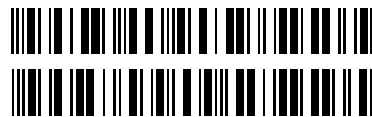

tiple lasers as light sources through which the performers walked in order to trigger a variety of photo-cell activated circuits. *Pendulum Music* (1968) by Steve Reich simply used microphones suspended over loudspeakers from long cables. The microphones were set in motion and allowed to generate patterns of feedback as they passed over the loudspeakers. For these works, and many others like them, the structural dictates which emerged out of the nature of the chosen technology also defined a particular composition as a unique environmental and theatrical experience.

Co-synchronous with the technical and aesthetic advances that were occurring in live performance that I have just outlined, the use of digital computers in live performance began to slowly emerge in the late 1960's. The most comprehensive achievement at marrying digital control sophistication to the realtime sound generation capabilities of the analog synthesizer was probably the *SAL-MAR CONSTRUCTION* (1969) of SALVATORE MARTIRANO. This hybrid system evolved over several years with the help of many colleagues and students at the University of Illinois. Considered by Martirano to be a composition unto itself, the machine consisted of a motley assortment of custom-built analog and digital circuitry controlled from a completely unique interface and distributed through multiple channels of loudspeakers suspended throughout the performance space. Martirano describes his work as follows:

*"The SAL-MAR CONSTRUCTION was designed, financed and built in 1969-1972 by engineers Divilbiss, Franco, Borovec and composer Martirano here at the University of Illinois. It is a hybrid system in which TTL logical circuits (small and medium scale integration) drive analog modules, such as voltage-controlled oscillators, amplifiers and filters. The SMC weighs 1500lbs crated and measures 8'x5'x3'.*

*It can be set-up at one end of the space with a 'spider web' of speaker wire going out to 24 plexiglass enclosed speakers that hang in a variety of patterns about the space. The speakers weigh about 6lbs. each, and are gently mobile according to air currents in the space. A changing pattern of sound-traffic by 4 independently controlled programs produces rich timbres that occur as the moving source of sound causes the sound to literally bump into itself in the air, thus effecting phase cancellation and addition of the signal.*

*The control panel has 291 touch-sensitive set/reset switches that are patched so that a tree of diverse signal paths is available to the performer. The output of the switch is either set 'out1' or reset 'out2'. Further the 291 switches are multiplexed down 4 levels. The unique characteristic of the switch is that it can be driven both manually and logically, which allows human/machine interaction.*



*Most innovative feature of the human/machine interface is that it allows the user to switch from control of macro to micro parameters of the information output. This is analogous to a zoom lens on a camera. A pianist remains at one level only, that is, on the keys. It is possible to assign performer actions to AUTO and allow the SMC to make all decisions."*

One of the major difficulties with the hybrid performance systems of the late 1960's and early 1970's was the sheer size of digital computers. One solution to this problem was presented by GORDON MUMMA in his composition *Conspiracy 8* (1970). When the piece was presented at New York's Guggenheim Museum, a remote data-link was established to a computer in Boston which received information about the performance in progress. In turn this computer then issued instructions to the performers and generated sounds which were also transmitted to the performance site through data-link.

Starting in 1970 an ambitious attempt at using the new mini-computers was initiated by Ed Kobrin, a former student and colleague of Martirano's. Starting in Illinois in collaboration with engineer Jeff Mack, and continuing at the Center for Music Experiment at the University of California, San Diego, Kobrin designed an extremely sophisticated hybrid system (actually referred to as *HYBRID I THROUGH V*) that interfaced a mini-computer to an array of voltage-controlled electronic sound modules. As a live performance electronic instrument, its six-voice polyphony, complexity and speed of interaction made it the most powerful realtime system of its time. One of its versions is described by Kobrin:

*"The most recent system consists of a PDP 11 computer with 16k words of core memory, dual digital cassette unit, CRT terminal with ASCII keyboard, and a piano-type keyboard. A digital interface consisting of interrupt modules, address decoding circuitry, 8 and 10 bit digital to analog converters with holding registers, programmable counters and a series of tracking and status registers is hardwired to a synthesizer. The music generated is distributed to 16 speakers creating a controlled sound environment."*

Perhaps the most radical and innovative aspect of live electronic performance practice to emerge during this time was the appearance of a new form of collective music making. In Europe, North America and Japan several important groups of musicians began to collaborate in collective compositional, improvisational, and theatrical activities that relied heavily upon the new electronic technologies. Some of the reasons for this trend were: 1) the performance demands of the technology itself which often required multiple performers to accomplish basic tasks; 2) the





improvisatory and open-ended nature of some of the music was friendly and/or philosophically biased towards a diverse and flexible number of participants; and 3) the cultural and political climate was particularly attuned to encouraging social experimentation.

As early as 1960, the ONCE Group had formed in Ann Arbor, Michigan. Comprised of a diverse group of architects, composers, dancers, filmmakers, sculptors and theater people, the ONCE GROUP presented the annual ONCE FESTIVAL. The principal composers of this group consisted of George Cacioppo, Roger Reynolds, Donald Scavarda, Robert Ashley and Gordon Mumma, most of whom were actively exploring tape music and developing live electronic techniques. In 1966 Ashley and Mumma joined forces with David Behrman and Alvin Lucier to create one of the most influential live electronic performance ensembles, the *SONIC ARTS UNION*. While its members would collaborate in the realization of compositions by its members, and by other composers, it was not concerned with collaborative composition or improvisation like many other groups that had formed about the same time.

Concurrent with the ONCE Group activities were the concerts and events presented by the participants of the San Francisco Tape Music Center such as Pauline Oliveros, Terry Riley, Ramon Sender and Morton Subotnick. Likewise a powerful center for collaborative activity had developed at the University of Illinois, Champaign/Urbana where Herbert Brün, Kenneth Gaburo, Lejaren Hiller, Salvatore Martirano, and James Tenney had been working. By the late 1960's a similarly vital academic scene had formed at the University of California, San Diego where Gaburo, Oliveros, Reynolds and Robert Erickson were now teaching.

In Europe several innovative collectives had also formed. To perform his own music Stockhausen had gathered together a live electronic music ensemble consisting of Alfred Alings, Harald Boje, Peter Eötvös, Johannes Fritsch, Rolf Gehlhaar, and Aloys Kontarsky. In 1964 an international collective called the Gruppo di Improvisazione Nuova Consonanza was created in Rome for performing live electronic music. Two years later, Rome also saw the formation of Musica Elettronica Viva, one of the most radical electronic performance collectives to advance group improvisation that often involved audience participation. In its original incarnation the group included Allan Bryant, Alvin Curran, John Phetteplace, Frederic Rzewski, and Richard Teitelbaum.

The other major collaborative group concerned with the implications of electronic technology was AMM in England. Founded in 1965 by jazz musicians Keith Rowe, Lou Gare and Eddie Provost, and the experimental genius Cornelius Cardew, the group focused its energy into highly eclectic but disciplined improvisations with electro-acoustic materials. In many ways the group was an intentional social experiment the experience of which deeply



informed the subsequent Scratch Orchestra collective of Cardew's.

One final category of live electronic performance practice involves the more focused activities of the Minimalist composers of the 1960's. These composers and their activities were involved with both individual and collective performance activities and in large part confused the boundaries between the so-called "serious" avant-garde and popular music. The composer TERRY RILEY exemplifies this idea quite dramatically. During the late 1960's Riley created a very popular form of solo performance using wind instruments, keyboards and voice with tape delay systems that was an outgrowth from his early experiments into pattern music and his growing interest in Indian music. In 1964 the New York composer LaMonte Young formed *THE THEATRE OF ETERNAL MUSIC* to realize his extended investigations into pure vertical harmonic relationships and tunings. The ensemble consisted of string instruments, singing voices and precisely tuned drones generated by audio oscillators. In early performances the performers included John Cale, Tony Conrad, LaMonte Young, and Marian Zazeela.

A very brief list of significant live electronic music works of the 1960's is the following:

1960) Cage: *CARTRIDGE MUSIC*

1964) Young: *The Tortoise, His Dreams and Journeys*; Sender: *Desert Ambulance*; Ashley: *Wolfman*; Stockhausen: *Mikrophonie I*

1965) Lucier: *Music for Solo Performer*

1966) Mumma: *MESA*

1967) Stockhausen: *PROZESSION*; Mumma: *HORNPIPE*

1968) Tudor: *RAINFOREST*; Behrman: *RUNTHROUGH*

1969) Cage and Hiller: *HPSCHD*; Martirano: *Sal-Mar Construction*; Mizelle: *Photo Oscillations*

1970) Rosenboom: *Ecology of the Skin*

#### 4) MULTI-MEDIA

The historical antecedants for mixed-media connect multiple threads of artistic traditions as diverse as theatre, cinema, music,

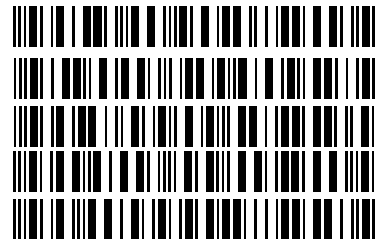

sculpture, literature, and dance. Since the extreme eclecticism of this topic and the sheer volume of activity associated with it is too vast for the focus of this essay, I will only be concerned with a few examples of mixed-media activities during the 1960's that impacted the electronic art and music traditions from which subsequent video experimentation emerged.

Much of the previously discussed live electronic music of the 1960's can be placed within the mixed-media category in that the performance circumstances demanded by the technology were intentionally theatrical or environmental. This emphasis on how technology could help to articulate new spatial relationships and heightened interaction between the physical senses was shared with many other artists from the visual, theatrical and dance traditions. Many new terms arose to describe the resulting experiments of various individuals and groups such as "happenings," "events," "action theatre," "environments", or what Richard Kostelanetz called "The Theatre of Mixed-Means." In many ways the aesthetic challenge and collaborative agenda of these projects was conceptually linked to the various counter-cultural movements and social experiments of the decade. For some artists these activities were a direct continuity from participation in the avant-garde movements of the 1950's such as Fluxus, electronic music, "kinetic sculpture," Abstract Expressionism and Pop Art, and for others they were a fulfillment of ideas about the merger of art and science initiated by the 1930's Bauhaus artists.

Many of the performance groups already mentioned were engaged in mixed-media as their principal activity. In Michigan, the *ONCE Group* had been preceded by the *Manifestations: Light and Sound performances* and *Space Theatre* of Milton Cohen as early as 1956. The filmmaker Jordan Belson and Henry Jacobs organized the *Vortex* performances in San Francisco the following year. Japan saw the formation of Tokyo's *Group Ongaku* and Sogetsu Art Center with Kuniharu Akiyama, Toshi Ichianagi, Joji Yuasa, Takahisa Kosugi, and Chieko Shiomi in the early 1960's. At the same time were the ritual oriented activities of LaMonte Young's *THE THEATRE OF ETERNAL MUSIC*. The group *Pulsa* was particularly active through the late sixties staging environmental light and sound works such as the *BOSTON PUBLIC GARDENS DEMONSTRATION* (1968) that used 55 xenon strobe lights placed underwater in the garden's four-acre pond. On top of the water were placed 52 polyplanar loudspeakers which were controlled, along with the lights, by computer and prerecorded magnetic tape. This resulted in streams of light and sound being projected throughout the park at high speeds. At the heart of this event was the unique *HYBRID DIGITAL/ANALOG AUDIO SYNTHESIZER* which *Pulsa* designed and used in most of their subsequent performance events.

In 1962, the USCO formed as a radical collective of artists and

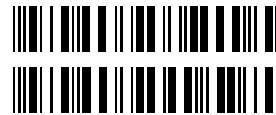

engineers dedicated to collective action and anonymity. Some of the artists involved were Gerd Stern, Stan Van Der Beek, and Jud Yalkut. As Douglas Davis describes them:

*“USCO’s leaders were strongly influenced by McLuhan’s ideas as expressed in his book **Understanding Media**. Their environments—performed in galleries, churches, schools, and museums across the United States—increased in complexity with time, culminating in multiscreen audiovisual “worlds” and strobe environments. They saw technology as a means of bringing people together in a new and sophisticated tribalism. In pursuit of that ideal, they lived, worked, and created together in virtual anonymity.”*

The influence of McLuhan also had a strong impact upon John Cage during this period and marks a shift in his work toward a more politically and socially engaged discourse. This shift was exemplified in two of his major works during the 1960’s which were large multi-media extravaganza’s staged during residencies at the University of Illinois in 1967 and 1969: *Musicircus* and *HPSCHD*. The later work was conceived in collaboration with Lejaren Hiller and subsequently used 51 computer-generated sound tapes, in addition to seven harpsichords and numerous film projections by Ronald Nameth.

Another example of a major mixed-media work composed during the 1960’s is the *TEATRO PROBABILISTICO III* (1968) for actors, musicians, dancers, light, TV cameras, public and traffic conductor by the brazilian composer JOCY DE OLIVEIRA. She describes her work in the following terms that are indicative of a typical attitude toward mixed-media performance at that time:

*“This piece is an exercise in searching for total perception leading to a global event which tends to eliminate the set role of public versus performers through a complementary interaction. The community life and the urban space are used for this purpose. It also includes the TV communication on a permutation of live and video tape and a transmutation from utilitarian-camera to creative camera.*

*The performer is equally an actor, musician, dancer, light, TV camera/video artist or public. They all are directed by a traffic conductor. He represents the complex contradiction of explicit and implicit. He is a kind of military God who controls the freedom of the powers by dictating orders through signs. He has power over everything and yet he cannot predict everything. The performers improvise on a time-event structure, according to general directions. The number of performers is determined by the space possibilities. It is preferable to use a downtown pedestrian area.*

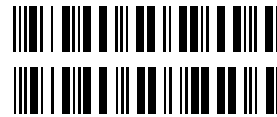

*The conductor should be located in the center of the performing area visible to the performers (over a platform). He should wear a uniform representing any high rank.*

*For the public as well as the performers this is an exercise in searching for a total experience in complete perception."*

One of the most important intellectual concerns to emerge at this time amongst most of these artists was an explicit embracing of technology as a creative counter-cultural force. In addition to McLuhan, the figure of Buckminster Fuller had a profound influence upon an entire generation of artists. Fuller's assertion that the radical and often negative changes wrought by technological innovation were also opportunities for proper understanding and redirection of resources became an organizing principle for vanguard thinkers in the arts. The need to take technology seriously as the social environment in which artists lived and formulated critical relationships with the culture at large became formalized in projects such as *Experiments in Art and Technology, Inc.* and the various festivals and events they sponsored: *Nine Evenings: Theater and Engineering*; *Some More Beginnings*; the series of performances presented at *Automation House* in New York City during the late 1960's; and the *PEPSI-COLA PAVILION FOR EXPO 70* in Osaka, Japan. One of the participants in Expo 70, Gordon Mumma, describes the immense complexity and sophistication that mixed-media presentations had evolved into by that time:



*"The most remarkable of all multi-media collaborations was probably the Pepsi-Cola Pavilion for Expo 70 in Osaka. This project included many ideas distilled from previous multi-media activities, and significantly advanced both the art and technology by numerous innovations. The Expo 70 pavilion was remarkable for several reasons. It was an international collaboration of dozens of artists, as many engineers, and numerous industries, all coordinated by Experiments in Art and Technology, Inc. From several hundred proposals, the projects of twenty-eight artists and musicians were selected for presentation in the pavilion. The outside of the pavilion was a 120-foot-diameter geodesic dome of white plastic and steel, enshrouded by an ever-changing, artificially generated water-vapor cloud. The public plaza in front of the pavilion contained seven man-sized, sound-emitting floats, that moved slowly and changed direction when touched. A thirty-foot polar heliostat sculpture tracked the sun and reflected a ten-foot-diameter sun-beam from its elliptical mirror through the cloud onto the pavilion. The inside of the pavilion consisted of two large spaces, one black-walled and clam-shaped, the other a ninety-foot high hemispherical mirror dome. The sound and light environment of these spaces*

was achieved by an innovative audio and optical system consisting of state-of-the-art analog audio circuitry, with krypton-laser, tungsten, quartz-iodide, and xenon lighting, all controlled by a specially designed digital computer programming facility.

The sound, light, and control systems, and their integration with the unique hemispherical acoustics and optics of the pavilion, were controlled from a movable console. On this console the lighting and sound had separate panels from which the intensities, colors, and directions of the lighting, pitches, loudness, timbre, and directions of the sound could be controlled by live performers. The sound-moving capabilities of the dome were achieved with a rhombic grid of thirty-seven loudspeakers surrounding the dome, and were designed to allow the movement of sounds from point, straight line, curved, and field types of sources. The speed of movement could vary from extremely slow to fast enough to lose the sense of motion. The sounds to be heard could be from any live, taped, or synthesized source, and up to thirty-two different inputs could be controlled at one time. Furthermore, it was possible to electronically modify these inputs by using eight channels of modification circuitry that could change the pitch, loudness, and timbre in a vast number of combinations. Another console panel contained digital circuitry that could be programmed to automatically control aspects of the light and sound. By their programming of this control panel, the performers could delegate any amount of the light and sound functions to the digital circuitry. Thus, at one extreme the pavilion could be entirely a live-performance instrument, and at the other, an automated environment. The most important design concept of the pavilion was that it was a live-performance, multi-media instrument. Between the extremes of manual and automatic control of so many aspects of environment, the artist could establish all sorts of sophisticated man-machine performance interactions."



## CONSOLIDATION: THE 1970 AND 80'S

The beginning of the 1970's saw a continuation of most of the developments initiated in the 1960's. Activities were extremely diverse and included all the varieties of electronic music genres previously established throughout the 20th century. Academic tape studios continued to thrive with a great deal of unique custom-built hardware being conceived by engineers, composers and students. Hundreds of private studios were also established as the price of technology became more affordable for individual artists. Many more novel strategies for integrating tape and live performers were advanced as were new concepts for live electronics and multi-media. A great rush of activity in new circuit design



also took place and the now familiar pattern of continual miniaturization with increased power and memory expansion for computers began to become evident. Along with this increased level of electronic music activity two significant developments became evident: 1) what had been for decades a pioneering fringe activity within the larger context of music as a cultural activity now begins to become dominant; and 2) the commercial and sophisticated industrial manufacturing of electronic music systems and materials that had been fairly esoteric emerges in response to this awareness. The result of these new factors signals the end of the pioneering era of electronic music and the beginning of a post-modern aesthetic that is predominantly driven by commercial market forces.

By the end of the 1970's most innovations in hardware design had been taken over by industry in response to the emerging needs of popular culture. The film and music "industries" became the major forces in establishing technical standards which impacted subsequent electronic music hardware design. While the industrial representationist agenda succeeded in the guise of popular culture, some pioneering creative work continued within the divergent contexts of academic tape studios and computer music research centers and in the non-institutional aesthetic research of individual composers. While specialized venues still exist where experimental work can be heard, it has been an increasing tendency that access to such work has gotten progressively more problematic.

One of the most important shifts to occur in the 1980's was the progressive move toward the abandonment of analog electronics in favor of digital systems which could potentially recapitulate and summarize the prior history of electronic music in standardized forms. By the mid-1980's the industrial onslaught of highly redundant MIDI interfaceable digital synthesizers, processors, and samplers even began to displace the commercial merchandizing of traditional acoustic orchestral and band instruments. By 1990 the presence of these commercial technologies had become a ubiquitous cultural presence that largely defined the nature of the music being produced.

## CONCLUSION

What began in this century as a utopian and vaguely Romantic passion, namely that technology offered an opportunity to expand human perception and provide new avenues for the discovery of reality, subsequently evolved through the 1960's into an intoxication with this humanistic agenda as a social critique and counter-cultural movement. The irony is that many of the artist's who were most concerned with technology as a counter-cultural



social critique built tools that ultimately became the resources for an industrial movement that in large part eradicated their ideological concerns. Most of these artists and their work have fallen into the anonymous cracks of a consumer culture that now regards their experimentation merely as inherited technical R & D. While the mass distribution of the electronic means of musical production appears to be an egalitarian success, as a worst case scenario it may also signify the suffocation of the modernist dream at the hands of industrial profiteering. To quote the philosopher Jacques Attali: *“What is called music today is all too often only a disguise for the monologue of power. However, and this is the supreme irony of it all, never before have musicians tried so hard to communicate with their audience, and never before has that communication been so deceiving. Music now seems hardly more than a somewhat clumsy excuse for the self-glorification of musicians and the growth of a new industrial sector.”*

From a slightly more optimistic perspective, the current dissolving of emphasis upon heroic individual artistic contributions, within the context of the current proliferation of musical technology, may signify the emergence of a new socio-political structure: the means to create transcends the created objects and the personality of the object’s creator. The mass dissemination of new tools and instruments either signifies the complete failure of the modernist agenda or it signifies the culminating expression of commoditization through mass production of the tools necessary to deconstruct the redundant loop of consumption. After decades of selling records as a replacement for the experience of creative action, the music industry now sells the tools which may facilitate that creative participation. We shift emphasis to the means of production instead of the production of consumer demand.

Whichever way the evolution of electronic music unfolds will depend upon the dynamical properties of a dialectical synthesis between industrial forces and the survival of the modernist belief in the necessity for technology as a humanistic potential. Whether the current users of these tools can resist the redundancy of industrial determined design biases, induced by the clichés of commercial market forces, depends upon the continuation of a belief in the necessity for alternative voices willing to articulate that which the status quo is unwillingly to hear.

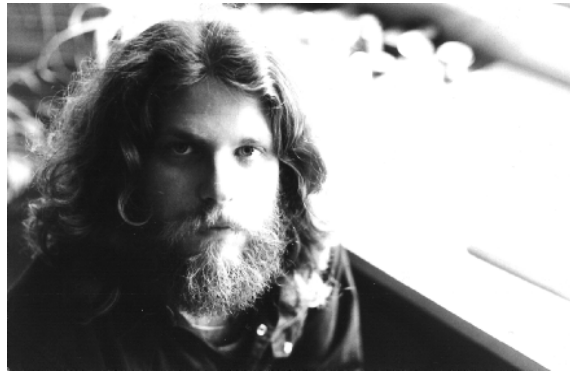

David Dunn, 1970s



# VIDEO: STATE OF THE ART

The Rockefeller Foundation, 1976

J o h a n n a B r a n s o n G i l l

## INTRODUCTION

*"Video was the most shared, the most democratic art form. . . . Everybody believed deeply that he had invented feedback. Feedback was invented simultaneously not by five people, like electricity, but by five thousand."*

—Woody Vasulka

When one begins to think about video, it is important to keep in mind its immense flexibility as a medium. It is not only TV, the standard piece of American living room furniture, it is also a material for making electronic graphics, the surveillance system in the neighborhood supermarket, the training tool that shows all too instantly what kind of teacher or tennis player you are, and a means of documenting almost anything from the SLA burn-out in Los Angeles to a grandmother's memories of her childhood. In other words, the video world is much larger than the art world, and people who make video art may have very diverse backgrounds in the medium. Consequently, the term "video art" does not describe any single unified style; it indicates a shared medium.

Most video art-making began in 1968 and 1969. The social and artistic ferment of those years had a great deal to do with the way the medium was first used. Nineteen sixty-eight also marks a technical watershed: it was the year portable, relatively inexpensive television equipment came on the market, thus opening the medium to a vast new group of people. Although these people were interested in the equipment for many different reasons, most of them shared an acute dissatisfaction with broadcast television. They were unhappy with the monolithic nature of TV, with the control of three major net-

works, with the quality of programming—the lack of diverse content and the routine visual sameness of it all.

This reaction against broadcast television is usually discernible in much early video. Some experimenters took their new light cameras out into the streets and to the countryside, recording people and social situations broadcast TV never would have bothered with. This group of people was concerned with exploring as rich an array of subjects as possible. They felt broadcast TV had developed bland programming in an effort to offend as few people as possible, attract high ratings, and thus command higher prices for advertising time. The alternative television people were not supported by advertising; they didn't care about ratings. They were free to focus their cameras on anything, even things that would interest only the people living in a single neighborhood.

Others were concerned with electronics research and development. These people considered it ridiculous that the perfect television image was thought to be the smooth, glowing pink face of Walter Cronkite. Some of these experimenters come from a strong twentieth century graphic tradition of exploration with light imagery going back at least as far as the Futurists and the Bauhaus. Those who had been looking for a medium of moving, colored light were overjoyed to find that television could produce abstract images as easily as it could transmit a newscaster's face. Some members of this group built new electronic circuitry to produce different imagery. These people are among the real pioneers of the medium; they are fascinated with the role technology plays in our society and are constantly searching for new ways to make this role visually manifest. They feel that the structure of electronic

tools reflects as well as informs our thinking, and by using tools that produce visual patterns, they hope to reveal to us our social and technological directions.

Still another group was reacting against the one-directional flow of broadcast TV, which streams day after day into the homes of millions of people without providing the means for them to speak back equally directly. They pointed out that we have only receivers in our homes, not transmitters, and sometimes these people set up small, closed-circuit environments that contained both cameras and monitors. Often the earliest such environments held banks of monitors; one could see one's own image (being picked up by cameras in the room) on monitors next to others showing programs coming off the air. In this manner, a viewer could explore the idea that his or her image was as interesting as that of a quiz-show personality. Many of those who created environments were fundamentally interested in the nature of visual and aural information, in how we receive and digest it, and how it affects us, both consciously and unconsciously.

During the time this reaction against broadcast television was going on (1967-1970), the established art world was facing some challenges of its own. Many artists found that the traditions of painting and sculpture had arrived at a critical cul-de-sac, and they were searching for other means of expression. In addition, the commercial art world was in the midst of escalating prices and wild buying, a situation further confused by a prevailing indecision about the relative merits of different kinds of art.

One result of this atmosphere of change was the reaction of some artists against the production of art objects: they preferred to work in nonbuyable, nonpossessable media, partly in an attempt to free themselves from the art market as it was then functioning. Consequently, there was an explosion of new kinds of art, most of them either variations on performance, theater, and dance, or mechanically reproducible art forms such as photography, film, and video. Video fell into this art world very neatly. It could be used to record all kinds of performances and actions, enabling them to be repeated again and again. It could either be abstract or representational in its imagery (it was not inherently one or the other), and so side-stepped certain critical dilemmas. A few galleries and museums began to collect tapes, hire curators, and organize exhibitions.

The following discussion is not a comprehensive history of the first years of interest in video as a creative medium, but is rather an attempt to chart some of the ways the energy has flowed and to introduce a few of the more interesting people and situations. In general, one might say that art-making has occurred in three areas of video activity—these are arbitrary divisions, but are useful descriptively. One is the aforementioned realm of electronics research and development. Because of its roots in other twentieth-century graphic traditions, this is often the work most accessible to people first looking at the medium. Examples include the famous “synthesizer” tapes and special effects graphics of many kinds. A second area of activity has been documentary, an area that is currently interesting historians and critics of photography and film as well. The third area is probably the most complex. It includes performances, conceptual work and what may be called information-perception pieces. This group includes both video tapes and live video installations that in some way expand the limits of the viewer's ability to perceive himself or herself in a technologically charged environment.

## HISTORICAL NOTES

### Individuals and Small Groups

A few rumblings in the early sixties anticipated the general eruption of interest in the medium later in the decade. **NAM JUNE PAIK** —



FRAME 48 step through next 16 frames

is probably the most famous and certainly one of the most interesting members of the movement; his work is a collage of all three divisions of video activity. He was born in Korea and was educated in Japan and Germany, where he studied philosophy and music. By his own estimate, he has given over 100 performances, which reflect his interest in avant-garde music (John Cage is a major influence) and the Fluxus movement. His first exhibition of television was in Germany in 1963, in which he showed television sets whose off-the-air images were distorted. By 1965, Paik had moved to New York and was having exhibitions here. His work takes many forms—video performances and video



STEP BACK



STEP FORWARD



INFO frame 6078 to 7423

installations as well as video tapes—and shows his interest in process rather than product; the new often has elements carried forward from the old.

Paik has always been on the outer fringes of the movement technically. In 1965, he bought one of Sony's first portable video tape recorders and displayed tapes the same night. He was the co-developer, with SHUYA ABE, —



FRAME 060

of one of the first video synthesizers. Several people were working on synthesizers in 1968 and 1969 and each machine reflects the desires of its builder. They have in common the ability to produce dazzling color patterns and forms, moving and shifting through time. The Paik-Abe synthesizer is the perfect tool for Paik's work—it takes black-and-white camera images and mixes and colorizes them, producing dense, often layered, brilliantly colored fragments.

Paik's basic style is one that has become familiar in this century, a collage of juxtaposed pieces of information wrenched out of their original contexts. His taped work constantly reshuffles bits and pieces of material from all over the world—a Korean drummer in action, Japanese Pepsi commercials, go-go dancers, tapes of his own performances with cellist CHARLOTTE MOORMAN. —



FRAME 047

He has spoken of how we live in an age of information overkill; his fast-paced, disjunct, percussive tapes heighten and intensify this barrage of image and sound. The effect is jolting. Paik makes the viewer stop and think, and he does this not only in his performances and tapes: his production of enigmatic, deadpan aphorisms is second only to Andy Warhol's in the world of art. "I would rather be corrupted than repeat the sublime," he said with a chuckle during a televised interview with Russell Connor and Calvin Tompkins.

ERIC SIEGEL —



FRAME 086 step through next 3 frames

was another forerunner. He began building TV sets in high school and has continued building video equipment ever since. He was also the builder of an



STEP BACK



STEP FORWARD

early video synthesizer, and another tool, his colorizer, has been used by half the artists in the country who want color in their tapes. Siegel's own work ranges from an early special-effects tape of Einstein to more recent personal documentary tapes.

A third early experimenter, and one who has remained steadfastly independent of any group affiliation, is Les Levine. In 1968, after he had been working with video tape for some time, he presented the first public showing of his work. As the audience watched his prerecorded video tapes on such subjects as the destruction of art and the nude model, they could also watch their own reactions on a closed-circuit monitor: Levine had a camera in the room. This is typical of his work—Levine is not interested in traditional aesthetics, but with television environments, with the movement of information within physical and temporal limits. He was quoted in a *New York Times* review as saying that he hoped to help people form new images of themselves by showing them their reactions to what they see. "They'll change as they note their responses to various situations presented on the tapes. . . . If you see yourself looking self-conscious, for example, you'll be forced to think why."

Also in 1968, Levine produced his first "television sculpture," *Iris*. Once again, Levine had the viewer confronting himself via television. In this case, all the hardware for the closed-circuit system was contained in one eight-foot-tall sculpture-console. Standing in front of this console, the viewer faced six monitors and three concealed video cameras. The cameras shot the space in front of the console, and presented views of the environment in close-up, middle distance, and wide angle. Each of these cameras had its own monitor and the three others provided distorted images that might or might not be recognizable. Thus, a viewer standing in front of the console could see three different views of himself juxtaposed with other random video information.

In this early work, Levine opened an examination of television as an information system of great flexibility and complexity. This aspect of the medium has been further explored with increasing subtlety and sophistication by several artists in the years since Levine made *Iris*.

By 1968, inexpensive portable equipment was becoming widely available. During the next year or so, various people bought cameras and video tape



INFO frame 11300 to 14925

recorders (portapaks) and experimented with them alone or in small groups. A group of graduating college seniors in Santa Clara, California, was typical: one of them had invested in a portapak, and he and his friends used it so constantly that it finally wore out. Most of that group have continued their interest in video, and two will be discussed later—George Bolling, who is the video curator at the de Saisset Art Gallery in Santa Clara and introduced a whole generation of San Francisco artists to the medium, and Skip Sweeney, who co-founded Video Free America, a San Francisco group that, among other things, sponsored some of the earliest video theater.

In New York, Commediation appeared. It was the first of a long series of video groups to emerge. David Cort, Frank Gillette, Ken Marsh, and Howie Gutstadt were members, and like many people initially attracted to the medium, they were primarily interested in video as a tool for social change. A little of David Cort's history may help to illuminate the motives of many people working in video.

Cort had originally been involved in the theater, but the late 1960's found him working at the Brooklyn Children's Museum, involved in antipoverty outreach programs.

*I got started in documentary work in political things, attempting to bring together divergent peoples. . . . I was overwhelmed by the lightness of the video camera, the intimacy of it, the way you could talk from behind the camera to people and they could talk to you looking at the camera. The camera was like a funnel through which you could work. You could move in, and be intimate and close.*

Cort was impressed with the flexibility of the medium, and dissatisfied with how it was used in broadcast:

*I look at TV and it's so passive. "Feed me information, tell me what to feel, tell me what to believe, and I'll sit there and take it in." Walter Cronkite tells you what to believe.*

*...I'd rather have lots of different individuals involved, so you would have a lot of different viewpoints, ideas, instead of one. Walter Cronkite tries to tell you that he has no viewpoint, that he's objective; "That's the way it is." The whole story is held*

*together by his personality; it centers around him. I found that to be uninteresting.*

Cort was further disenchanted with TV because of an uncomfortable experience he and his wife had had on a daytime TV show. They had felt overwhelmed, humiliated, and manipulated, and the experience influenced Cort's own work:

*It has become a basic esthetic. It's like a rule. Whenever I work in video, everybody I work with has to have a feed, has to see what's going on. Nothing can be hidden. One of the things I object to most about journalism is that people come in and they take your picture, and you don't know what they're taking. They may play it back to you afterwards, but that's not the same as seeing it while it's there.*

He goes on to say:

*You know, I think a lot of people are in video because they have no choice—it's so overwhelmingly around you. It's almost like a responsibility that you have to take, that you have to work with it because it's all-pervasive. We are confronted with this alien, cold equipment and we are to make something human, to involve the human being in it in some way, to make him active, to make him participate. At one and the same time you want to control it and you want to destroy it, you want to remove it and get back to the romantic, but you can't. So you are faced with it and you have to do something with it that will be fun, that will be joyous, that will be human rather than antihuman, that will be positive.*

It is exciting to hear conversations about the first few months of experimentation. In New York City, people carrying portapaks bumped into each other on the street or at parties and got to know each other; the famous concert at Woodstock in 1969 was yet another meeting place. Many video groups formed quite rapidly, and often just as rapidly some of them dissolved, but the cast of characters remained remarkably constant. Most of them, as was the case with the group in San Francisco, are still at the heart of the medium today: Ira Schneider, Frank Gillette, David Cort, Beryl Korot, Ken Marsh, John Reilly, Rudi Stern, Parry Teasedale, Michael Shamberg, to mention only a few of them.

The artist Bruce Nauman, in 1967, used video as

part of a gallery installation; in 1968, he started to record his performances on video tape. And so, by the end of the first year of activity in the medium, several different uses had already been established: synthesizers were being constructed to produce new electronic imagery, documentary tapes were being made, and the medium was beginning to be explored by conceptual artists to record performances and gestures.

In 1969, artists who were not already acquainted found themselves looking at each other's work at the first large gallery exhibition, "Television as a Creative Medium," a display that was organized by Howard Wise. Wise has been one of the staunchest supporters of electronic arts in general, and video in particular. He has subsequently relinquished his Fifty-seventh Street gallery in order to support video full time, and is currently one of the largest distributors of artists' video tapes. At his Fifth Avenue headquarters, Electronic Arts Intermix, he also provides an open-access editing facility for artists. At his 1969 show, he gathered together video tapes and sponsored installations; the artists got to know each other, and several new video groups formed as a result. Also in 1969, WGBH-TV broadcast the first video "sampler," a half-hour program showing the work of six artists.

Video activity, by 1970, seemed to have all marks of a fullfledged art movement: there was a large museum show, a movement magazine appeared, art critics got involved, and official funding agencies were interested. First there was the exhibition at the Rose Art Museum at Brandeis University, organized by Russell Connor. Connor, like Howard Wise, has continued to be deeply involved in video and has indeed probably done more than anyone else to bring video art to a wide audience. This past year, for example, he hosted a series of twenty-two programs of various artists' work, broadcast over New York City's Channel 13. Many of the East Coast video artists and groups were represented at his Rose Art Museum Show, "Vision and Television."

Second, during the summer of 1970, the first issue of the video movement's magazine appeared. It was called *Radical Software*, and was published by Raindance Corporation. The early issues of the magazine conveyed the heady excitement of the times; they were packed full of drawings, how-to articles, names and addresses. Another avant-garde journal, *Avalanche*, also started publication in 1970;

one of its editors is Willoughby Sharp, a video-performance artist, and much of each issue has to do with video.

Third, two critics writing about video soon became involved in making it. Michael Shamberg was a reporter for *Time*; he became one of the founding members of Raindance Corporation, a group that, through *Radical Software* and other activities, served as information central in the video community. A while later, Shamberg co-founded TVTV, a video documentary group. Douglas Davis was and is the art critic for *Newsweek*; he has become an extremely prolific video artist as well.

Finally, in 1970, the New York State Council for the Arts became very involved in supporting video. The council has funded a wide variety of projects, centers, and individuals. The first years of the video movement had witnessed, for the most part, an openness and sharing among its members. Whether they were tinkering with synthesizers or out in the streets with portapak or building complicated gallery installations, they all considered themselves to be part of the same movement. By 1970-1971, however, divisions began to occur. The two major groups to emerge were "art video" and "social action video." And within the art group there were further subdivisions into "synthesizer video," "conceptual video," and so on. Splits probably occurred most often over problems in funding, a consistently difficult task for most video people. They do not fit into the traditional art marketing system at all and so have had to do much of their work on grants from the NEA, state councils, and the Rockefeller Foundation. They also have had difficulties in getting their work to audiences. Broadcast television has, with a few notable exceptions, been uninterested. Museums and galleries have begun a stream of exhibitions but these have taken awhile to catch on. Exhibitions of this sort must be arranged very carefully, as watching tapes of any length in a conventional gallery is not comfortable.

It is worth noting that in 1970-1971 many conceptual artists were attracted to the medium. It must have seemed like manna from heaven to a group searching for a new, inexpensive means of expressing complicated ideas, perceptions, and actions in time. Most conceptual artists were affiliated with galleries in one way or another, having shed earlier media, especially sculpture, which galleries could more or less adequately exhibit. At any rate,

they had a way of trying to absorb into the whole gallery system a medium that was not always comfortable within it, and of applying to the medium a complicated system of aesthetics derived from the critical dilemmas of painting and sculpture during the 1960's. Possibly this further deepened some of the previously mentioned divisions.

Eventually, although funding problems were far from solved, the different groups settled down and made subtle shifts to accommodate each other. It has been my experience that good art has come from every group; no one has a corner on philosophic or aesthetic quality. The most interesting synthesizer artists have grown from early color and pattern experiments (which earned them the title of "video wallpaper artists") to making rich statements. The most interesting conceptual artists have grown from applying preconceived ideas to the medium (which earned them the title of "boring academicians") to working within the medium, learning from it, integrating it into the fabric of their pieces.

Also, some of the galleries have worked very hard to distribute tapes in ways so that people can see them. The ambitious Castelli-Sonnabend Art Tapes Program is especially good. Under the direction of Joyce Nereaux, artists are asked to submit tapes of any type or length; the only specification (other than they meet the general tastes of the gallery) is that they be in a standard format.

### The Centers

Contemporary to this activity carried on by individuals was a sudden growth of interest in experimental television at three major broadcast centers: KQED in San Francisco, WGBH in Boston, and WNET in New York. KQED and WGBH were first off the mark; in 1967 they both received grants from the Rockefeller Foundation to establish experimental workshops in television. Brice Howard was the director of the first San Francisco workshop. During the first year, he asked five artists from the Bay area to come to the station, and he gave them access to the tools of television. They included a poet, a filmmaker, a novelist, a painter-sculptor, and a composer, Richard Felciano, who stayed with the workshop in following years. The TV director for the project was Bob Zagone, a young man who had been interested in innovative programming at KQED for some time. The experimenters found it increasingly

difficult to work within the structure of a broadcast station, using bits of studio time left over from the news productions. Howard gradually moved the program out of the KQED building and set up a separate, genuine workshop. The first-year artists, who were established in their own disciplines, were replaced during the ensuing years by people who concentrated on television itself (although they came from diverse backgrounds). The basic group came to include Willard Rosenquist, a professor of design at Berkeley; Bill Gwin, a young painter; Stephen Beck, an electronics designer; Don Hallock, a man with past experience both in broadcast TV and painting; Bill Roarty, a graphics designer who had also worked in television previously; and at various times two composers, first Richard Felciano and later Warner Jepson. In 1969, the workshop became the National Center for Experiments in Television (NCET), still under the direction of Brice Howard. Howard was an extraordinary man who provided an atmosphere where experimentation could go on free from pressures of a broadcast situation. The workshop gradually acquired and built equipment, and the members had time to learn the medium in a craftsmanlike fashion.

During the late 1960's and early 1970's, the Corporation for Public Broadcasting sponsored an internship program, in which TV personnel from around the country could come to the center to study. The center's current director, Paul Kaufman, described what happened:

*. . . what went on was the formation of a workshop environment into which came dozens and dozens of stunned producers and directors from all over the public broadcast stations . . . as a result, a lot of people in the system were exposed, and a lot of people in a sense went mad professionally, because Brice's personality and the general ambiance in the Center so strongly contrasted with the somewhat uptight and constrictive relationships at the stations.*

One of the people who "went mad professionally" was Bill Roarty, who came as an intern in 1969 and then came back to stay in 1971. His memories provide insight into the atmosphere at the center and into Howard's teaching:

*What happened in that six weeks was fascinating, because everything they were saying about televi-*

sion connected exactly with everything I had been told as a painting student. They were approaching it essentially the same way . . . it was material, it was surface. . . . The connection was obvious and immediate to me; the thing I was working in, television, was a medium, and I had never thought of it that way before.

. . . The idea that Brice spoke about so beautifully was that if you did divorce broadcast from the making of television, you can cut away an enormous amount of very conventionalized and superfluous ritual . . . the making of programs for broadcast in the old sense was at the very least manipulative, and not in any way connected to what I thought of as the creative process. It goes right down the line . . . you can examine the vocabulary people developed, "control room," "camera shots," etc. Broadcast was eliminated from our discussion but really it was included all the time, as a poor relative.

Roarty goes on to describe a typical day at the center, which at that time was in one huge room:

*Warner and I would be working on a complex sound composition and immediately to our left would be Stephen, designing a circuit and then on the other side of that would be Bill Gwin, looking at a tape, and over there would be Willard, working on light forms. You couldn't help but be completely excited by the thoughts and perceptions of all the people around you approaching things each in his own way.*

From 1971 on, the Rockefeller Foundation gave support to a new program of the center's. Paul Kaufman recalls:

*The time had come to try to see if you could do something about changing the moribund characteristics of teaching about television in the Universities. . . . We began a project that lasted for three years, which initially had people from the Center going out and visiting a lot of campuses, bringing tapes along, going to art departments, essentially saying to University people, "Look here, here's something new and something interesting, and you can do it. It's important to do it because we are going to have to train a whole new generation of image-sensitive people, and the schools aren't doing it." Well, out of this group of initial visits, about 5 or 6 places kind of*

*surfaced as possible workshop sites, and eventually these became more or less mini-Centers in themselves.*

The center entered a highly productive period in the spring of 1972. Don Hallock, Bill Gwin, Willard Rosenquist, and Bill Roarty all produced some of their most beautiful tapes. (Some of these tapes will be discussed in the third section of this report.) In the fall, Warner Jepson and Stephen Beck embarked on a concert tour around the country, giving performances with their audio and video synthesizers, respectively.

This burst of activity continued into the summer of 1973, when Don Hallock presented his "Videola" at the San Francisco Art Museum. Since that time, the direction of the center has been changing. There has been a shift from art to an interest in developing structural approaches to the medium. Paul Kaufman, the director, used the term "visual thinking" to describe his interest in finding a way of using all their experimentation of the preceding years to help figure out ways to get social, political, or philosophical ideas across on television without resorting to the traditional lecture form.

At any rate, the center as a place for aesthetic exploration is dissolving, and it leaves an empty space in the video world. Bill Gwin stumbled onto the old center in 1969 as a young painter, and here speaks about it as a place to learn:

*It was lucky for me because I learned how to use things in a very slow and unpressured way. When I was first there, they had one black and white camera and one tape machine, and that was all. They added more equipment slowly, so I started off with the most basic kind of situation, and over a period of three years learned how to use all of that equipment. It was nice; there's no place like it anymore, which is a problem.*

The workshop at WGBH-TV in Boston also was initially funded by the Rockefeller Foundation, but it took a very different direction from the National Center in San Francisco. No separate workshop was set up during the early years; instead, artists-in-residence embarked on special projects, and producers on the WGBH staff did innovative projects of their own as well. Thus, the experimentation was carried on within the structure of the station, in its

studios, using its equipment. Two producers at the station have been especially active. Fred Barzyck began after-hours experimenting with jazz programming in 1964. By 1969, he had produced *The Medium Is the Medium*, the first broadcast-TV program magazine of video artists' work, and he has continued to be wonderfully supportive of experimental work in the station. Even a partial list of his programs reveals a wide range of interests; he produced an early, free-form weekly series called *What's Happening, Mr. Silver?* in 1968, used the first portable color video equipment to do *Jean Shepherd's America* in 1971, tried a novel adaptation of Kurt Vonnegut's work for television, *Between Time and Timbuktu* in 1971-1972, and produced a second, larger document of the video movement for broadcast, *Video: The New Wave*, in 1973. Another producer, Rick Hauser, has concentrated on experimental drama and dance for television. He was an early Rockefeller artist-in-residence within the station, and he collaborated with playwright Mary Feldhaus-Weber on two programs. Both were composed of two tapes, broadcast over two channels simultaneously, and viewed by the home audience on two separate TV receivers. The first, *City/Motion/Space/Game*, in 1968, was a quick-paced exploration of various urban spaces by dancer Gus Solomons, Jr., with a sound score composed by John Morris, who electronically manipulated city sounds. The second, *Royal Flesh*, in 1969, was an Oedipal drama that implicated the viewer as the child of the myth. Hauser continues to work in a highly imaginative and structurally interesting way with dance and drama, pushing the medium in new directions.

The Rockefeller Foundation artist-in-residence program also brought Nam June Paik and filmmaker Stan Vanderbeek to broadcast television. Nam June began his year at WGBH in 1968-1969, doing a short segment for *The Medium Is the Medium*. He and Shuya Abe built their first video synthesizer there and first displayed its imagery in a four-hour-long blockbuster program called *Video Commune*, broadcast during the summer of 1970. The sound track was all of the Beatles' recorded music; people were invited off the streets to help contribute material (often their faces) for the synthesizer to process. Viewers at home watched four hours of dense, layered, slowly shifting, brilliantly colored images, some of which were recognizable

and some not. Stan Vanderbeek also put together a very large show, called *Violence Sonata*, which was broadcast in 1970. Vanderbeek had assembled many bits of material from which to choose, switching from one to another in real time as the show was broadcast. There were film clips of violent subject matter, a studio audience that included militant political groups, karate experts lunging at each other in the aisle, and so on. The result was typical of Vanderbeek's work at the time: a shotgun blast of information.

In 1972, another program was initiated at WGBH: the Music-Image Workshop, established by RON HAYS. (WGBH had been broadcasting music programs for several years, and in 1971 had broadcast *Video Variations*, a group of experimental visual pieces set to music played by the Boston Symphony Orchestra.) The relationship between sound and image has presented one of the thorniest problems to artists working with images in time. Many different solutions have been proposed, from using classical music for sound tracks, to composing music especially for each piece, to hooking up video and audio equipment so the sound and image are created together, to using no sound at all. Ron Hays addressed himself specifically to this problem, meeting with everyone who had given the matter serious thought.

He settled on using the Paik-Abe synthesizer as his video tool. It had no direct hook-up to music-generating equipment; it was operated manually. Hays spent months learning how to operate the synthesizer and gradually developed a "vocabulary" for it, that is, sets of images and patterns of movement he could draw upon at will. Hays said:

*At this point it was obvious that the Paik-Abe's potential visual configurations were so incredibly vast in number that some sort of discipline was demanded; some order and time structure had to be imposed if the results were to be enjoyed as anything beyond endless changing images. The structure of existing music would give me a structure within which I could produce and control and then choose the moving images.*

Thus, Hays settled on composing images with the Paik-Abe synthesizer to go with existing pieces of music, although he has worked with new music as well. He broadcast short works of video set to





specific pieces of music by various composers (Bach, Bartok, Stravinsky, Dvorak, Ravel, to name a few). Hays's first major work will be broadcast this year as part of the Norton Lectures delivered by Leonard Bernstein at Harvard University. The piece is set to the "Love-Death Prelude" from Wagner's *Tristan und Isolde*; the imagery is a complex sequence of video synthesis, computer animation, slit-scan animation, and other special visual effects.

Since February of 1974, experimental work at WGBH has shifted largely to the New Television Workshop, which inhabits a former movie theater in Watertown, Massachusetts. Managed by Dorothy Chiesa, the workshop houses a full one-half-inch-tape studio. The workshop has provided the first relatively open access to television equipment for local Boston artists, and has also invited artists like Peter Campus and William Wegman, who are already well-established in the medium, to make new tapes using the workshop facility. The workshop also has a mix of local and national talent in its special dance project, headed by Nancy Mason. The dance project continues WGBH's interest in combining dance and television, both by inviting choreographers and dancers to come to the workshop to experiment with the equipment, and by setting up a program to record existing dance of all kinds for archival purposes.

The third major center is the Television Laboratory at WNET in New York City, directed by David Loxton. It was established in 1972 with support from the Rockefeller Foundation and the New York State Council for the Arts, with special projects support from the National Endowment for the Arts. If the National Center in San Francisco was an introspective center for pure, broadcast-pressure-free research into the medium, and WGBH's workshops (until recently) existed within the fabric of the broadcast situation and nearly always put their work on the air in one form or another, the TV Lab at WNET has found a place between these two poles. During its first years, it purchased one of WNET's old black-and-white studios, Studio 46, and gradually added equipment until it is now one of the most elaborate color video studios in the country. During that year, the TV Lab also set up a mixed kind of access to the studio. Sometimes it was used by people already familiar with the medium; they participated in an artist-in-residence program (similar to the one at WGBH) in which special projects were

developed and some were aired. Sometimes the studio was made available for an artist-access program rather like the one KQED had its first year, in which people from many disciplines (sculpture, poetry, graphic design), some of them new to video, some of them not, come to try out the equipment.

Gradually, the TV Lab has devoted more and more of its time to an extended artist-in-residence program. John Godfrey, the TV Lab's engineer points out that it was very difficult due to limitations of time, to teach people new to the medium how to use the sophisticated equipment well enough to do anything new or different. At the end of the two or three weeks allotted to them, most people were still just beginning to learn the most basic image-making patterns. Since the TV Lab is the most elaborate installation of its kind, it has seemed more worthwhile to invite fewer people, who already know the basics of the medium, to process tapes they already have or to execute planned works, and to invite a few people new to the medium to come for long stays. At the same time, WNET is expanding its "broadcast access": Channel 13 broadcasts much more alternative television than just the tapes made at its own TV Lab. In fact, WNET has been the most consistent over-the-air outlet for unusual or experimental television of many kinds, from special-effects extravaganzas, to nightly sign-off pieces about New York City by Nam June Paik, to new kinds of documentary, or nonfiction, television.

During its first phase, which ended in the spring of 1974, a few works were made at the TV Lab that are among the classics of the video movement. In March, 1973, Ed Emshwiller's *Scape Mates* was broadcast. EMSHWILLER —



is a filmmaker known for his technical expertise and willingness to explore new visual effects. His work typically includes the human figure, and indeed seems like a special kind of dance. *Scape Mates* was one of the first attempts to marshal special effects in video and computer animation and to construct a rounded statement; up to this time, much exploration of special effects had been going on and many "sketches" had been made, but there had been little attempt to gather them together and create a finished work. In *Scape Mates*, figures journey slowly through dazzling electronic landscapes; the use of

the human figure interwoven with abstract electronic imagery can be an attempt to humanize the technology, but it also creates powerfully surreal images of people trapped in Escher-like mazes. Emshwiller has continued to mix the human figure and electronic imagery in two more pieces done at the TV Lab, *Pilobolus and Joan* and *Crossings and Meetings*. Two other major programs done during the first phase at the TV Lab were Nam June Paik's *Global Groove*, an international cultural collage, and Bill Gwin's *Sweet Verticality*, a poem about New York City to be discussed later.

The TV Lab also includes in its support video documentary, "nonfiction" television. In February, 1974, WNET broadcast *The Lord of the Universe*, a documentary about the guru Maharaj Ji, made by Top Value Television (TVT). It was a landmark in broadcast television because it was the first time an entire documentary was made for broadcast from one-half-inch-wide video tape. The portable, inexpensive video tape recorders (portapak)s record on one-half inch tape. The advantages of using such equipment for documentary are obvious: TVTV people could move quickly and unobtrusively into situations denied to big, bulky network equipment. However, for years this kind of tape was banned from broadcast because the image/signal quality was thought not good enough. By 1972, special machines, time-base correctors, existed that could regularize the signal of one-half-inch tape enough to convince TV engineers it was suitable for broadcast. A whole new range of material was potentially available for broadcast-TV audiences; the TV Lab commissioned a group of programs from TVTV for 1974-1975, and a four-part series on Washington (*Gerald Ford's America*) as well as a piece on Cajun Louisiana (*The Good Times Are Killing Me*) have been broadcast to date.

In the spring and summer of 1975, WNET broadcast a series called *Video and Television Review*, made at the TV Lab and hosted by Russell Connor. *VTR* was a magazine of shows about people who make alternate television of all kinds. The format varied from show to show; sometimes the program consisted almost entirely of an interview, as in *Nam June Paik: Edited for Television*, and sometimes it was wholly devoted to one work, as when Paik's *Global Groove* was broadcast. During the same spring, Paik himself made a series of vignettes about New York City, which were broadcast each night at

sign-off time. They went under the name *Suite 212* and have since been gathered into a single, typically collage-like tape.

## SELECTED PEOPLE AND SITUATIONS

### **Southern California: TVTV and Long Beach**

Top Value Television (TVTV) is a video documentary group that has headquarters in a house in West Los Angeles. It is a congregation of people who have backgrounds in various aspects of alternative television and print media; they came together to form TVTV in 1972. Their first project was to tape the Democratic and Republican national conventions of that year. Allen Rucker, a founding member of the group, explains:

*Our intention, and it's still our intention, was to change television. The politics of information, the politics of television, are what we are trying to alter. When we first went to the conventions in 1972, we set out to prove a point. The point was that we could take this dirt cheap black-and-white video equipment that cost \$1,500 for a whole unit, and twenty or thirty people who loved television . . . and demonstrate that you could take this low-cost technology and people who had not been wrung through the broadcast television system and make not only technically decent television but also television in which the information was shockingly different. The nature of the information was different; it was looser, more direct, more informal, more personal, and it was more visceral. You felt like you were there after watching the shows, as opposed to feeling someone had laid a rap on you.*

TVTV's attitude reflects a recent reevaluation of the term "documentary." For decades, media that are capable of mechanically recording and reproducing images (photography, film, and video) have been accepted as neutral witnesses of reality, as pure recording devices that take no stand on issues but merely reveal them. A comparison of network news documentaries of the conventions with TVTV's documentaries reveals that all recordings reflect in some way the thinking of those who make them. There is currently a booming interest in documentary film, photography, and video by artists, critics,

and historians, all people who heretofore would not have considered it of aesthetic interest. This is not to say that all of TVTV's techniques are original or that all of their video tapes are works of art. However, they are part of a movement to approach social material critically, as information, and they are working out experimental modes of journalism; so, in turn, they broaden our awareness of the medium itself.

TVTV's editing style is that of semi-chronological collage, with bits of information brushing against each other. The viewer doesn't receive information in narrative blocks; he is led through a process of meeting people, hearing conversations. At the end he has been told a story, but not in the conventional broadcast-TV way: an omnipotent narrative voice telling you what you're going to see, seeing something, and then being told once again what it is you have just seen.

The group feels a nostalgia for the old days of TV, when programs were live and the action was spontaneous. Allen Rucker says:

*All of a sudden what happened was that in the politics of commercial television those things became hardened into particular formats. Rather than Steve Allen talking to people on the street, Johnny Carson hardened the idea into the talk show. . . . If you watch Johnny Carson now, it's an amazing kind of ritual, and there's nothing spontaneous about it. If you've watched it once, you know every riff. Guests come out to promote themselves, and they are acting as if they are informal, but they are not informal.*

TVTV has set out to work in a way that would permit informality and spontaneity, recalling the immediacy that once seemed inherent in the medium. At the same time, they realize they are working in an incredibly media-conscious society, and that they cannot get away with being the proverbial fly on the wall while taping. Rucker explains:

*The whole idea behind cinema vérité was that the camera man did not exist . . . people would forget about him and there would be a kind of natural behavior. . . . It was an absolutely valid idea when it was first pursued because people had not learned . . . the process of television is not a product, it is an environment and it had not yet saturated them. Now*

*if you go in with a camera and play the direct cinema role . . . they are conscious of presenting themselves on television and thus create a conscious, unconscious style of behavior. . . . That's not our style. Our style is to make the camera an immediate element, making people know that we are shooting tape immediately, and not to make a big deal about it, not to say "stand over there," like the networks do, but to say "Yes, we're shooting. Here: want to look at it?" That's literally what we first did; we got people to shoot us and we attempted to make them relaxed in the presence of media rather than relaxed in the absence of media, which is what cinema vérité was attempting to do.*

TVTV is in a process of transition at the present time. They are the first to admit that they have failed to change television as a whole; there are not many independent video production groups getting their tapes on the air, providing a wide range of views. The problems of getting even one program on the air are many. The cycle of funding, shooting and editing, and finding an outlet is difficult to repeat indefinitely: TVTV avoided this by working for the TV Lab for a year as extended artists-in-residence, and they are now doing a series for KCET-TV in Los Angeles. But the problem of diversifying broadcast television in general remains.

The history of video in Southern California has been that of disjointed but enthusiastic activity. There has been a certain amount of video exhibited in the more avant-garde galleries in Los Angeles; Bruce Nauman began to show tapes at the Nicholas Wilder Gallery in 1968. In 1971, there was a burst of activity at the California Institute for the Arts; Allan Kaprow, John Baldessari, Gene Youngblood, Nam June Paik, and Shigeo Kubota, all of whom are involved in making or writing about video, were on the faculty.

Since that time, there has been an increasingly steady production of video tapes by independent artists. A new focus for their activity has appeared at the Long Beach Museum of Art, where David Ross became the deputy director for film and television in 1974. Ross had been video curator at the Everson Museum in Syracuse, New York, for nearly three years and had organized an astonishing number of exhibitions of video art. His forte has been his ability to find little-known artists and to organize their tapes, along with those of more famous artists, into



Gene Youngblood in the Vasulka's loft, ca. 1975, Buffalo, New York. Photo: Woody Vasulka

huge anthology-like exhibitions, providing a wide range of works for people to view. By the summer of 1975, he had managed to find an amazing number of tapes made in Southern California and had compiled them into an exhibition, "Southland Video Anthology."

Ross has worked very hard to find a way to exhibit tapes well in a gallery setting. He is only too aware that most museum goers operate in a cruise mode, and expect to be able to pick and choose what they want to look at, and to look only as long as their attention is held. Many video tapes are meant to be viewed from beginning to end, and a casual visitor may not be able to devote the necessary time. At the same time, it can be difficult to circumvent this problem by setting up precise viewing schedules, as is done for films, because there are so many tapes of varying lengths. Also, if turned into a kind of theatre-going experience, it would miss the viewer altogether, and a new art medium depends on chance encounters to build an audience. An added complication is that video is essentially an intimate medium, meant for small spaces, not large galleries.

Ross has worked out a good compromise. For the large exhibition at the Long Beach Museum, tapes run in several rooms. Some have regular schedules, with tapes playing in repeating cycles. Casual visitors can drop in, see what happens to be playing, and stay if they are interested. In other rooms, tapes are played by special request, so visitors with specific viewing desires can be accommodated. All the rooms are small and seating is comfortable, approximating a living room situation.

Most of the tapes shown at the "Southland Video Anthology" seem to be variations of recorded performance. In some cases, the artist addresses the camera directly, implicating the viewer as audience. In others, an actual performance in front of an audience has been recorded. The prevailing mood is one of fantasy—the tapes are full of little stories, narratives, games. When asked where this fascination with stories and narrative comes from, Ross had an immediate answer: "We're near Los Angeles, so what do you think? Hollywood." He went on to say that the two most influential people in local art schools have been artists John Baldessari and William Wegman, both of whom work with narrative structures.

One of the most intriguing tapes in the show was all about fantasy. It was Eleanor Antin's *The Little Match Girl Ballet*. Antin appears before an audience in full ballerina costume: she tells us she is going to New York to become a famous Russian ballerina. She fantasizes about her first big ballet, the story of the Little Match Girl. She slips into the story and remembers her first Christmas at home. Antin's finely woven performance fits fantasies one inside the other like Chinese boxes, until one has drifted far away from sure real/fantasy boundaries. It seemed an excellent, ironic performance to watch on a television set.

### **The Bay Area: San Francisco, Berkeley, Santa Clara**

The Bay area has provided a home for a wide variety of video, but it has existed there in isolated pockets. People have worked nearby for years and known nothing about each other's activities. The NCET is a prime example: it may have been a national center, but it was certainly never a local one. The work done there took the form of intense visual explorations in a narrow direction, so that the center existed like an island in the San Francisco art world, separate from most and unknown by many.

The working conditions at the center have been described earlier. For a variety of reasons, the early years of experimentation began to yield results in 1972-1973, when many interesting tapes were made. One characteristic shared by most of these tapes is a slowness of pace. The best tapes from this period at the center include Bill Gwin's and Warner Jepson's *Irving Bridge*, Willard Rosenquist's and Bill Roarty's

*Lostine*, Don Hallock's *Kiss With No Up*, and Bill Roarty's and Don Hallock's *Untitled*—in all of these there is an across-the-board slowing down. The pieces are usually brilliantly colored and densely layered visually, and elements shift very slowly within the frame.

Parenthetically, it should be noted that this slow pace is not limited to center work. The artists there participated in a trend that had been developing since the late 1960's in the "time arts." A slow pace was creeping into works by very different artists, from the black-and-white, hour-long tapes of T-shirted Bruce Nauman pacing around his studio, to the full-color, sumptuous nature tapes by Bill Gwin. In most of these tapes a set pattern is established that is repeated for a very long time. Typically, the viewer is at first preoccupied with figuring out what is happening, then slowly his attention becomes focused on his own reactions, on his own thoughts. Often viewers become bored and restless as the pieces seem to persist interminably. But sometimes the overall reaction is one of relief, of depressurization from the fast pace and jam-packed imagery of much film and TV of the mid-sixties. This slow pace is a phenomenon quite particular to the late sixties and early seventies (several artists, from Nauman to Woody and Steina Vasulka, mentioned the influence of musicians like La Monte Young, one doesn't see so much of it anymore, but at the time it was valuable, and it had a way of helping people look at moving images with fresh eyes.

At any rate, given the shared slow pace, tapes made at the center explored different kinds of ideas. Don Hallock worked with very structured feedback, shifting his images slowly until the viewer lost a normal sense of vertical orientation vis-à-vis the image. Willard Rosenquist and Bill Roarty worked with incredibly subtle patterns of light, turning the monitor surface into a diaphanous sculptural space. Bill Roarty in later tapes has used similar lighting on the human form, in this case the mime dancer Noel Parenti. These tapes work in a fascinating border area between representational and nonrepresentational imagery: the monitor seems to contain only shafts of colored light until the figure shifts slightly and a contour of Parenti's body seems discernible.

A similar border area was explored by Bill Gwin and Warner Jepson in *Irving Bridge*. There is only one camera shot of a woods scene with a bridge. It begins "straight": you can recognize the scene and

hear natural "woods" sounds. Very slowly both the visuals and the sound are altered electronically so that in the midst of the tape one is seeing an electronically colored equivalent of the woods and hearing electronic equivalents of bird sounds. Then just as slowly it changes back again. The tape was meant to be played on a loop so that the sonata-like three-part development of its structure would not be a pat thing; the scene would shift back and forth, from one kind of landscape to another.

Stephen Beck's work stands a little aside from the rest of the center's. BECK —



FRAME 065 step through next 17 frames

built a non optical synthesizer at the center; this tool is different from the Paik-Abe synthesizer in that it need not use cameras. The imagery is all generated electronically. In some ways, Beck's work is the most traditional of the abstract color video artists. He takes painstaking care with the structure of his works—they tend to be short, precise, and rich with references—just as he was methodical about his choices when building his synthesizer. This structured approach to abstract art is not new in this century. Beck speaks of his respect for Kandinsky:

*He's really the painter who has influenced my own thinking the most. I think this ties my video into a tradition within the arts . . . the non-objective tradition. On the Spiritual in Art [a book written by Kandinsky] is really a masterpiece of someone putting down in words what the experience is about. . . . I had experiences of seeing the visual field break down into elements, and when I was doing the design for the synthesizer, I structured these elements: color, shape, texture, and motion. And I further took the element of shape into sub-categories of point, line, plane, and illusion of space. I later read Kandinsky's work and I found it was really close: I had no foreknowledge of his work when I arrived at the same, or a very similar scheme. I was astounded. I was reading his notes for his class at the Bauhaus and there it was, the very same analysis.*

Many of Beck's works take as a theme a central idea; he structures the work from inside out to make that idea visually manifest. One piece was *Conception*; another, done in collaboration with filmmaker Jordan



STEP BACK



STEP FORWARD



INFO frame 7424 to 10544

Belson, was called *Cycles*. This last work deals with layers and layers of cyclic images, organized into a cyclic structure:

*The point is, the cycle is, again, a phenomenon without magnitude; there are small cycles and there are big cycles. This work involved a lot of study of the phenomenon of cycles, and in as much as they were studied and understood, their concepts were embodied visually and dynamically, and incorporated into the work. The only word in the work is the title, "cycles." Everything else about the concept is expressed in the visual language.*

Some of Beck's most interesting works manage to present to a wider audience ideas normally available only to specialists. He likes to use scientific and mathematical imagery because he feels it's part of our times. This interest may come from his own electronics background:

*. . . what about the circuit designer, the circuit builder as the real electronic artist . . . as opposed to people who are expressing more traditional concepts with video, with electronic imagery? What about the guys who are actually building the instruments, designing the circuitry? Is the circuitry not capable of being recognized as being a real accomplishment and achievement in and of itself? An aesthetics that the average man has no inkling of other than, "Wow! It's a lot of wires and switches and knobs."*

His latest patterns, which he calls "VIDEO WEAVING," —



FRAME 83 step through next 1 frame

are based on ideas from a time when artists used mathematics as subject matter:

*It comes from the magic squares devised by Arabian thinkers of the sixth and seventh centuries, when they mastered algebra and applied algebra to their art. The religion of Islam forbids any representational image. It's a totally different concept of visual expression than what we have; you're just not permitted to portray an object of creation. It's largely based on portraying what we would call mathematical harmonies. Their wonderful arabesques and domes and patterns are all manifestations of mathematics, which*

*in our day and age we would find in some equation in a book, which perhaps makes it less vivid, and less important to many people. People ask me sometimes, "Is this mathematical? How does this relate to mathematics?" And I say, "It is mathematics, just like music is mathematics." You have implicit structures of harmonies and ratios. Instead of music, where there is vibration of air, here it's the vibration of light, with different colors and patterns. You don't have to relate to it as a drab mathematical theorem or equation. It takes on a much more vivid presence.*

Warner Jepson was the composer for the center after 1972; at first, he worked closely with the artists, putting sound to their tapes, but he has been experimenting all along with images of his own as well. Most of his imagery is generated by audio equipment that has been connected to the video gear. He talks about his latest work:

*. . . I've been doing some things sending an audio signal into a machine we have at the Center called a mixer, a colorizer, and a keyer. It takes audio signals from the oscillator inside the audio synthesizer and changes them into bands of various widths and expansion on the screen and puts color in, so the color gets mixed in gorgeous arrays. I've even begun to use the camera and to mix audio created images with camera images. The audio things will go right through the camera images and make strange new colors.*

His idea is to make a work that is totally integrated aurally and visually. He feels the two should complement each other completely. The problem is to balance the work so that both visuals and audio are interesting. He explains:

*In a lot of these experiments, I'm not even putting the sound on because the sound is dumb. The thing about sound is, it's so complex that when it's represented in images, the images are so complex, they become chaos. Whereas the simplest sounds make the clearest images. . . . There's a lot of activity in sounds and it becomes blurry visually; it looks like noise. So the simplest sounds, like single tones, make the best images . . . working with sounds you actually want to use and save is a problem.*

Jepson explains the reasons he is looking for direct relationships between sound and image. Many



STEP BACK



STEP FORWARD



INFO frame 10559 to 11299

video and film artists make the visual part of their work, and then set it to traditional music to give it structure:

*Even going back to the 1920's, the abstract films that were made then relied on sound for their form. Even Walt Disney's Fantasia. Music has always been a moving art, and visuals had always been static, so when visuals got to moving, they needed that form that musicians have solved-it gives support to the visual artists. It's time for visual artists to find their own moving form, pacing, and development, and figure out what they need to do to make an existing work without sound, or with sound, but on its own terms.*

One of the few times the work of the center was exhibited in the San Francisco community was when Don Hallock built his "Videola" for an exhibition at the San Francisco Museum of Art in the summer of 1973. The *Videola* was a construction that expanded the image from one television monitor so that a large audience could watch it. It was essentially a wooden pyramid laid on its side so that it looked like a huge megaphone opening out toward the audience. At the back, at the apex of the pyramid, was a television monitor. The insides of the pyramid were lined with mirrors, so that the image on the monitor was made kaleidoscopic. However, the facets of the image didn't go off at straight angles; the image bent and became a circle, so that facets seemed to form a sphere. For performances, all the lights in the rooms were turned off and the outer frame of the pyramid was masked with black. The audience could look in and see what appeared to be a huge sphere of shifting, dissolving, luminous colors, suspended in dark space. It was especially successful because it expressed the video images in dematerialized, almost nonphysical terms. Nam June Paik has explained the difference between kinetic art and video art as the difference between machines and electronics; one uses objects obviously controlled by gravity and the other does not. But the potentially weightless quality of the video image is often altered by its presentation as a small image in a piece of furniture in a lit room. The *Videola* device allowed the image to float. "*Videola*" was a very successful exhibition: two hundred people could watch it at one time, and Hallock estimates that 24,000 people in all saw the show.

The center's method of operation was to limit the number of people working there so that those people could work very freely and constantly, learning gradually, as new equipment was built and acquired, how to build new patterns of images. This meant that very few people had access to the equipment. Since practically no individual has the means to own such equipment personally, other artists in the Bay area turned to small format, portable black-and-white equipment. As if to fill the vacuum, another center appeared to support this kind of video.

The director of the de Saisset Art Gallery at the University of Santa Clara is Lydia Modi Vitale, who is very interested in exhibiting many forms of avant-garde art. In the winter of 1971-1972, she hired George Bolling as video curator at the de Saisset, and gradually the gallery became the steadiest center of conceptual video in the Bay area. There was a flourishing conceptual art scene in San Francisco at that time, and Bolling introduced several of the artists to video, and even did the video for many of their early tapes. The four most consistent workers in the medium have been Howard Fried, Joel Glassman, Terry Fox, and Paul Kos. Bolling has held a constant stream of exhibitions of video from all over the country. Where David Ross's strength is to organize large, democratic exhibitions that give exposure to a large number of works, Bolling's is to be critically selective, organizing one-person or small-group shows.

Howard Fried's work is intriguing and rather unique in the conceptual video world. His tapes are carefully structured performances, which have gotten more and more complex with time. In his early tapes, Fried himself is the protagonist, and during the course of the work pits himself against some social structure, trying to figure out a way of proceeding. An example is *Sea Sell Sea Sick at Saw Sea Soar*, a forty-minute black-and-white tape done in 1971. Fried is seated at a table, trying to run the gauntlet of choices while ordering in a restaurant. He keeps answering the waiter's questions with more questions "What kind of pie do you have?" . . . "What is the difference between Big Burgers and Jumbo Burgers?" . . . "You don't have Coke?" until the waiter becomes annoyed and asks another to take the order. Fried exasperates this waiter as well, and the two waiters begin to take turns trying to get the order. This goes on interminably. The table with

Fried is on a swing parallel to the camera, as are the two waiters. The camera itself is on a third swing so that the action in the image is as persistently shifting and inconclusive as the action in the performance. Gradually, the scene comes to have broader implications; Fried seems like the battered victim of a ceaseless interrogation. His defense is to be passive, to not order, and it finally works: one of the waiters quits in disgust, and one of the variables of a situation that seems to be nothing but variables is eliminated.

Fried has a startling ability to choose single situations that seem to hold implicitly many issues of institutional and individual sanity; at base, he is examining the role decision-making procedures play in structuring sanity.

Joel Glassman has developed a very different style. He began on the East Coast—he did both light sculpture and sequences of photographs. His latest tape, *Dreams*, is a collage of images that is somewhat similar to tapes being made at the present time by a few other people in the country. The early conceptual tapes that explored specific aspects of perception have given way in some cases to an interest in how one perceives through time, how one builds up memories. At one end of this group of artists is the information-collage work of Ira Schneider; at the other end are the intensely personal tapes of Lisa Steele and Colin Campbell in Toronto. Glassman's tape is somewhere in between. We are shown a series of images that seem to belong to one man's experience—the walls of a particular room, clouds, particular bits of landscape, written notes. Some of the images are persistent and seem to have special power or significance, as do certain images in a dream. Scenes reappear again and again, altered slightly by what came before them, and altered as well by what one hears as one sees them. Glassman takes painstaking care with the sound and is very aware that what we hear shapes what we read into a scene; seemingly innocent scenes can send shivers down your spine when you hear manic laughter, sobs, whispers in the background.

Glassman shows that video tape can be used to provide a metaphor for one's consciousness. Images can be strung along through time, paralleling the mind's ability to recall images. Actual events and actions are not recalled in a pure or neutral state but up through the swirl of images existing in the mind, colored by what one was thinking of earlier.

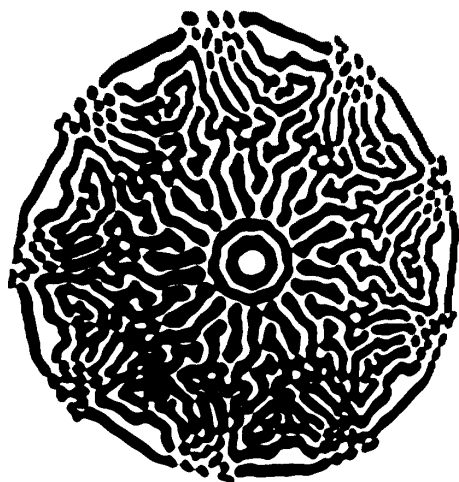

Feedback by Skip Sweeney

In addition to these two centers, NCET and the de Saisset, there were other activities going on in the Bay area as well. TVTV had its headquarters in San Francisco for a few years, and an excellent documentary group, Optic Nerve, exists there today, as well as Ant Farm, a media group that has made many tapes and held exhibitions. Still another group, VIDEO FREE AMERICA, —



FRAME 184 step through next 5 frames

was co-founded by SKIP SWEENEY —



FRAME 190 step through next 5 frames

and Arthur Ginsburg. They have made documentary video tapes, mounted elaborate gallery installations, innovated ways of using video with live theater, and held regularly scheduled viewings of tapes. They were more directly and actively part of the video counterculture of the late 1960's and early 1970's than was either the center or the de Saisset, but it would be wrong to say they were more interested in politics than art. They used what was at first very limited equipment and created very beautiful video. Sweeney, for example, through hours and hours of tinkering with knobs, became one of the handful of people to master feedback.

A note about FEEDBACK: —



NANO C 11731 to 18452



STEP FORWARD



STEP BACK



there are many, many feedback tapes. Almost every artist went through a period of doing feedback, if only because it is one of the simplest ways to create powerfully lyrical, abstract imagery given only a camera and a monitor. It is pure video: the camera is turned to pick up the image on the face of the monitor that is displaying that camera's image. A closed circuit has been established, so what you get is an image of a monitor within a monitor, and so on, an infinitely repeating image. By tilting the camera and by altering the controls for brightness, etc., abstract patterns are formed. There are so many variables in the image that it is very difficult to control; the picture constantly "spins out." A very characteristic feedback image is of a vortex, an electronic whirlpool. In practiced hands, such as Sweeney's, this can become a shimmering, interweaving mandala.

### Seattle

Seattle should serve as an example to bigger art centers: sometimes the smaller places can do things better. There is a group of people there who are not associated in a formal way—Anne Focke runs an art gallery, Ron Ciro and Cliff Hillhouse work for the local public television station KCTS-TV, and Bill Ritchie is a professor at the University of Washington—but who share an interest in video, keep in touch with each other, and make things happen. They work on a modest scale, not supported by huge institutions or grants, but they persevere and make, or help make possible, marvelous tapes.

Anne Focke used to work for the Seattle Art Museum and found herself producing shows about art for local TV. Two years ago, she broke away and established an independent, nonprofit art gallery called "and/or." As the gallery's name suggests, Focke has a pluralist, open approach to contemporary art and shows a wide variety of work. She has, however, been especially interested in video. She has helped artists get time to use the KCTS studios and has shown both locally known and nationally famous video artists in her gallery.

At KCTS, Ron Ciro has worked with Anne Focke to get artists into the studio. He has also encouraged Cliff Hillhouse, a station engineer, to work on his own video quantizer/colorizer. Ciro and Hillhouse both visited the National Center in San Francisco as part of its internship program, and are now excited

about experimenting with video imagery. KCTS-TV's equipment is black-and-white, but Ciro and Hillhouse are eager to work in color. Cliff works during his off-hours building new equipment based on circuit designs the National Center gave him. He makes one think the shy garage inventor, who works unsupported by massive research and development money, is still alive and well in America, even today. His only problem is finding money to visit other engineers designing new video equipment so they won't duplicate each other's work.

Bill Ritchie is a professor of fine arts at the University of Washington. He teaches print making most of the time, and video part of the time. He is very widely read and interested in how video fits into the history of art in general and print making in particular. He has done one of the two or three best feedback tapes in the movement. It is "seeded" feedback; that is, it is based on an outside image, in this case that of a print Ritchie did called *My Father's Farm*. In a feedback setup, the image turns into very rich, streaming colors. Ritchie's friend Carl Chew put his hand in front of the monitor, so in the final tape it looks as if his hands are forming and modeling the flow of colors: the tape is called *The Hands of Carl Chew on "My Father's Farm."* Feedback is made by people, but rarely does a human form seem to have any part in it visually: in this tape it achieves a wonderful mix.

### Dallas

Dallas is the location of one of the three major satellite centers set up by the National Center. (The other two are at Southern Illinois University, directed by Jon Moorman, and the Rhode Island School of Design, directed by Bob Jungels.) It is run by David Dowe and Jerry Hunt. Dowe was a director at the public television station in Dallas when he went to the National Center to be in its internship program. He went back to Dallas excited about experimental television; for a while he conducted workshops both at Channel 13 and Southern Methodist University, but eventually he shifted the whole operation to SMU. Jerry Hunt's field is music, and he has set up an electronic music studio/workshop alongside Dowe's video studio at SMU. The two men build their own equipment and are constantly elaborating upon, improving and re-synthesizing their machines. Some of their most exciting work

has been done in performance, playing their audio and video synthesizers together. They have given concerts in the U.S. and Canada, and have made a European tour as well.

It is obvious that both men share a rare set of talents; not only are they involved in pioneering technical work, but they are also capable of explaining what they have done—they are born teachers. In addition to a masterful, darkly symbolic tape, *Procession*, they produced a lighthearted *Electronic Notebook* tape for the National Center, which explains in a marvelously clear way what feedback is.

### Minneapolis

Jim Byrne was just out of art school when he attended a National Videotape Festival Workshop held at the Minneapolis College of Art and Design. He says he had been at loose ends, depressed by all the "bad art" he saw being produced. The teachers at the workshop included Peter Campus, and Byrne was immediately impressed by his work. He became Campus's student and worked with him for a year and a half; he is working independently now. In a sense, he is in a second generation of video artists.

His work reminds one of Campus's in that he does both installations and tapes, and his tapes are concise statements often made using one special effect obtainable only in video. One of the tapes Byrne produced in 1974, *Tangent*, is typical. To start, he has prerecorded an image of himself moving about a space. Sometimes he comes up close to the camera and stares out so that one sees only his head; sometimes he walks back and stands against a far wall. In *Tangent*, Byrne plays this tape on a monitor, then tapes himself picking up the monitor and reacting to the image, comparing his space to the image of himself in the space on the monitor. Sometimes he holds the monitor up to the camera so the frame matches the frame of "our" monitor: it looks as if the prerecorded image is playing directly on our monitor. Then he twists the monitor back so only one side of it coincides with our monitor. The space both inside and outside our monitor seems to warp. What Byrne has done is create a set of powerful illusions that make our space seem to meet tangentially with the spaces in the monitor. Watching the tape changes the way you think about the illusion of the TV image. By presenting us with such a clear, real space and person, himself, Byrne

has opened a door—he has allowed us to compare our own environment with that on a television monitor and so has displayed its illusion to us.

Byrne works alone in Minneapolis and some of his work has been shown at the Walker Art Center there. There is an excellent video access center in Minneapolis, the University Community Video Center at the University of Minnesota. They have one-half-inch video tape equipment, both for recording and editing, and Byrne did his first work on their equipment.

### Halifax

The Nova Scotia College of Art and Design in Halifax is run by Garry Neill Kennedy, an art internationalist. He invites artists from many places to come to NSCAD to teach, and consequently the school combines a beautiful seaport location with a cosmopolitan teaching program. The school has very modest video equipment, all black and white, some portapak, and the idea has been to conduct a purposeful investigation of the medium. A review of tapes made at the school since 1970 is a mini-review of the general course conceptual art has taken over the past five years.

The first tapes done, in Pat Kelly's teaching classes, are very straightforward explorations of the medium, with members of the class trying out different ways of filling the monitor's space with their bodies. Soon the tapes reveal a search for a way to structure time and events, and this often takes the form of counting or repeating so the structure is as self-evident as possible. Some tapes examine more specific problems, like sound-image relationships.

For example, in David Askevold's *Fill*, the artist wraps pieces of foil around a microphone head; as the image (the silver ball of foil) increases, the sound (the rustle of foil on the mike) becomes muffled and decreases. As he removes the pieces of foil one by one, the process is reversed.

A second series of tapes, done since 1974, are cleaner, tighter, more polished products based on the early explorations. An example is Lauren Butler's *Untitled*. We see bare feet walking around on white paper. The person is carrying a bucket filled with dark liquid; from time to time the person puts his/her feet into the bucket to dye them, so the feet leave tracks on the paper. We can only see the pacing feet

and footprints we can't see the edges of the paper. Finally, the person walks off the paper, the camera zooms back, and we see the footprints spell out "one step at a time"

The most recent tapes indicate a new, more personal direction. *One*, by Dede Bazyck, was in the "Southland Video Anthology." It is a surreal journal, a collection of vivid little impressions and actions strung together through time by the artist.

### Toronto

Another center for video activity in Canada is in Toronto. It is focused around two organizations in the city. The first is a group of three artists, Michael Tims, Ron Gabe, and Joree Saia, who call themselves General Idea. They are engaged in many activities, but most of them center around locating and restaging contemporary rituals. For example, from 1968 to 1971, they staged annual Miss General Idea pageants based on the ritual of Miss Anything beauty pageants, and managed to embroider an elaborate statement about the contemporary iconography of glamour. They are now involved in a complicated campaign of maneuvers and preparations for their biggest event, the Miss General Idea pageant of 1984. They first used video in 1970 to document that year's pageant and have continued to use it off and on. They have worked a great deal with mirrors and made an exquisite tape in 1970 called *Double-Mirror Video*. Two mirrors are set up opposite each other at the water's edge on a lakeshore. The mirrors are tilted, creating infinite echoes of reflections (a pure example of nonelectronic feedback). The camera zooms slowly in and out of the mirror images; one is never sure how deep inside the illusion one is until the very end, when the camera draws back from the mirror reflection altogether. It is a short, perfectly crafted work that capitalizes on the seeming transparency and clarity of water, mirrors, and light to disorient the viewer.

One member of the group, Michael Tims, has also organized a media distribution system called Art Metropole. They have a highly selective catalogue listing an excellent group of books, films, and video tapes. Their video tape distribution is handled by Peggy Gale, who was until recently the head of video funding for the Canada Council.

Another center in Toronto is A Space, an art gallery that supports video and has a library of

tapes. Parked under the gallery is a van with a studio color camera and editing equipment; this van provides access to equipment for local artists. One person who uses the equipment is Terry McGlade, who works mostly with dance. He has made a wide variety of interesting tapes exploring all kinds of dance-videospace relationships.

In addition, Toronto is becoming a center for a newly emerging kind of video. Bits of it exist elsewhere—in some of the tapes from the "Southland Video Anthology," in Joel Glassman's work in San Francisco, and in some tapes made in the last year or two in New York City. In Toronto, two artists in particular, Lisa Steele and Colin Campbell, have concentrated on it. All these artists share a concern with finding ways of structuring autobiographical material in new nonnarrative ways. In Steele's and Campbell's work, recent tapes string together a series of images, or quiet events. Often the artist appears as the sole person in the tapes; almost always one hears his or her voice, telling you the "story." Often there are recurring images, ones that seem to have a special hold on the artist's mind.

Lisa Steele puts her objectives clearly:

*I got sick of people portraying dreams as foggy dry-ice-and-water type scenes. Dreams aren't like that. They are crystal clear. They just seem to follow a logic of their own. I'm trying to reconstruct that logic in my tapes.*

This is reminiscent of Glassman's recent tape, *Dreams*, but hers are even more directly personal, since the artist often looks directly out at the viewer.

Campbell and Steele base their tapes on everyday visual reality. Nothing at all extraordinary is put in front of the camera physically. Campbell shows us the view from his window, Steele examines her plant collection. It is the means of showing these things, the order and way in which we are asked to perceive them that is extraordinary. It reminds one of Analytic Cubism: Picasso and Braque were also interested in perception itself, in how people take in information. However, the means of depicting this, the new techniques, is so strange to look at at first that there was the danger people wouldn't be able to "read" the paintings at all. Therefore, the painters used as a foil for their new mode recognizable everyday content—guitars, coffee cups, wineglasses, people. Much of the fascination of these paintings

comes from the tension between what you can recognize and what is new to you.

Some of the new video tapes do the same thing, albeit in different ways. Campbell's and Steele's work shows you everyday physical reality in new sequences; they are using both the camera's ability to record our daily living environment and its ability to structure this information through time to construct new modes of perception.

### New York State

Owing largely to support from the New York State Council for the Arts, New York State has the most energetic and diverse range of video activities of any area in this country or Canada. Most of the activity started in the early years of the video movement in New York City. Over the years, people left the city for smaller communities and set up small groups and organizations, each with its own perspective.

THE CENTER FOR EXPERIMENTAL TELEVISION —



FRAME 106 step through next 39 frames

is in Binghamton. It exists completely independently of SUNY, but a professor from the university, Ralph Hocking, runs it. He is assisted by Sherry Miller and R and D persons Don McArthur and David Jones. It is an access center—anyone can come in and check out equipment to make any kind of tape. One of Hocking's main interests, however, is for processed color imagery, and he has done all he can to encourage that kind of video at the center. Nam June Paik was the first artist-in-residence, and he built his second synthesizer there. Lately, the current artist-in-residence, Walter Wright, who comes from a computer background, has been working with Hocking to design new equipment and build up an image bank. This bank is a collection of black-and-white tapes that have been processed in increasingly sophisticated ways; the resulting images have truly amazing colors and solarized effects. It is interesting to note that the image bank material is not purely abstract. Wright feels that computer generated art is often dull. He says viewers can intuitively complete the whole pattern after having seen only a tiny portion, and watching it work itself out becomes boring. Wright's basic black-and-white footage is of "natural" imagery, moving water being an example. The movement is rhythmic and has a

certain regularity, but since in nature there are so many variables causing motion, it paradoxically also seems to have a random element, and so holds surprise. One of the most intriguing things about watching these images is that most of one's ability to recognize the base image through all the color and special effects is dependent upon its movement; one can always recognize rippling water, whereas a still frame from the tape would be illegible, abstract. Wright has traveled around the state, giving synthesizer performances.

A second focus of activity in the state has been Syracuse. The Everson Museum has had an amazing number of exhibitions of many different kinds of video art, first under the direction of David Ross and now under Richard Simmons. Many artists have had first one-person shows there. All in all, it has been the consistently best place on the East Coast to see new video art. Also in Syracuse is Synapse, a very posh, well-equipped cable system at the university. Students there have received excellent technical training. One of them, John Trayna, is now the technician at Electronic Arts Intermix in New York City; another, Bill Viola, is running Art Tapes 22 in Florence, Italy.

Woodstock Community Video is directed by Ken Marsh. He was an original member of People's Video Theatre, an early video group in New York City. In Woodstock, he has been committed to getting alternate material on cable TV. An independent, non-institutional group named Media Bus live in Lanesville, New York. Their roots are also in the city; as the Videofreex, they were one of the first groups to form. They moved to Lanesville to see if they could establish a genuinely alternative television system for a small community, and they have largely succeeded. They have a regular Saturday-night show, for and about the community. The membership of the group is diverse—they do all kinds of work, from local reporting to video games, and members of the group do individual creative work as well.

One of the best "documentary" tapes was made by Nancy Cain of Media Bus. It is a very short piece titled *Harriet*. It shows Harriet, a Lanesville woman, at home, taking care of her children, making beds, fixing meals. Her life seems made up of rather dull work, but she is a very spirited and lively person. At the end of the tape, she acts out a fantasy for the camera: she packs her bag, screams she's fed up with Lanesville, jumps in the car and takes off down the road, laughing uproariously, radio blaring. It



STEP BACK



STEP FORWARD

was a marvelous documentary of the type professional documentary groups are only talking about—a mixture of fiction, nonfiction, everyday routine and fantasy, all of which adds up to a most sensitive portrait.

In recent years, Buffalo has become a small think-tank for studies in media. This is largely due to the energy, enthusiasm, and ambition of GERALD O'GRADY, —



FRAME 158

who has set up the Media Study Center, an independent department within SUNY at Buffalo. He has assembled a faculty that includes some of the most interesting people working in film and video today—Paul Sharits and Hollis Frampton in film, and WOODY AND STEINA VASULKA —



FRAME 223 step through next 5 frames

in video. O'Grady has a constant schedule of workshops and conferences, lectures and viewings. He is interested in all aspects of media, from each individual work to the role all the mass media play in our society.

The Vasulkas are probably among the most thoughtful, intelligent people working in video, and their work is central to the basic concerns of the medium. Steina is a violinist from Iceland and Woody is a film-maker from Czechoslovakia; both have been interested in electronic arts of all kinds for a long time. They lived for several years in New York City where they set up THE KITCHEN,



FRAME 208 step through next 1 frame

a kind of free-form gallery and electronic-arts performance center, in the summer of 1971, and showed much early video there as well as helping to organize some of the first video tape festivals.

Woody remembers how they felt when they first began to use video:

*Our context was not really artistic when we started to work with video. It was very far from what I would recognize as art. . . . There are various motives for people who stumble into video. In some cases, it was pure accident; in some cases, it was hope. In my case, I had been in things I couldn't work with. I was in film, and I couldn't do anything with it. It was*



The Kitchen, 1972

*absolutely a closed medium to me. I was educated in film at a film school. I was exposed to all the narrative structures of film, but they weren't real to me and I couldn't understand what independent film was. I was totally locked into this inability to cope with the medium I was trained in. So for me, video represented being able to disregard all that and find new material which had no esthetic content or context. When I first saw video feedback, I knew I had seen the cave fire. It had nothing to do with anything, just a perpetuation of some kind of energy . . .*

The Vasulkas have done both “documentary” and “abstract” video over the years: this discussion will cover only the latter. They stuck to their guns—there is no dramatic structure in their work; the tapes have fast-moving rhythms, but shifts occur according to permutations in the way the image is structured, not according to any dramatic plan. Their early work pursued two themes, according to Steina:

*We approached the art material, meaning that we dealt with voltages and frequencies. We are dealing with the signal, that is the audio signal and the video signal. . . .*

*Woody: What was really, truly significant to us at that time was something nobody really detected. That was to make pictures by audio frequencies, and to get audio frequencies out of pictures.*

The first tool the Vasulkas got was a portapak; the second was an audio synthesizer. They hooked the two up and sometimes could use the audio signal to generate video images, and sometimes use the video signal to generate sounds.



STEP BACK



STEP FORWARD

Steina: *That was the first approach we had. Secondly, another characteristic of our work has been a consistent traveling of the frame, horizontal traveling.*

Much abstract video imagery has the tendency to move vertically. The Vasulkas insisted on moving theirs horizontally, often along lines of monitors so it looked as if the image was traveling down the line from one monitor to the next. Woody explains:

*At that time I was totally obsessed with this idea that there was no single frame anymore. I come from the movies, where the frame was extremely rigid, and I understood that electronic material has no limitation within its existence. It only has limitation when it reaches the screen because the screen itself is a rigid time structure. But the electro-magnetic spectrum itself exists, organized or unorganized, totally in space. Confining it in a single monitor is like a view through a camera, or a single projection frame. All this gave us the idea that there was no truly rigid frame, just particular organizations of time and energy. The image is fed into a sound synthesizer . . . the organizational mark itself is electronic. That's what we in video call horizontal and vertical pulse—it paces the image. These are the sync marks which are usually hidden behind the frame. It's all on the images, just as film has sprocket holes which are normally hidden. Electronically, there are also frames. What this does is disregard the reference of being locked into a single frame. It travels; there are two time layers. One is static, and the other is dynamic and all this is exposed. . . .*

All this means that one is often watching a horizontally drifting image, and that the sound and the image are directly related in some way. The total effect is of a totally integrated work that is nevertheless dynamic, always energetic, always moving.

The Vasulkas' work has tended to evolve with their equipment. Woody says:

*Our work is a dialogue between the tool and the image, so we would not preconceive an image, separately make a conscious model of it, and then try to match it, as other people do. We would rather make a tool and dialogue with it; that's how we belong with the family of people who would find images like found objects. But it is more complex, because we*

*sometimes design the tools, and so do conceptual work as well.*

During the years 1972-1973, they went through a surrealist period. They had been going through picture books of Magritte's work, figuring out how natural it would be to do some of his works with video special effects. One work, *The Golden Voyage*, is directly based on Magritte's painting *The Golden Legend*—a loaf of bread travels like a finger, opening up certain areas of the image to special effects. Even in these works, where there is no horizontal drift, there are at least two kinds of motion going on in each image; motion, rates of change, are always present in their work.

Their latest work involves raster manipulation; each line of the video image becomes a carrier of energy through time. Sometimes the images are sketches of simple wave patterns. Sometimes a portapak tape of a street scene is used, and the raster is altered according to the brightness or energy in the image. So what one is seeing is a topographical map of the brightness of an image; where the image is bright, it lifts the lines; where it is black, they fall. The Vasulkas call this recoding, and indeed it does make one recode the way the image is looked at because new kinds of information are being given.

Woody explains what he is attempting to do with this new imagery, which can look quite stark and unaesthetic, because it is so new:

*You should be precise about your pleasures, and communicate those to the audience, rather than those which are widely shared. That's what I have against any dramatic structures. They already appeal to an experience which is built through the centuries. . . . I walk somewhere, and I see something which is art, and I agree with it. But then I question it. I say "Why did I like this? Because it is art?" And then after all, I feel frustrated that I really enjoyed it, because there were other qualities that were missing. . . . Right now I am interested in knowing, in knowledge, than in the esthetic end of it. So then I must say, "Did it say anything towards my own process?" And often I have to say it didn't, it just extended what is called art, in its beauty, or its accomplishments, but it didn't say anything to my personal problems. Sometimes when I watch people's work, I tend to underestimate it because it's not*

*beautiful. But then I have to re-evaluate it and change my preference, because in the long run, that work which was not so beautiful, might have been more important. . . .*

*Basically art provides a continuous stream of models of consciousness. There are always certain historical periods when new consciousness is created, for example, when Freud reached a new understanding of the relationship between people. Eventually there is a construct of consciousness which has art as a model. . . . Now, what I am interested in is if there is the possibility of actual, total redesign of consciousness in the sense of its model. During the early part of my life, I was looking into myself for an alternate model of consciousness, and I didn't find it. Now turning more and more towards material, I'm trying to find this new model of consciousness within the material. . . .*

*Since we look at reality mostly through our eyes, the reality has total dependence on perception, on how images are formed in the eye. . . . But through an electronically-generated image, I found non-lens, non-eye possibilities of restructuring the image. . . . I am not totally dependent on reality as we know it through the lens or eye. . . . Through electronics, I think there is a way of interacting with real models, with models taken from nature, and a new concept of nature can be synthesized.*

*. . . The closest thing to all this is radio astronomy. The universe as we knew it until now was constructed on information of light, which reached our eyes and provided a model of the conscious universe. But now, with radio astronomy, we are getting a very different notion of our universe. First of all, we receive information which is not visible. It's not points or spheres anymore. It's energy which is not in a permanent state; it is permutating, as a matter of fact, all the time. So that suddenly, through the instruments we have, we are reconstructing the universe in some visual sense, because eventually we translate radio waves into some visual model. We are now trying to visualize space which exists only as electro-magnetic forces. . . . It's the notion of the organization of energy in time that for me is the key to all sorts of changes within life.*

## **New York City**

New York City has continued to be the single most productive place in the video art world. There are several places people can watch tapes and see installations: Castelli-Sonnabend, Electronic Arts Intermix, The Kitchen, and at Anthology Film Archives, the video part of which is directed by video artist Shigeo Kubota, to mention only a few of the most prominent. Some artists can work at the TV Lab; independent artists can now find access centers for equipment and editing facilities. There are frequently exhibitions, as well as new books and articles. A discussion of the work of three artists, Ira Schneider, Peter Campus, and Bill Gwin, may serve to indicate in a modest way the richness and diversity of work being produced.

Ira Schneider's work has been as central to the medium as that of the Vasulkas. He was present during the very earliest months of the movement, and seems to have been a founding member of most of the original groups. Together with Frank Gillette, he did one of the earliest multimonitor installations, *Wipe Cycle*, at the "Television as a Creative Medium" exhibition held at Howard Wise's gallery in 1969. It was a nine-monitor piece, a console of monitors three high and three wide. Images shuttled from monitor to monitor, following four separate programmed cycles; there were live and delayed images of the gallery itself, broadcast images, prerecorded tapes, and gray "light" pulses.

This mix of images, which Schneider calls "information collage," has remained central to his work. In the spring of 1974, he did an installation at both the Everson Museum and The Kitchen called *Manhattan Is an Island*. Twenty-four monitors were arranged in the shape of Manhattan Island. The outside ring of monitors showed tapes of images of the island from boats; bus, land, architecture, and people tapes were all played on monitors in a logical part of the "island." The monitors were arranged at different heights, following the topography of the island. One monitor, facing up, displayed tape taken from a helicopter. Viewers could move in amongst the monitors, seeing specific bits and views of cityscape, or stand outside and watch the whole island hum along. The tapes from this piece have been edited down into a single tape one can watch on a single monitor.

Schneider says he tries to establish conditions with the information he provides, and so "guide not

push" an audience along a route of perception. His latest tape, *Bits, Chunks, and Pieces*, does precisely that. So far, it is a black-and-white fifty-four minute "video album." It is very clearly and elegantly taped and moves the viewer along through different kinds of American landscape. One goes from "Santa Fe Fiesta" to "Tex-Mex" to "Rock 1," zooming along looking out a car window, stopping to see an eighty-five-foot doll named Zozobra explode in fireworks at the fiesta. Toward the end, the pace quickens, one becomes aware that the sound doesn't necessarily match the image, and certain sequences are repeated over and over (one remembers especially a line of cows swinging along the side of a road while "Put on Your High-Heeled Sneakers" blares on the car radio). Schneider stresses the nonnarrative nature of his album; he wants each viewer to figure out the information by himself.

Peter Campus was in the film business for several years. From about 1966 to 1970 he underwent a gradual change, disentangling himself from film: eventually he made the decision to become an artist and began to do work in video. His work takes two forms—he does both tapes and gallery installations. The tapes typically use some visual effect special to video, chroma-key or two camera images superimposed, to set up a shift in perception. His two best-known works, *Three Transitions* and *Set of Coincidence*, each have three parts, and each one builds quietly on the statement made by the previous part, from concrete to abstract, from witty to somber.

One sees the image of Campus himself in the tapes; the installations are triggered by the viewer, who usually deals with an image of himself. Generally, there is a darkened room that holds a camera and a video projector. The viewer walks in; his image is picked up by the camera and projected against a wall, usually in a way that distorts the image or makes it elusive in some way. By walking around the space, the viewer can explore the parameters of the piece—where the camera will or will not pick up his image, how his placement in the room affects the size and shape of his image on the wall, and so on.

Campus talked about his work:

*My departure from Paik, well from most people working in video, is that I'm less interested in broadcast television than I am in surveillance television. . . . I'm more interested in that kind of narrative. . . . I don't allow anyone to touch the camera; the camera is*

*always still. It really is the human stuff in opposition to the electronic stuff. They are pitted against each other. That seems to be one facet. Another facet is I'm very consciously working with transformations of energy. . . . You think of the video process: light is focused by the lens in the camera, which is photon energy, hits the vidicon tube and is translated into electrical energy, comes out on the monitor as electrons, the stream of electrons hits that phosphorous stuff and becomes light energy, photons again, is focused by the eye, hits the retina and becomes neuron energy. The relationship between all that interests me. I think with my installation pieces, one has the feeling that the wall is alive with energy. . . . And then on another level, I'm interested in the relationship between light and mass, mass being the human figure. I believe that the human figure belongs in art, and so have consciously kept it in my work. . . . I feel that when the [installation] pieces are successful, there is a parameter of behavior that is set up, and in order to fully explore the work you have to fully explore all the parameters of the piece.*

*. . . The idea is really derived from an Indian sense of temple architecture where they had very specific paths you would have to travel in order to experience the space.*

*. . . Although in my newest piece, I've eliminated even that. I'm really interested in forming an almost static image that's generated by the viewer. I'm getting to the point where I'm interested in eliminating movement, and there's just a transformation of energy. They're very intense. I'm beginning to be interested in the viewer being transfixed in some way. . . . I think my installations are more special to me because they eliminate the mind-body dichotomy, the Cartesian flaw, because you are thinking with your body in those pieces—well, not exactly; you are thinking with your mind/body. They don't make that separation.*

*My work at its worst is overloaded with content. I'm constantly working against that, trying to fit this humanity back into it. That's the way I must work. . . . I'm trying to make some kinds of information that we've always gotten from books accessible to the intuitive, experiential being.*





BILL GWIN is perhaps the most fine-arts-oriented of all the video artists. He operates firmly within the traditions of modern art and is pushing the limits of those traditions in new directions. He spends half his time painting and half making video. He says:

*These two things bear a very close relationship one to another; they feed off each other. The thrust of my work seems to switch, to alternate between the two. . . . Monet is a principal influence for my work, in particular the water lilies. I spent a year in Paris and I spent a great deal of time in the Orangerie with those paintings. It's an influence you could see in my painting I did at the same time as Irving Bridge, almost four years ago.*

Irving Bridge, discussed earlier, is one of the classic tapes done at the National Center in 1972. Soon after completing that tape and one more, *Pt. Lobos*, Gwin came to New York City, where he has lived ever since. In 1973-1974, he received one of the artist-in-residence positions at the TV Lab at WNET, and made a tape about New York City called *Sweet Verticality*. It is a visual poem, really, set to a written poem by Joe Ribar. The tape has much more motion than his earlier work; the camera pans up the length of Park Avenue, down the World Trade Center, zooms along in subways. The raw footage is 16-mm. film stock that Gwin later processed at the lab. He is a very methodical worker; he knows what he wants when he goes in to use the equipment, and each bit is carefully rehearsed. He explains why:

*With video, the medium can take over, much more easily than with painting. In the working relationship it's a much more powerful, aggressive kind of medium. Maybe you have to be a little firmer with your ideas, and be careful not to let it get out of hand, which I think happens a great deal with people's work. It's perfectly understandable. It's a hard thing to avoid. Video can be very captivating; it's easy to do up to a point, and then it becomes very difficult. But there is a certain amount of stuff that it makes all by itself, like spontaneous generation. You can sit there, and you turn one knob, and all this stuff goes on. . . . If you don't know, you can get lost inside of it. There's*

*nothing wrong with that; in fact, it's a wonderful way to learn. That's exactly the way I did learn. But you need a longer time than the two weeks the TV Lab can give you to mix a program: I did it for three years.*

From *Irving Bridge* to *Sweet Verticality* there is a marked change of intent in Gwin's work. He has been led to an interest in language, not just music or electronic sounds, but language in his visual work:

*Irving Bridge was intended to be a kind of stimulus, something that would start people's minds working in a way that was different from the way your mind normally functions. You are given a situation that asks you to redirect the way you think. But there is no effort to make any kind of precise and intelligible statement. It was only an attempt to get people to start to think, and the way they went would be totally dependent upon themselves—most people would vary considerably in their responses. I think I want to move in the direction of a more precise statement. At least I want to know if I can make that kind of precise statement if I choose to. So that I'm not always trying to get people to think, but that I'm also trying to say something. This has led me to the use of language. I guess it's one of the most central things to my thinking, both in my paintings and my video tapes. . . . That was the question *Sweet Verticality* raised. It's how to put language into what is essentially a visual form. Language is a wonderful thing, you know. There are things you can say with language you just can't say any other way. At the same time, there is something particular about the kind of responses you can elicit with visual things. And I think, if you could put those two elements together in some way that was cohesive, you would have opened up the possibility for a huge range of statements, statements of most any sort, from the most abstract, purely visual kinds, to the kinds of specific statements you can make with language.*

*Sweet Verticality* has single voices and choruses speaking the poem as readers (Gwin is careful to distinguish between readers and narrators), and printed words stream across the screen as well.

In his most recent painting, a self-portrait, phrases and bits of autobiographical information are written on the canvas, buried in the painted collage of material the way he buries his words in the

passing time of *Sweet Verticality*. In both cases, he is searching for a medium versatile enough to hold both image and language.

In this move from *Irving Bridge* to *Sweet Verticality*, Gwin marks a change that has occurred in many artists' work in video. The early fascination with the limits of the medium itself, with its ability to shape and pace time, its ability to record "natural" events as well as construct abstract ones, has shifted to an interest in using these inherent characteristics to make more specific statements. This is happening in many different ways, however, reflecting as always the flexibility and openness of the medium. As Gwin says:

*It's still a very young thing. Ten years is a short time. It's impossible to see what direction it will take... it's such an immensely flexible medium, perhaps the most flexible medium that's ever been made available. It just can do an astounding number of things, so people are doing a lot of different things with it. But that's exciting.*

The following barcodes access images which are related to the time period roughly covered by this article but not explicitly referred to:



VIDEOHEADS, AMSTERDAM  
FRAME 146 step through next 1 frame



GARY HILL  
FRAME 148 step through next 8 frames



J-P BOYER  
FRAME 157



ERNEST GUSELLA  
FRAME 178 step through next 5 frames



BEN TATTI  
FRAME 207



W. WRIGHT: Scanimat Explained  
NANO A frame 10069 to 23265



J-P BOYER: Biofeedback I  
NANO C frame 253 to 4779



J-P BOYER: Biofeedback II  
NANO C frame 4786 to 7782



P. PERLMAN: Biofeedback  
NANO C frame 7805 to 10029



P. CROWN: Biofeedback  
NANO C frame 10040 to 11713



STEP BACK



STEP FORWARD

# ELECTRONIC AUDIO / VIDEO INSTRUMENT DESCRIPTIONS

This second section of the catalog focuses upon the tools and instruments on exhibit. The barcodes in this section provide access to more in-depth examples of the origins and processes associated with each tool. Following the tools are similar descriptions of the installations which are also on exhibit. Likewise we include a list of tapes of associated artworks generated with many of the exhibited tools. These will be screened during the exhibition.

—D.D.

**FINALLY**, video inherited the world that audio had held private for so long. As soon as the hegemony of the **BIG STUDIO** began to crumble, an army of workers started pilfering the fireplace of the gods and diligently bringing it down to the people piece by piece.

More than a struggle for the new art, the effort under way was to transform the newly acquired knowledge: New language appeared, some from the tradition of art, some from mathematics and logics, some from technology. Finally, they merged into a different socio-political reasoning.

Take the word video: a latin word for seeing, a portion of a standard television signal, a small format recording system, a countercultural movement, an artform.

As in electronic music, the internal began to critique the external. From the most brilliant manifestos of Dziga Vertov, through Balasz and Bazin, the “imperial dominance of a camera” was to be questioned again.

On the surface video seemed too busy with the topics of the day, yet this particular discourse began to manifest through other, more pragmatic activity: The instrument building!

For me it was much, much more, and this is my attempt to narrate my technological wanderlust.

—Woody Vasulka

*N.B.— All the information about chronology is subject to generous doubt because it was obtained from the inventors themselves. —W.V.*



## ELECTRONIC AUDIO/VIDEO INSTRUMENT DESCRIPTIONS

- Lee Harrison Associates**      **ANIMAC (Hybrid graphic animation computer)**  
*Destroyed, documented on film*
- Don Buchla**      **BUCHLA 100 SERIES (Audio synthesizer)**  
*Collection of Michael Czajkowsky, New York City*
- Robert Moog**      **MOOG MODULAR AUDIO SYNTHESIZER**  
*Courtesy of Norman Lowrey, Professor of Music, Collection of Drew University, Madison, New Jersey  
Donated by CBS (Columbia Broadcasting System)*
- Bill Hearn**      **VIDIUM (Analog XYZ driver/sequencer)**  
*Courtesy of Steve Anderson, Physics Department, Sonoma State University, Rohnert Park, California,  
Collection of Bill Hearn*
- EMS**      **PUTNEY, MODEL VCS 3 (Audio synthesizer)**  
*Collection of the Experimental Television Center, Ltd. & The State University of New York, Binghamton*
- Aldo Tambellini**      **BLACK SPIRAL (TV sculpture)**  
**Engineering by Tracy Kinsel & Hank Reinbold** (Awaiting restoration)  
*Collection of the Everson Museum of Art, Syracuse, New York*
- Glen Southworth**      **CVI (COLORADO VIDEO INC) QUANTIZER (Colorizer)**  
**CVI DATA CAMERA (Camera/scan processor)**  
*Collection of the Experimental Television Center, Ltd. & The State University of New York, Binghamton*
- Eric Siegel**      **EVS, ELECTRONIC VIDEO SYNTHESIZER (Analog)**  
*Whereabouts unknown, last in the possession of Al Phillips, documented in photographs*  
**DUAL COLORIZER (Analog)**  
*Collection of the Vasulkas, Santa Fe, New Mexico*
- Stephen Beck**      **DIRECT VIDEO SYNTHESIZER (Analog)**  
*(Awaiting restoration)*  
**BECK VIDEO WEAVER (Digital)**  
*Collection of Stephen Beck, San Francisco*
- Nam June Paik & Shuya Abe**      **PAIK/ABE VIDEO SYNTHESIZER (Keyer & colorizer)**  
**& SCAN MODULATOR (a.k.a. as the "Wobulator")**  
*Collection of the Experimental Television Center, Ltd. & The State University of New York, Binghamton*
- George Brown**      **VIDEO SEQUENCER (a.k.a. FIELD FLIP/FLOP SWITCHER, with digital control)**  
**MULTIKEYER (Analog with digital control)**  
*Collection of the Vasulkas, Santa Fe, New Mexico*
- Dan Sandin**      **IP (Analog IMAGE PROCESSOR)**  
*Collection of Phil Morton, West Yellowstone, Montana*
- Bill Etra & Steve Rutt**      **RUTT/ETRA SCAN PROCESSOR (Analog)**  
*Collection of the Experimental Television Ltd. & The State University of New York, Binghamton*
- David Jones**      **JONES FRAME BUFFER (Digital buffer)**  
*Collection of Gary Hill, Seattle, Washington*
- Don McArthur**      **SAID (SPATIAL AND INTENSITY DIGITIZER)**  
*Collection of the Experimental Television Center, Ltd. & The State University of New York, Binghamton*
- Don McArthur & Jeff Schier**      **DIGITAL IMAGE PROCESSOR**  
*Collection of the Vasulkas, Santa Fe, New Mexico*

# LEE HARRISON III

ANIMAC (Hybrid graphic animation computer), 1962



ON A RECOMMENDATION from Judson Rosebush, Steina and I dropped in on Lee last January. I quickly realized that I knew of Harrison from twenty years ago when Harrison and Rutt/Etra had a patent dispute, a time when everybody's name came up.

I must admit, I was quite taken by Lee's original approach to the stick figure animation. Now I find it simply irresistible. I had to return with David Dunn a month later and we really took him to the cleaners, collecting a number of rare items, from early sixties articles and photos, to a boxful of films.

In my search for the oldest I could find, I stumbled over the film of the ANIMAC, the first and the only machine of its name. "And where is the machine?" we asked eagerly. "On the dump" came the reply!

Once more we realized how hostile the industrial environment could be to a unique machine like this. How many fabulous designs are being destroyed daily just for a few cubic feet of space or the vanity of an engineer promoting his new brood. Of course Lee knew that. "They finally talked me into it!" he said sadly.

Besides the stick figure, well researched, described and conceptualized in a series of patent papers, Lee must have been responsible for a series of sonar analyzing films: very beautiful sets of matrices of vector sticks and expanding/contracting circles, each operating in a different frequency spectrum.

Lee is the true pioneer, clearly predating all the efforts of the legitimate avant-garde. Although his thinking and lifestyle did not belong to the contemporary art scene of the sixties, his work in its concept was visionary and esthetic. Obviously he follows a long tradition of the maveric legendary inventors, working out of their basement or garage. I can see no way in which his project could have succeeded in its totality. I think it was the sudden success of his company which shelved his dream while the rapidly changing technology took away his concept of human figure animation, certainly unique and original. Even as an oddity, it shines in the dawn of the computer age.

—W.V.

**B O R N** 1929 in St. Louis, Missouri. Studied at the School of Fine Arts, Washington University, St. Louis. 1953 U. S. Coast Guard Officer Training, New London, Connecticut: stationed in Long Beach, California, and the Philippines. 1955 Technical illustrator, McDonald Aircraft, St. Louis. 1956-59 Engineering School, Washington University, St. Louis. 1959-65 Engineer at Philco Corporation, Philadelphia. 1965 Bio-cybernetic Engineer at the Denver Research Institute, University of Denver. 1967-68 President, Chairman of the Board, & CEO of Lee Harrison Associates. 1969 Founder & CEO of Computer Imaging Corporation. 1971 President until it closes. Lives in Denver, Colorado.

**" W E S T A R T E D O U T** by developing what later became ANIMAC. At first we called our machine "The Bone Generator" because it made sections of straight lines that could be hooked together and could be individually animated or moved in three dimensional space. To determine what a bone was you had to determine where it was to start in X, Y, Z space, in which direction it went from there, and for how long, in order to determine its length. The parameters that determined which direction it was going in also determined the actual length projected onto the face of the tube. If you saw a bone from the side you saw its full length but if it were pointing toward you, you saw only a portion of it. A bone was composed of a bi-stable multi-vibrator or a flip-flop. To start it was to essentially put a signal on a line



Lee Harrison III (right) receiving the National Academy of Television Arts and Science award for "Outstanding Achievement in Engineering Development," 1972, with his colleague Edwin J. Tajchman (left), V.P. of Engineering at Computer Image Corporation, Denver, Colorado.

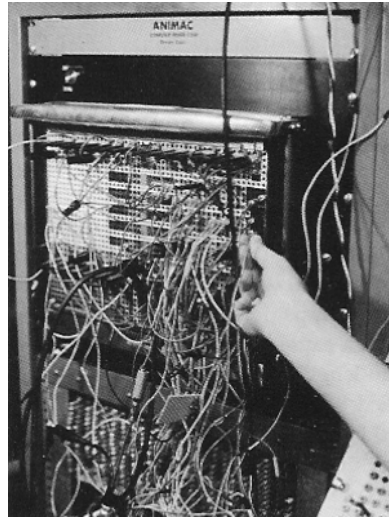

ANIMAC



Lee Harrison III, photo montage featuring a dancer with body mounted sensors controlling real-time animation on the ANIMAC, 1962, Denver.



INFO Frame 306 to 4357



NANO A frame 247 to 10062

that governed the opening of a lot of sampling gates. The inputs to the gates were the parameters that governed the position and some of the qualities and characteristics of that bone. To program it we had a patch panel.

We always had a navel point on our figures and we'd always flip back to the navel point. We'd go up and out an arm and go back to the navel point, go up and out another arm and back to the navel, go up and out to the head. Those were all fly-back bones and we would fly-back by just collapsing the information that was contained on a capacitor.

In order to determine the length of a bone we used time as the basis. We'd start drawing in a certain direction determined by the specific parameters and we'd go in that direction until we'd turned that bone off and then essentially we'd wait there until we drew another bone. The length was determined by plugging a timing circuit into a place which was reset after each bone. When you started a bone you also started that counter and that flip-flop was plugged into the counter that would turn that bone off. It was pretty much all digital. The next bone would be plugged into another count and so forth and you varied the counts depending. A count represented some number of high frequency units that was part of the clock network of the whole machine.

The patch panel was color-coded and it was a big patch panel we got out of the junkyard someplace. If you understood the code you could actually see the bones on this patch panel. There would be a certain color like green and the output might be a blue. If you were going to bone number one, you brought a start pulse that was located somewhere and you'd plug into the first bone and then you'd plug from the output of the first bone into the second bone and so forth. The inputs to the parameter gates were not located on that panel. They were located down a little lower on the face of the Animac and there were hundreds of them. You had all of these hundreds of inputs required to make the thing happen and to change it over time. After this, the main thrust of our development was to make things change over time which eventually culminated in what we called key frame programming where we would turn knobs until we got what we wanted."

—L.H. 3/2/92

## EARLY SCAN PROCESSORS — ANIMAC / SCANIMATE

With ideas predating 1962, Lee Harrison III had the dream of creating animated figures. His idea was to view a stick figure as a collection of lines that could be independently moved and positioned to form an animated character. The figure would be displayed on a Cathode Ray Tube (CRT) and be electronically generated and controlled through vector deflection of an electron beam. Each figure was composed of bones, skin, joints, wrinkles, eyes, and moving lips, all drawn in sequence to create a "cathode ray marionette." The idea evolved into a hardware contraption called ANIMAC which could perform "big animation." ANIMAC was developed in the early 1960's by Lee Harrison and Associates in Pennsylvania.

ANIMAC's basic character starts out as a stick figure, with each stick called a "bone," made from wire-frame line segments. A "skin" is added to the bones by superimposing curlicue springs that modulate the stick vectors with circular sweeps of spinning vectors. The thickness of the bones, or displacement of the rings from the center of the line, is voltage modulated by a "skin scanner." The scanner is constructed from a "flying spot scanner," a vector camera pointing at an intensity graph with higher brightness representing a larger bone displacement. The "joints" or connection of bones to skin are formed by drawing the bones in a specified order, the endpoints being momentarily held till the next bone is drawn. A synthetic mouth, lips and eyeballs are created through parabolas and sine waves modulated with precise control from voltage sources. The entire figure is manipulated in three dimensions by passing the control signals through a three dimensional (3D) rotation matrix. These control signals are formed from horizontal and vertical sweep generators, with camera angle, size and position voltages run through rotation matrices constructed from adders, multipliers and sine/cosine generators.

To give the illusion of depth, an additional camera tracks the intensity of the skin, giving the illusion of an edge by modulating the skin brightness and leaving it in silhouette. This same camera can scan a texture and superimpose it on the skin surface of the bone.

The ANIMAC was largely a proof of concept prototyped with vacuum tubes mounted on 2 by 4's,





# DON BUCHLA

Buchla 100 Series (Audio synthesizer), 1964

WE HAD TWO ENCOUNTERS with Buchla's instruments before we met the man. The first incident took place at Subotnick's NYU music studio on Bleecker street, right above Rogosin's Bleeker Street Cinema. There was a clandestine operation in progress: Subotnick's students were selling their allotted time on the "Buchla" to the public. They even advertised in *The Village Voice*. We picked up Bob Mason's ad and moved some video gear in there one evening. There was a mysterious man living in the room behind the studio. We were introduced later. His name was Serge Tcherepnin.

We started experimenting right away and of course it worked. Those machines were eager to copulate. We modulated the picture by the raw voltages and generated some sounds from the video. Then we got a bit of good luck. A student by the name of Rhys Chatham was eager to experiment free of charge. The next year he was to become the first music director of *The Kitchen*.

There was also a Buchla instrument at the National Center for Experiments in Television in San Francisco. We made a few interesting patches from which two videotapes "Sound Prints" and "Spaces II" survive. Steve Beck arranged for us to meet Buchla at his factory. Don was quite shy and there were a lot of exotic people and exotic smoke in his loft. It was years before we became friends. Now we get a preview of all his new instruments, we even buy them and like them very much indeed. We even adopted his Toyota Landcruiser which he parks in our backyard for his annual trips to the Indian Country. —W.V.

DONALD BUCHLA WAS BORN "somewhere in California." Educated in physics, physiology, and music, his multi-faceted creativity has been applied to fields as diverse as space biophysics research, musical instrument design, and multi-media composition. Much of his work has involved the refinement and utilization of communications channels between man and machine, notably the invention of mobility aids for the visually handicapped, the development of instrumentation for biofeedback and physiological telemetry, and the design of high level music composition languages. His innovative concepts in studio design and the originality and versatility of his musical instruments have led to his international recognition as one of the most progressive inventors on the music circuit.

"I WOULD SAY that philosophically the prime difference in my approach from that of Robert Moog was that I separated sound and structure and he didn't. Control voltages were interchangeable with audio. The advantage of that is that he required only one kind of connector and that modules could serve more than one purpose. There were several drawbacks to that kind of general approach, one of them

being that a module designed to work in the structural domain at the same time as the audio domain has to make compromises. DC offset doesn't make any difference in the sound domain but it makes a big difference in the structural domain, whereas harmonic distortion makes very little difference in the control area but it can be very significant in the audio areas. You also have a matter of just being able to discern what's happening in a system by looking at it. If you have a very complex patch, it's nice to be able to tell what aspect of the patch is the structural part of the music versus what is the signal path and so on. There's a big difference in whether you deal with linear versus exponential functions at the control level and that was a very inhibiting factor in Moog's general approach.

Uncertainty is the basis for a lot of my work. One always operates somewhere between the totally predictable and the totally unpredictable and to me, "source of uncertainty," as we called it, was a way of aiding the composer. The predictabilities could be highly defined or you could have a sequence of totally random numbers. We had voltage control of the randomness and of the rate of change. In this way you could make patterns that were of more interest than patterns that are totally random." —D.B.



Don Buchla

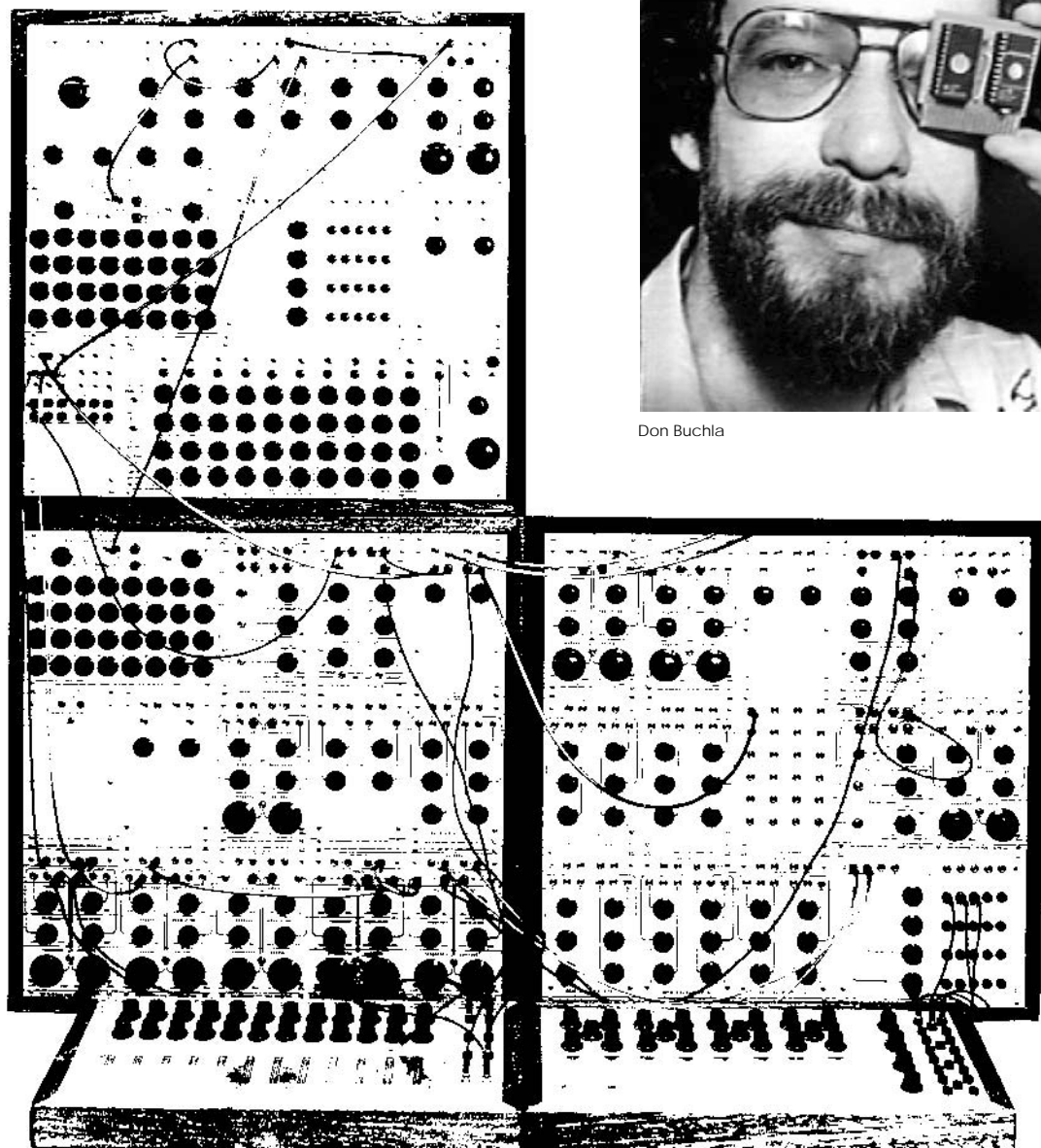

Buchla 100 Series



FRAME 090 step through next 5 frames



STEP BACK



STEP FORWARD

## BUCHLA 100 SERIES

**Model 100 Cabinet**

Specially designed walnut cabinet accommodates power supply and 15 panel units. (Most modules are 4 1/4" x 7" and occupy one panel unit, but some are 8 1/2" or 17" wide and occupy two or four panel units.) Overall dimensions are 23" x 23" x 8".

**Model 106 Mixer**

Two 3-channel mixers with both separate and common outputs and level controls for each input.

**Model 107 Voltage Controlled Mixer**

Two 5-channel mixers with both separate and common outputs. Input levels are controlled by externally applied control voltages usually derived from a Model 114 touch controlled voltage source.

**Model 110 Dual Voltage Controlled Gate**

Two voltage controlled amplifiers generally used in conjunction with a Model 180 attack generator to control the envelope of applied signals.

**Model 111 Dual Ring Modulator**

Two independent ring modulators. Each output consists of the sums and differences between frequency components of two input signals. Original signals are suppressed about 55 db.

**Model 112 Touch Controlled Voltage Source**

Touch activated keys produce one of twelve preselected voltages at each of two outputs. A third output voltage is proportional to finger pressure, and a fourth output is a pulse generated whenever a key is activated. Generally used to initiate notes and control their pitches.

**Model 114 Touch Controlled Voltage Source**

Ten independent, touch activated keys, each with a corresponding control voltage output and pulse output. The voltage outputs are particularly useful for controlling gates (110) or mixers (107), and the pulse outputs for initiating attack waveforms (180) or other events.

**Model 115 Power Supply**

Regulated supply for powering a cabinetful of modules plus one or two keyboards. Installed in Model 100 cabinet, unit occupies no panel space.

**Model 117 Dual Proximity Detector**

Two capacitance-actuated control voltage sources for enabling spatial control of sound parameters. Theremin-style antennas may be remotely located.

**Model 123 Sequential Voltage Source**

Produces a sequence of two to eight programmed voltages at each of three outputs. Switching is accomplished by applying a pulse, usually from a Model 140 pulse generator. Indicator lamps show which of the 24 potentiometers are in control. Eight pulse outputs are energized as corresponding segments are switched. Unit may be used to simultaneously program pitch, amplitude, and duration of single or repetitive sequences of notes.

**Model 124 Patchboard**

Consists of 24 miniature audio jacks mounted on a panel. Used in studio installations to facilitate connection to tape recorders, monitors, and other auxiliary equipment.

**Model 130 Dual Envelope Detector**

Produces a control voltage proportional to the instantaneous amplitude of an applied signal. Detector time constant is variable from .01 to 1 second.

**Model 144 Dual Square Wave Oscillator**

Two independent oscillators in one unit. Frequencies are continuously variable from 5 cps to 20 kc and may be controlled internally or with externally applied voltages. There is provision for wide band amplitude and frequency modulation.

**Model 146 Sequential Voltage Source**

Produces a sequence of two to sixteen programmed voltages at each of three outputs. Otherwise identical to Model 123.

**Model 148 Harmonic Generator**

Generates a fundamental and its first nine harmonics (harmonic numbers 1 - 10). Fundamental frequency is continuously variable from 5 cps to 5 kc and may be controlled internally or with an externally applied voltage. There is provision for wide-band frequency modulation. The 148 is frequently used in conjunction with mixers (106, 107), gates (110), and attack generators (180) to enable precise programmed envelope control of individual overtones.

**Model 150 Frequency Counter**

Four digit counter measures frequencies to 100 kc with a precision of 10 cps. Frequencies below 10 kc are measured with a precision of 1 cps.

**Model 155 Dual Integrator**

Produces continuous control voltage functions when used in conjunction with sources of discrete control voltages (e.g. keyboards, sequencers). Positive and

negative slopes may be individually and continuously varied from 15 volts in .0025 seconds to 15 volts in 10 seconds; either or both slopes may be voltage controlled. Particularly useful for generating complex voltage controlled envelopes, frequency glides, and repetitive control functions.

**Model 156 Dual Control Voltage Processor**

Serves to mix, compress and invert control voltages. Each channel has two control voltage inputs and an internal voltage source. Particularly useful for obtaining fine pitch control, transposition capability, and range compression of control voltage sources.

**Model 157 Control Voltage Inverter**

Four channel unit complements control voltages to accomplish a variety of inverted functions.

**Model 158 Dual Sine-Sawtooth Oscillator**

Two independent oscillators in one unit. Frequencies are continuously variable from 5 cps to 20 kc and may be controlled internally or with externally applied control voltages. Waveshape is continuously adjustable from sine to sawtooth; oscillators may be wideband frequency modulated.

**Model 160 White Noise Generator**

Produces white noise with a flat frequency distribution from 5 cps to 20 kc and weighted noise with a constant power per octave distribution.

**Model 165 Dual Random Voltage Source**

Produces two uncorrelated, random output voltages, each of which is changed by applying a trigger pulse. Used to randomize frequency, amplitude, and time.

**Model 170 Dual Microphone Preamplifier**

Two high-gain mike preamplifiers. Input connectors are 3 pin XLR. Input impedances are selected by a panel mounted switch.

**Model 171 Dual Instrument Preamplifier**

Two preamplifiers for electric guitars, contact microphones, and other low-level signal sources. Input impedances are 200 k (omega symbol); input connectors are standard phone.

**Model 172 Dual Signal Leveler**

Two high-gain, constant-output amplifiers. Output signal levels are maintained at 0 db (plus or minus 1 db) for input variations of from -40 db to +10 db. Time constants are variable from .05 to 5 seconds.

**Model 175 Dual Equalizer - Line Driver**

Used in studio installations to drive 600 (omega symbol) headsets or unbalanced lines at a nominal +4 db (max. +20 db). Unit incorporates bass and treble controls of the variable turnover variety.

**Model 176 Dual Hiss Cutter**

Reduces tape hiss by restricting bandwidth of signals that would otherwise be masked by high frequency noise. Signals above a certain threshold (including fast transients) are unaffected.

**Model 180 Dual Attack Generator**

Two independent units produce envelope control voltages initiated by pulses. Attack time is variable from .002 to 1 second; decay time from .002 to 5 seconds; duration from .002 to 5 seconds. Duration may be optionally controlled by trigger pulse length.

**Model 185 Frequency Shifter**

Shifts frequencies contained in input signal by an amount equal to the applied carrier frequency. Raised and lowered signals are simultaneously available.

**Model 190 Dual Reverberation Unit**

Two independent spring type reverberators. Degree of reverberation is continuously variable.

**Model 191 Sharp Cutoff Filter**

Voltage controlled highpass and lowpass filters with 24 db/octave slopes. Cutoff frequencies are variable from 5 cps to 20 kc with no range shifting. Also functions as a bandpass filter with voltage controlled center frequency and bandwidth.

**Model 192 Dual Lowpass Filter**

Two lowpass filters with cutoff frequencies variable from 200 cps to 20 kc. Slopes have sharp knees and are 12 db/octave.

**Model 194 Bandpass Filter**

Divides an input signal into four frequency bands. Cross-over frequencies are 200 cps, 900 cps, and 4 kc. Slopes have sharp knees and are 12 db/octave.

**Model 195 Octave Format Filter**

Divides an input signal into ten frequency bands centered at octave intervals from 31 cps to 16 kc.

**Model 196 Phase Shifter**

Shifts phase of input signal such that a 90 degree (plus or minus 5 degree) phase relationship between the two outputs is maintained from 5 cps to 20 kc. Used in conjunction with ring modulators for frequency shifting or for exotic visual displays.



# ROBERT MOOG

## Moog Modular Audio Synthesizer, 1964

THE OMNIPRESENT Richard Lowenberg brought us right to the beast. "The Moog" was a series of black closets with intimidating front panels, crisscrossed with tens of patchcords.

It must have been somewhere on Fifth or Park, a Mid-town place that was elegant and pleasant. The music-man operating the Moog fit the interior (although we somehow had the impression that neither the interior nor the instrument belonged to him). Gino Pisserchio was his name and we later learned he was an early Andy Warhol star.

We brought a tape, a movement/dance improvisation, and patched the video into the Moog. The resultant success was the work of the patch: peaks of video triggering the sequencer steps. Later we went through another adventure in interactivity with Lowenberg. We hired a dancer by the name of Kei Takei and wired her up for muscle monitoring. —W.V.

ROBERT Arthur Moog was born in Flushing New York in 1934. He took degrees in physics from Queens College, New York, in electrical engineering from Columbia University, and received a Ph.D. in engineering physics from Cornell University in 1965. In the mid-50s he founded the R. A. Moog Co. for the manufacture of theremins; the company began making electronic music synthesizers in 1965 which became its primary concern. Moog's first synthesizers were designed in collaboration with the composers Herbert A. Deutsch, and Walter Carlos; other composers who have since worked with Moog include John Cage, David Tudor, Gordon Mumma, Richard Teitelbaum, Chris Swanson, and David Borden. With the success of Walter Carlos' Switched On Bach recording released in 1969 which uses a Moog synthesizer, Moog's name and equipment have become widely identified with electronic synthesizers. Moog is currently active in music research and in the development of new instruments, with particular interest in evolving more sophisticated control devices and more complex ways of applying control signals to add aural interest to sounds.

ROBERT MOOG IS WELL ALONG *the way to joining those men whose last names have become common nouns in the language. Although the Moog Synthesizer is only one of several manufactured synthesizers, increasingly these days, a "Moog" means a music synthesizer.*

*Moog lives and works in Trumansburg, NY. You can get there by taking route 96 north out of Ithaca, up the west side of Cayuga Lake. The R.A. Moog Corporation is located in a white, two-story main street building, next to the local drug store, and across the street from a service station, on the right as you come into town from the south.*

*Inside and up a long flight of stairs you meet a receptionist, who will wind you through two drafting rooms and into a large room scattered with drawings, tape recorders, synthesizer components and drafting tables. Moog's desk is the far one on the right, next to the window, with the computer print-out of Snoopy hanging above.*

*Bob Moog does not look like you'd expect him to. That is to say he is not a weirdo long-hair electronic freak who looks like he has just grabbed a capacitor. His build is slender, and he might be described as looking "straight." He is reserved, but cordial.*

*Before sitting down to talk, we toured the plant, looking at the assembly room and cabinet shop downstairs. Since the permanently installed synthesizer downstairs was being used, we returned to his "office" for a demonstration on a smaller portable model. After looking at a tape deck built by Magnetic Recording, for which Moog's company is designing*



FRAME 069 step through next 5 frames



STEP FORWARD



STEP BACK



Robert A. Moog at conference on Electronic Art Tools, at SUNY, Buffalo, 1977



MOOG Modular Audio Synthesizer, 1968-69

*electronics, we sat down again, rolled our tape recorder, and began.*

*J.R.: How did you get into this?*

MOOG: Out of interest. I began working with an electronic music composer and we developed some of the first ideas and then it just grew from there.

*About when was this?*

Well, we began in '63.

*Had you been tied in with any of RCA's synthesizer work in the middle '50s?*

No, I was independent. Remember that Victor never made anything commercially. It was just an experiment.

*Do you perform yourself?*

No! We sponsored a concert in New York, but I am not a performing musician. I'm purely a designer.

*Is each unit custom built today?*

A lot of them are standard synthesizer systems now. Most of our synthesizers are built out of standard modules, but we do some custom work. The module is the component of the synthesizer.

*Is it all built here?*

Yeah. The cabinets are built here and the modules are all assembled here.

*The unusual quality about this whole thing, I guess, is the fact that it's been so long since a new major musical instrument has come out.*

Well, it's too early to tell if this is going to be accepted in the long run. For instance, in 1929 and 1930 there was a huge flurry of excitement about the theremin. Today a lot of people don't even know what a theremin is. No one plays it.

*Do you think a lot of people, like rock bands, are buying these because it is like a sophisticated organ, just another keyboard accessory, and aren't utilizing it?*

It's true. It's years before you really know basically what a synthesizer is musically.

*It seems like many of the people in the pop field haven't really gotten into it.*

It will be years. Dick Hyman is learning, but he is learning slowly. The trouble is that guys like him and Peter Nero and George Harrison are successful pop musicians who have made a shithouse full of money, you know, with traditional instruments and they are not psychologically prepared to bust their hump to really do a job in a new medium because they are making so much money in the old one. So they skim a little cream off the top. Publicity value, and that's it. But Hyman is doing things, he's working.



INFO Frame 16508 to 18820

*You just don't hear that much good stuff.*

No, there isn't that much around. That's the shortage.

*Does it take a special type of mentality to work with a Moog?*

I suppose it does, but we can't characterize it. It takes a guy who's a good musician, and likes to work alone, and has a rational mind.

*Why don't you try to explain to me how a Moog synthesizer differs from an electronic organ in the way it develops or duplicates sound.*

An organ is a device on which you can play as many notes as you want. There are a great many note generators or oscillators in it. And that's about all there are. If you play one note the note, has a simple tone color, a tone color that cannot be varied or shaped by the musician as it is being played. You put your finger on a key, the note starts, you lift your finger from the key, the note stops. That sort of tone, a tone that does not vary as it goes on, is only one of a great many types of musical tones.

Just about all other musical tones vary a great deal as they go on. When a violinist plays he is constantly moving his hands, changing the amount of pressure with the bow. And these things result in variations in pitch, tone color and loudness. These greatly affect the expressive content of the sounding of the music that is made up from sounds.

What the synthesizer is all about is giving this sort of control over the sounds to the musician. Once the musician sets up a sound he can then impart as many variations as he wants into the various properties of the sounds, either directly with his hands, or by mechanical means, program means.

That's the difference between a synthesizer and an organ. The same difference exists between a trumpet and an organ. The synthesizer plays one note at a time, and at the most two or three, but those can be shaped very carefully.

We would also allow for its speed to build up with a characteristic time. All these things I mention correspond to a simple electronic mode of operation that you establish with one or two patch cords, and one or two dial settings. What the musician gets used to is thinking in terms of these operations, which have direct musical meaning . . .

*Actually, since you are controlling with, for example,*

*a keyboard, could you use your keyboard to not only change your oscillator, but control other functions too?*

Yes. We can use the keyboard to change anything that is changeable at all.

*But it isn't necessary to have a keyboard to control the instrument?*

Right. There is usually a keyboard, but the keyboard is only one way of controlling the instrument, of playing it.

*If you want to make a "replica" of a sound . . . like reproduce a trumpet or violin, how do you . . . ?*

Musicians don't usually think of making replicas. It is sort of a futile exercise. The synthesizer works according to a certain pattern of logic and by using this pattern of logic you can construct a great many sounds, some of which are trumpet-like, some of which are violin-like, and some of which you never heard before. But if you think in terms of starting with something that makes sense with acoustical instruments and trying to force the synthesizer to do that, you'll generally fail. You think more in terms of following the logic of the synthesizer, of the sort of things it can do well, to get the sort of tone color as close to the sort of tone color you want.

*Could you elaborate on that? Where does it excel?*

Let's assume we want to build a violin-like sound, as an example. We are never going to make a sound that is completely violin-like, because a synthesizer doesn't function like a violin.

We can do the following things: First we can pick a wave-form that's close to the wave-form of a vibrating string that's being bowed. Right? Then we can pick a filter that has the same resonant characteristics as the body of a violin. Okay, so far so good. Now, we can shape the loudness, causing it to build up in the same way as a violinist does when he puts the bow down on the string. The loudness builds with a certain characteristic time. So when a violinist plays, when he starts a note, he'll put the bow down on the string and he'll gradually, with his left hand on the finger board, build up a vibrato, both in speed and intensity. He'll start off very slowly, and then build up faster. This is for a long violin tone.

Suppose you want to do the same thing on a synthesizer. Well, what we could do is use another periodic generator, or oscillator, to produce a slow variation that would correspond to the vibrato, a



variation of six cycles per second. We would arrange for that to build up with a certain characteristic time, just the same way as we allowed for the sound itself to build up with a characteristic time.

*How else would you do it?*

A computer program. Other control devices, manual control devices like a ribbon controller. Sequential control which allows you to set up automatic patterns. The simplest way is, of course, just turning the dials on the instruments themselves. And there is what we might call analogue programming . . . using other modular instruments to produce the contours of the variations.

*What type of work is being done with computer programming into the control circuits?*

The most interesting work is being done at Bell Labs. They set up a fairly elaborate program to enable assembly of sound sequences and edit them. The most interesting part is the array of input points. They have a couple of keyboards and a joy stick-like affair and pots, a panel full of pots. They have a great big cathode ray tube.

The output of this program, the output of the computer I should say, contains 14 signals, control signals, and they go off to the oscillators and amplifiers and so on and produce the variations. Well, these 14 signals are plotted on the cathode ray tube at the same time, and so you have 14 little squiggly lines. And a vertical line goes across the screen and tells you where you are in time, as time progresses.

Then you can stop it, you can stop the parameters and you can vary any of the 14 parameters, move it up or down and then go right on. I think it is a light pen that they use. You know, without touching tape, without even getting involved with tape you can edit the whole thing. Really beautiful.

*Is any of this available on record?*

There's no music on it, it's just experimental work.

*Are you involved much with the creating of special new sounds, like the human voice?*

Not really. Carlos did a little of that in Well-Tempered Synthesizer, but we're not really into that. It is something the computer people are very interested in, as a method of giving the computer a voice.

*Where is your primary design effort going?*

Two or three areas. It's in improving the circuitry of

what we have now. And in opening up two new markets. One of them is a small, light portable unit that rock groups might use . . . keyboard accessories. And the other is teaching equipment for high schools that are interested in electronic music.

*Is your biggest market now with the classical people or the rock bands?*

What does classical mean?

*Well, serious music.*

Half go to serious composers and universities, and half go to recording people . . . recording studios and independent commercial producers.

*Somehow I'd gotten the idea that some of the serious music composers consider the Moog a late comer that is not totally welcome. Like progress stopped with the synthesizer built by RCA.*

That's one extreme point of view, I'd say. The fact is the RCA sound synthesizer has been used by eight or 10 people in the world, ever, in any music hall. It costs nearly \$200,000. Our customers number in the hundreds, and I think as far as they are concerned, our equipment is welcome.

*What is the Buchla?*

Well, it is a synthesizer developed independently from ours. It uses some of the same ideas, and some are different. The differences are in the way it is organized. The Buchla is organized toward making automatic sequences of sound. Any sound is rather simple. Ours is not organized to make automatic sequences like the Buchla; it's organized to playing the sounds, but where the sounds can be very complex.

*What's the effect of the new quadrasonic stereo?*

Well, some electronic music composers have been doing that for years. Now the Columbia-Princeton people never did anything else except four channel sound. How important it will be commercially I can't say.

*Where do you get your ideas from?*

It's a combination. Many come from musicians and some come from our engineering people here. It is very much of an interrelated thing.

— Judson Rosebush, 1972

# BILL HEARN

VIDIUM (Analog XYZ driver/sequencer), 1969

ONE FOGGY SUMMER day in San Francisco, near Golden Gate Park, we saw a most peculiar building. We walked in without anybody noticing until we came to a halt in front of the most beautiful electronic picture-making instrument we had ever seen. "You are in the Exploratorium and I am Bill Hearn", said the man leaning over the instrument.

We were to later meet Bill many times and he was to become one of the most prolific instrument builders in video. He was in full concentration over the "Vidium". I have no other recollection of our conversation and apparently neither does he..

From Skip Sweeney we learned that he also built a colorizer which they had at Video Free America. We were invited to come over and play. We were very impressed by the way VFA had built an alternate institution and quickly pronounced Skip the Unequivocal Master Of Video Feedback, a title not contested to this date..

Hearn's career continues to this day. Many video artists have made masterpieces on Hearn's Lab, notably Ernie Gusella and in this world of quick obsolescence, Steina is still using two of his old instruments.

—W.V.

CURRENTLY William Hearn is a Staff Scientist Engineer in the Electronics Engineering Department at the Lawrence Berkeley Laboratory, University of California. Educated in engineering at Berkeley, he has been employed since 1973 in the Accelerator and Fusion Research Division at LBL, where he was instrumental in the development of the EBIT (Electron Beam Ion Trap), the Tandem, the Magnetic Fusion Experiment, Real Time Systems , and the Heavy Ion Linear Accelerator. He has several patents issued in his name.



INFO Frame 14926 to 18820

"I WAS A CURATOR at the Exploratorium and I had designed a really large console that made complex color lissajous patterns: multiple locked oscillators and pseudo-three dimensional shapes. I always thought they were quite beautiful. They had been used in a couple of different applications but I made a large console that would generate great families of them.

I got the idea from somebody else in New York who had done it long before me. I saw what he had done. I improved the deflection amplifiers to give a really good response and I developed a system of color modulation which I have a patent on. I painted color on the surface according to the convolution of the surface.

The monochromatic versions were beautiful, very lacy and sharp. They had a very sharp trace on the electromagnetic CRT. And if you can deflect the beam, which is very difficult, you can get beautiful patterns from voice or recorded music.

For color the basic trick is that the color is a function of the velocity of the trace as it moves on the screen. As the trace moves, the color stretches toward the red end of the spectrum. You know what the spectrum looks like. It starts at red and goes through orange, yellow, green, blue and then violet. I assigned colors according to the actual velocity of



Bill Hearn in the mid-60s

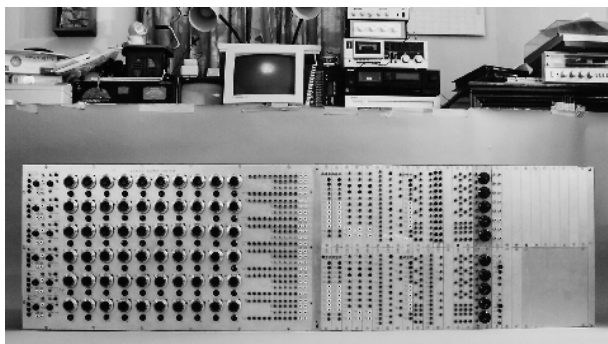

VIDIUM

the trace on the screen. I had circuits which could measure the velocity and change the color of the dot as it was moving. In doing that it made the contours of the image stand out in a really interesting way.

It's been many years since I've done a thing on it because it was such a dead end. I found that it was quite interesting and beautiful but it had no commercial application. People in special effects, film or advertising all have very tried and true techniques that they stick to. They don't want anybody coming in and disturbing their nice game.

I paid for all of it myself up to the point where I got some exposure, and a very wonderful man named Al Leavitt here in San Francisco, who later turned out to be a kind of pain in the ass, saw it. He loved it and he said we should exploit this. I said fine and he made a contract with me through negotiations with my attorney. We formed the Color Communications Corporation. Al put in \$30,000 and I put in my patent and then he died. I never would have been able to do what I did if Al had lived. That's the funny part of it. He died of a heart attack at the beginning of the project and the money was in the bank and I went ahead and built this thing.

Through EAT I met a number of budding electronic music composers. I helped them build music synthesizers and when I developed the Vidium, they

found that it was a really sympathetic way of producing images directly from their signals to get a visual synthesis of what they were doing sonically. Don Buchla came by for a few meetings and I think David Tudor was very interested in it.

Don Buchla was the strongest influence I ever had in terms of the way he did things. If you look at this you'll see that it's very similar to his synthesizers in the philosophy of what it does: control voltages, logic voltages, signal voltages and unshielded banana jacks, so that you can stack them which makes the flow much simpler. I think technically you can say that this machine could have been designed by Don Buchla.

The people at Video Free America in Berkeley asked me to make a colorizer for them: Arthur Ginsberg, Skip Sweeney and Alan Shulman. They showed me that they had a colorizer but when they opened it up all the parts fell out. It was a little thing in a gray box about this big and it cost \$800. It had two knobs on it and made a smeary color. I said, "we can do better than that." At that point I evolved the concept of the zone colorizer to cut the gray scale into segments.

What I really lust after is to make machines that are so clear to a creative person and gives them so many possibilities that they can use them. It just gives me a terrific thrill when I see someone like Ernie Gusella in New York who's doing truly creative work with the Videolab." —B.H.

**THE VIDIU** “MK II” is a hybrid analog synthesizer which acts as a “hyper Lissajous pattern generator.” Developed by Bill Hearn in the early 1970’s, the Vidium was inspired by earlier color XY display art and an exhibit called “Sidebands” at the Exploratorium in San Francisco. The fascination with animated color shapes driven from sound formed the basis for Vidium. Numerous XY displays and audio function generators were tried before arriving at the current form of the MK II unit.

The basic Lissajous pattern is generated through two waveforms attached to an X/Y display screen (or oscilloscope set in XY mode) with two sine waves driving the horizontal and vertical deflection circuits. With the X axis sinewave “in-phase” and the Y axis “out-of-phase” a shape is seen on the display. If the phase shift is 90 degrees, a circle is formed, with 45 degrees an ellipse is seen, and with 0 degrees of shift a diagonal line is seen.

The Vidium drives each axis with independent oscillators while inserting precise phase shifts and modulation signals to create elaborate shapes. These are expansions on the classic circle and figure eight pattern appearing as “harmonically pinched doughnuts” and vector textures of slowly changing form. Programmable waveforms of sinewaves shift into triangle waves, and then into square waves to deflect the XY display beam, forming sinuous curves and boundaries.

A modified color television is used for the X,Y display with the deflection yoke replaced with a new yoke driven from audio amplifiers. The audio amp is in turn driven from the main analog waveform generator rack. Color is added by wiring to the color “hue control”, forming a voltage controlled phase shifter, and wrapping, in phase, 540 degrees of the normal 360 degree hue space. Color saturation and brightness is set by the TV’s front panel controls. A special analog velocity/position detector calculates: the square root ( $X^2 + Y^2$ ) of the deflection signals that feed the color hue shifter. A threshold detector blanks the beam if the X and Y settles to zero. This suppresses the beam of a stationary dot at the center of the display, which can “burn out” the screen phosphor. The hue shifter allows drawing of textural surfaces in smoothly changing colors. The hue shift tracks the shapes automatically.

The main control box consists of two, 3 foot by 3 foot, racks mounted side by side. The left side

contains the “voltage sequencer” outputs with 60 multi-turn knobs called Helipot, while the right side of the control rack contains the control and signal processing modules.

The main control of the synthesizer is an Analog Voltage Sequencer. The “sequenced voltage source” has six controllable “steps”, each “gating ON” 10 voltages; the voltages set by ten-turn potentiometers located on the left half of the rack. This six by ten matrix of voltages is interconnected through “Pomona Stacking Banana Plug cords” to other modules located on the right half of the rack. Commonly the sequencer is wired in a tandem chain of modules: the first module triggers the second module etc., until the sixth sequencer step is triggered. An oscillator or button at the front end starts up the chain of events. Each “step” has a time delay (a monostable multivibrator), and a light bulb to indicate that it has been triggered. Output jacks for OSC START, SEQ OUT and EOS (end of sequence) are used to connect to the next module in the sequencer chain.

Control voltages are available on colored banana jacks with RED representing analog outputs, BLUE for analog inputs, BLACK for digital inputs and WHITE for digital outputs. The digital output signals have a “Wired-Or” property to tie multiple outputs together with the lower voltage being the victor. The Analog Voltage Sequencer can have its outputs tied together due to its “bare-collector” output stage. This allows the sequencer to “switch-on” up to ten voltages for each step in a sequence.

The pattern generator side is built around basic sinewaves and phase shifted sinewaves. The modules consist of oscillator frequency sources and processing modules. Multiple oscillators are present, including a voltage controlled function generator. This allows for voltage control of its frequency and phase, and an external sync input. The output generates a collection of waveforms: triangle, square, sawtooth and sine. A digital version of the “trigger out” and a waveform triggered indicator, “logic out”, are made available on separate jacks. A more elaborate version was proposed to allow voltage control of waveform shape; the input voltage would shift the output waveform from sine through triangle to square.

Another signal source is an envelope generator. A trigger pulse, “ENV START”, starts a pulse output, and “ENV STOP” turns off the pulse. The rise/fall

time of this pulse is voltage controlled and digital outputs indicate that the envelope has triggered. The envelope pulse is combined with the main oscillators to smoothly shape the underlying waveform.

Closely tied to the idea of Lissajous pattern generation is the need for controlled phase shift of the sine wave signal. To accommodate this, a modified "All-Pass" filter circuit is available where the input signal is phase-shifted in response to an external voltage control.

For processing of waveforms, a Voltage Controlled DC coupled Amplifier is present, acting as a two quadrant multiplier with a summing input stage. The amplifier sums together multiple inputs while the voltage control input attenuates the summed result and sends it to output. The control signal can come from the envelope generator, the sequencer voltage or the oscillator waveform: Output =  $(In_1 + In_2) \times Control$ .

A precision Four quadrant multiplier with two sets of inputs, A and B with inverting and non-inverting polarities is used to modulate the oscillator waveforms: Output =  $(In_{A1} - In_{A2}) \times (In_{B1} - In_{B2})$ . These four quadrants allow both attenuation and inversion of input waveforms.

The combination of the Voltage controlled summing AMPs, with Four Quadrant multipliers and

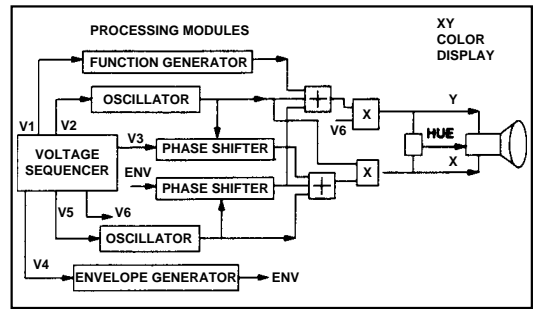

phase shifters, allow the multiple oscillators, envelopes and knob control voltages to mingle their signals into curious patterns of X and Y signals. The hue shifts are closely linked to the pattern drawn by the X and Y waveforms, forming the unique interlocked VIDUIM Lissajous surfaces.

The front panel was constructed by Joshua Partridge and the circuit boards were assembled and tested by Richard Rhoda. Bill Hearn designed the detailed circuits and originated the concept for VIDUIM. He holds a U.S. patent based upon the color display subsystem titled "Visual Display of Complex Color Television Soundwave Signals", number 3,627,912, granted on December 14, 1971.

—J.S.

# EMS

## Putney, Model VCS 3 (Audio Synthesizer) 1968

BEFORE THERE WERE ANY video synthesizers, there were many kinds of oscillators. J.P. Boyer talked about the process of heterodyne where two known frequencies create the famous interference pattern as the basic synthetic principle. That's what the audio synthesizers had in their guts: a bunch of oscillators.

Mr. Mayer and his son seemed to peddle them from loft to loft in NYC, all five story walk-ups. I recall sending him from my five stories up to Ernie Gusella, five stories up at Forsyth Street.

Clearly, in comparison to audio, the video synthesizers have failed to proliferate. In most cases, they were only one of a kind. They came still born, or half blind with learning disabilities. They meant more by their concept and ideology than by their visual product. But as Paik predicted, they had to come nevertheless.

The Putney was a mortal blow to my ambitions in film. This was the first time where the big God's studio of the "Outside" just fit into a small wooden box from England. —W.V.

### SPECIFICATIONS

#### PUTNEY (MODEL VCS 3)

Power Supply: 220-240, or 105-115VAC, 50 or 60 cps. (battery operation is also possible—details on request).

Input Sensitivities: High Gain Inputs: 2 X 5mV AC into 600 ohms.

Low Gain Inputs: 2 X -2.5—0 plus or minus 2.5VDC into 47 K-ohms.

(Although the studio is self-generating and no input is required to produce a very large range of sounds, high gain AC inputs are provided so that microphones and other audio signals can be fed into the studio, and high impedance DC inputs so that external control voltages may be applied).

Output: 2 X 10V into 50 ohms (without panning facility—normally for driving amplifiers, tape recorders, etc.).

Line Level Outputs: 2 X 2V into 600 ohms (with panning facility—normally a headphones output).

DC Output: A control voltage can be brought out and applied to another device.

Every sound device has level controls for each output. There are three voltage controlled oscillators with various waveforms. Two of them are primarily designed for audio signals, while the third has a frequency range extending far below the audio

spectrum, and is intended principally for control. But all three can be used for either purpose, and oscillatory waveforms are available elsewhere as well. A combination of highly stable design and a stabilized power supply ensures a virtually drift-free performance from all three oscillators.

Oscillator 1. This has sine and ramp waveforms, and covers the large range of 1Hz to 20 KHz in one range, without switching. The two separate outputs can be mixed if so desired to provide a large range of timbres. Frequency control (as well as that of Oscillators 2 and 3) is by slow motion dial.

Oscillator 2. This generator has the same frequency range as Oscillator 1, and also has two outputs, but in this case the alternatives are square and ramp, and a shape control enables the waveform to be varied from asymmetrical (short pulse and sawtooth) through a symmetrical (square and triangle) to a mirror image asymmetrical with polarities opposite to those of the first position.

Oscillator 3. This has exactly the same waveform control arrangements as Oscillator 2, but has a specially low frequency range, extending from approximately 1 cycle every 20 seconds (.05 Hz) to 500 Hz. Thus very slow transitions of voltage control can be made.



INFO Frame 21367 to 24259

## TREATMENTS

**Envelope Generator (Attack/Decay).** This device has four time controls—attack-time, on-time, decay-time (which can also be voltage controlled), and off-time. The off-time control can be set so that repetition is automatic at a wide range of speeds, or so that a button or external switch must be pressed to activate each cycle. As mentioned above (Source No. 6) the repetition frequency of this generator is also available as a control trapezoid waveform.

**Reverberation.** A spring reverberation unit has a reverberation/direct signal ratio which can be either manually or voltage controlled, as well as an output level control.

**Trapezoid Output from Envelope Generator.** This output is available whether or not the attack/delay facility is being used. Normally a low frequency, it provides another shape of control waveform.

**Noise Generator.** This has amplitude and coloration controls, so that various bandwidths of noise can be obtained at any level.

**Ring Modulator.** This very advanced I.C. modulator has a high carrier rejection and low distortion. The only control needed is output level.

**External Sources.** Up to two simultaneous external sources (for example, a microphone and an external oscillator, or a second VCS 3 and a prepared tape) can be fed into the studio, where they can be processed with internally generated sources.

**Filtering.** A bandpass filter with manually controlled "Q" and manually or voltage controlled center frequency. When the "Q" is sharpened beyond a certain point the circuit becomes an oscillator (Source No. 5).

**Filter Used as Oscillator.** When the filter (see below) is adjusted so that it is self-oscillatory, it produces a very pure sine and wave output. Both filter and oscillator functions cannot, however, be used at the same time.

## MONITORING AND PATCHING

A meter is provided which can be plugged to read any required parameter. It can be used to log AC levels accurately, or as a center-zero DC meter to monitor subsonic waveforms which cannot be checked by ear. (If other indicating devices, such as an oscilloscope or a frequency meter, are available,



Putney, Model VCS 3 (Audio Synthesizer)

it is a simple matter to connect them to the VCS 3). The patching is by a 16 x 16 way pin-panel matrix, completely eliminating unreliable and untidy cord patching. As well as being clearly labelled in words, the matrix carries a letter and number code which is repeated on the panel near the appropriate control. Each of the 256 locations in the matrix board can therefore be designated by simple map reference (B12, G4 for example). In addition, perforated templates can be marked with selected locations and placed in position over the matrix board, making pin plugging literally child's play.

## MANUAL CONTROL

As well as the attack/decay button mentioned above (Treatment No. 1), the studio is provided with a joystick which enables any two control parameters to be varied simultaneously with one hand, and the joystick is so placed that it and the button can both be operated by the right hand, leaving the other free for altering knobs or matrix plugging. In addition EMS will shortly announce a range of peripheral equipment, including a keyboard which it will be possible to add to an existing VCS 3 by simply plugging it in, a special DIN socket having been provided for this purpose.

## INPUT AND OUTPUT AMPLIFIERS

The input amplifiers (see general specification above) each have a level control on the panel. The two output amplifiers not only have tone controls as well as level controls, but can also be voltage controlled, so that amplitude modulation and automatic fades and crossfades can be applied. Pan controls, which cross one channel to the other, are available on the line outputs.

# ALDO TAMBELLINI

**Black Spiral (TV Sculpture), 1969**



I PERSONALLY regard Tambellini's and Paik's concerns in the sixties as the true and direct inspiration to our generation of "synthesizing" artists. We had spotted Aldo's theater on Second Avenue, the Black Gate, and later when I met him, he indeed dressed in black. He was obviously a walking manifesto, obsessed and fully committed. He made a fabulous film with black kids and was dedicated to the black cause.

His artform seemed to center on a field of the blackest black, with a figure of light as the protagonist. I never read nor talked to him about it, nor do I understand why he had chosen electronic images as a part of his arsenal.

Of course, the Black Spiral made a completely different statement. Clearly it spoke to the perceptual issue so close to my own concerns. We would discuss the presentation of a frame in painting, photography, film and of course in video. The regularity of drawing a frame of video from left to right, from top to bottom was always suspect as the most unimaginative, traditional "reading of the book". Aldo's concept challenged that. But in spite of its elegance, as in all mythology of perception, the case remains inconclusive.

We exerted quite a disproportional effort to get his instrument exhibited. It is now at the Everson Museum in their depository. We even got Dave Jones to drive there and estimate the restoration cost. We also located one of the original builders at Bell Labs, but somehow the instrument could not be materialized on time. It shall have to wait for the next show. —W.V.

**ALDO TAMBELLINI WAS BORN** in 1930 in Syracuse, N.Y. He received a B.F.A. in Painting from the University of Syracuse and a M.F.A. in Sculpture from Notre Dame University. He was the founder of the "Black Gate" Electromedia Theater of environmental performances encompassing all areas of light, sound and motion. He has been particularly involved in film, television programming, communications and their impact on education. In 1969 he won the International Grand Prix, Oberhausen Film Festival.

**IN COLLABORATION WITH** Tracy Kinsler and Hank Reinbold of Bell Labs. Nature, as we will see it in the future, in circular or spiral form. No up — No down — No gravity. Floating. From live broadcasts.

"And what are we going to do through the media? Let's say we are going to keep it open and whatever I think is possible I would like to do. Whatever one might dream of which somebody would not want

if I had the possibility to do it. Let's break all the rules possible. Let's open up the possibility which everyone else has told you this is not right and this is not feasible. And I would like to start it from there, from a reality. So what one wants to do is more like an attitude rather than the specific of what one wants to do."

"To show that light is a constant moving force, an ever changing form. That light is energy and energy is going through us, the same energy which is going through the universe today. And when creative people begin to get involved, with this idea of energy rather than the idea of making pictures, then we will come to some creative aspect not belonging to one particular class but toward a new exploration which is for all . . ." —A.T.



Frame 100 step through next 5 frames



STEP FORWARD



STEP BACK





Aldo Tambellini with Black Spiral prepared television set, 1969. Photo: Don Snyder



INFO Frame 24260 to 25137

# GLEN SOUTHWORTH

CVI Quantizer (Colorizer), 1969

CVI Data Camera (Camera/scan processor), 1970

WHEN I TALKED TO RALPH Hocking last fall about this show, the name of Colorado Video popped up. "I am collecting Colorado Video stuff", said Ralph. That was it!. Something I never consciously realized was there all the time. Now I am "collecting" Colorado Video from Los Alamos, the largest electronic and atomic junk pile known as the Black Hole, run by an eccentric Ed Grotus.

I have always loved junkyards. Europe after the war was a huge junkyard. I remember the thrill of the ultimate autopsy when the lid of the mysterious black box finally came off.

Glen Southworth, the founder of Colorado Video, would not like this talk. He ran the finest picture-making instrument-factory on this planet at one time. We could never afford one, they were of that class, but we always kept a fresh catalog on hand.

He was with us most of the time, or slightly ahead, in a different, slightly warped industrial dimension. However, he always talked about art.

We also liked his early associate, Windham Hannaway, one of the original "cosmic messengers" from the hippie era. He would show up in New York unexpectedly, have long talks throughout the night, fall asleep on the floor for a while and by sunrise be gone. —W.V.

GLEN SOUTHWORTH WAS educated in engineering at the University of Idaho and in the U.S. Army Southeastern School. He is Chairman and Treasurer of Colorado Video, Inc. in Boulder, Colorado where he lives with his wife and three children. He received numerous awards including the National Academy of Television Arts & Sciences Engineering Award in 1990. Southworth holds significant patents in the field. He was born in Moscow, Idaho in 1925.



Frame 202



INFO frame 25138 to 26585

## INSTRUMENTS FOR VIDEO ART by Colorado Video, Inc.

- \* Linear Patterns: 101, 120, 121, 122
- \* Computer Input: 201, 201A, 260
- \* Computer Output: 261A, 404A, 404D
- \* Hard Copy: 302-5
- \* Video Discs: 401A, 410
- \* Camera: 502
- \* Split Screen: 603
- \* Grey Scale Modification: 604
- \* Color Synthesis: 606, 606A, 606C
- \* Shading: 608
- \* Markers: 601C, 621

Paper and pencil are wonderful inventions, watercolors and oil are cheap. But let's look at it closely—these techniques are millenia old and we're in an electronic era. Video image creation and manipulation is fast, fascinating, and capable of effects never dreamed of by daVinci or Michelangelo.

Our business is primarily the design and manufacture of video instruments for research laboratories, but now and then we come up with a device that is sheer fun. Maybe we'll start a new division someday. But in the meantime, we enjoy talking to artists (engineers and scientists, too).

*(continued)*



Left: Glen Southworth, inventor and founder of CVI/ Colorado Video, Inc. Self Portrait with first experiments on direct CRT copying with original XEROX color machine.

Below: CVI Video Quantizer, 1969. Collection of ETC, Ltd. & The State University of New York, Binghamton.

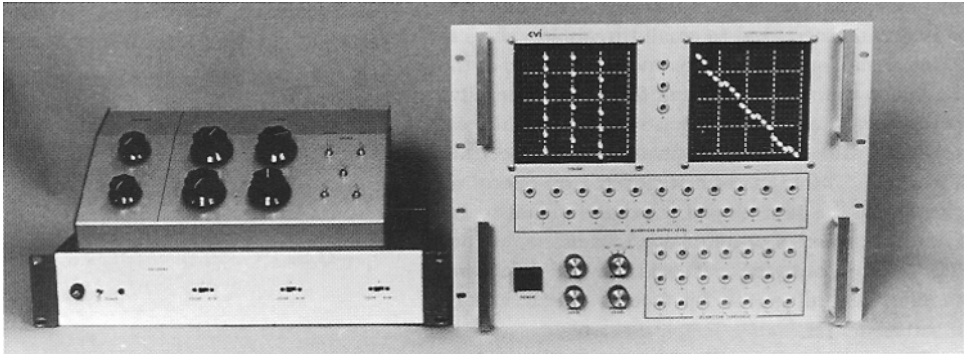

CVI Data Camera, 1970. Collection of ETC, Ltd. & The State University of New York, Binghamton.

## ABSTRACT PATTERN GENERATION VIA TELEVISION TECHNIQUES

A number of interesting and aesthetically pleasing patterns may be produced on a television screen in black and white or in color by pointing the lens of a television camera at the monitor screen. With a standard, unmodified television camera, this would result in an image similar to that produced by two parallel mirrors, with duplication of the image seen to infinity, depending upon the camera angle and proximity.

By introducing certain distortions in the video signal before it is applied to the television monitor, a much wider variety of interesting and pleasing effects may be achieved. The basic operation involved is the translation of the continuous range of grey scale values from the television camera output to a black or white only signal through means of a device such as a high-speed Schmitt trigger. In this instance, the sensitivity of the television camera is very greatly increased to small threshold values of video signal, and when the camera is pointed at the television monitor, a different form of regenerative process can take place when monitor brightness, contrast, and camera sensitivity exceed a certain threshold. The high gain of closed-loop operation can cause the reproduced television signal to assume a number of unusual configurations, including slowly changing patterns on the television monitor as influenced by factors which will be discussed later.

Two or more Schmitt triggers or slicers set to different amplitude levels will generate more complex patterns, and the outputs of such slicers or quantizers can be fed to the inputs of a color television monitor or color encoder or produce colored images. Color greatly enhances the beauty of the patterns. A block diagram of a typical system, usable with either black and white or color, is shown on the other side.

Pattern generation is influenced by the following factors:

- 1) Camera distance and lens focal length as compared to the diameter of the picture monitor.
- 2) Angle of the camera position as related to the monitor screen.
- 3) Angular rotation of the camera scanning plane.
- 4) Optical and/or electrical focus of the television camera.

- 5) Lens aperture and/or video gain of the camera.
- 6) Setting of the quantizer thresholds.
- 7) Introduction of secondary light patterns on the television monitor screen by optical means.
- 8) Introduction of secondary video images on the monitor screen through electronic mixing.
- 9) Modulation of the feedback path by external signals such as might be derived from an audio source (music, speech, etc.) as applied to any element in the chain, including brightness modulation of the television monitor screen, changes in gain of the television camera, changes in quantizer threshold levels, etc.
- 10) Utilization of vidicon or other camera pickup tubes having substantial target "lag" characteristics which tend to produce more slowly changing patterns.
- 11) Secondary modulation techniques involving variations in color intensity or hue shift.

The Colorado Video Models 606, 606A, and 606C Video Quantizers may be used to create the above effects. The 606 incorporates 16 slicing channels, the 606A 8 channels, and the 606C 21. All units have provision for very flexible programming, including interaction between slicing channels.

—G.S.

### VIDEO QUANTIZER

The CVI Model 606C Video Quantizer is a commercial example of a threshold based colorizer. It processes a monochrome video signal to "achieve radical alterations in output linearity or . . . synthesize color signals from different shades of grey" (From the CVI 606C manual). It identifies intensity regions and then displays them in color to make them more visible. X-ray, medical and thermal analysis are some examples where regions are tinted with color to reveal swollen bone tissue or heat emissions.

The input is a monochrome video signal that is "thresholded" into 21 grey regions and "level sliced" by a bank of comparators. The outputs of the "grey slice" generators are run to gain control potentiometers that route to a patch panel, for assignment to Red, Green and Blue levels. A "key" patch panel is used to assign the overlap of colored regions and to isolate the interaction between quantized regions. A quantized region can be patched to KEY OFF or inhibit other regions. Without "key inhibition" the intensity of a region's dialed RGB values will add together. A monochrome mix is formed through using equal values of Red, Green and Blue. This allows the superimposition of color into the grey contours of a black and white image. — J.S.

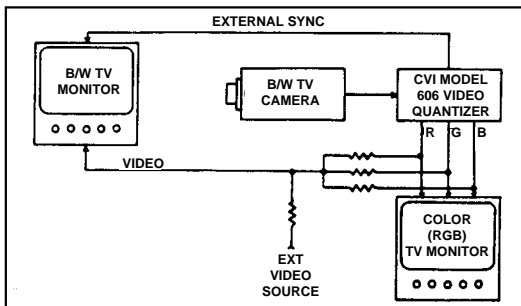

### THE CVI DATA CAMERA

Colorado Video Inc (CVI), founded by Glenn Southworth, developed an externally lockable video camera called the CVI 502 Data Camera. It contained a one inch pickup tube and was intended for use in laboratory research and the scanning of non-standard video formats. To permit operation with slow scan television, provision was made for external horizontal and vertical sweep signals and a beam blanking signal.

CVI had foreseen unusual scan patterns for driving the camera deflection yokes: radial, circular as well as pseudo-random patterns. The unusual scan patterns are formed by externally supplied sweep signals, to deflect the camera image beam. By modulating the sweep signals with analog processing modules, the inverse of a CRT based scan processor is formed. The camera scan processor has the advantage of directly developing the intensity information from the surface of the camera tube, without having to re-scan the modified raster off a CRT screen.

The camera can be pointed at graphics or images while it's horizontal and vertical ramp signals are modulated. No matter how crazy or distorted the sweep patterns that drive the camera, the resulting output is a monochrome video signal. An external sync adder is used to convert the camera intensity into a composite video signal. External H and V drives are supplied to form a signal to blank the camera tube. The adjustment of Focus, Beam, Target, Horizontal and Vertical Center controls are through knobs placed on the Camera Control Unit. The video gain can be externally voltage controlled or corrected with the twist of a knob.

A disadvantage of the camera scan processor method is that the source image must be present for pickup, otherwise the desired source image is "re-scanned" with the data camera pointed at a monitor driven from a video tape. Correction of shading error, reduced brightness in small scanned areas,

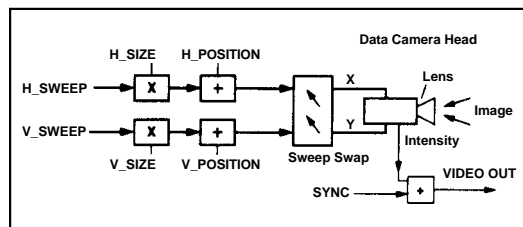

and beam protection to prevent "burning" the pickup tube surface, requires circuitry external to the data camera.

# ERIC SIEGEL

**EVS Electronic Video Synthesizer (Analog), 1970**  
**Dual Colorizer (Analog), 1971**

ONE OF THE MOST UNUSUAL personalities amongst the builders was Eric Siegel. Eric was flying on those undefinable wings of youthful divinity, propped up by willing muses. True, his art involvement was brief, and he soon lapsed into relative obscurity. A serious search found him again twenty years later.

From the child genius building electric boxes, to the socially engaged utopian reformer, from a self-educated dyslexic to an overland traveller from Europe to India, he had a keen sense of opportunity. In no time he initiated and organized a group with two of us called "The Perception". Howard Wise was the umbrella and it went on feeding other artists long after we departed to organize The Kitchen.

Our infatuation with Eric was probably conditioned by our coming from Europe. Europeans have always been perplexed by the unexplainable source of American talent: something springing up from nowhere without history, right in the belly of the beast of capitalism.

I always wonder why it took Eric to introduce this new image so convincingly. Something extraordinary happened when we saw that flaming face of Einstein at the end of the corridor. For us, something ominous, for me, something finally free of film. —W.V.

ONE OF THE EARLY adventurers into the realm of video, Eric Siegel was born in New York in 1944. He failed the electronics course in high school but went on to invent the PCS (Processing Chrominance Synthesizer) in 1968 which permits controlled colorizing of black and white videotapes and the EVS (Electronic Video Synthesizer) in 1970, by means of which abstract forms, mostly geometrical, can be created at will in color on a TV screen without the use of a camera. The "Einstein" tape, 1968, uses video feedback to produce its psychedelic effects, and was one of the first video art tapes to use this technique. Siegel spent half a year in India, studying Hindu medicine and making videotapes.

A FEW WORDS *from an interview by Jud Yalkut.*

E.S.: For the last two years, out of necessity, I've been into a hardware trip, and in this time I've developed two pieces of video equipment, both of which were developed in San Francisco. I thought that I would work better out there. The main projects was the Electronic Video Synthesizer, that's like the video equivalent of a music synthesizer, where you have a program board and you can start to set up a whole series of visual geometric happenings in color on the video signals—the screen—and this is designed for video compositions. At the Kitchen last week (in 1973), I did a piece called Yantra Mantra with it, which was quite favorably received. The other piece of equipment is the colorizer. There have been, by the way, business and technical snags to getting out the EVS, but it is something that people should be able to go out and get. On the EVS, you just have to put in sync, and everything is composed right inside of the synthesizer. But you can put in live cameras too, and do things that involve pictures and synthesizer images.

So that's the EVS, and the other piece of equipment I've been developing parallel to this is the Color Synthesizer, or Video Colorizer, as people tend to



Frame 086 step through next 3 frames



STEP BACK



STEP FORWARD



Above: Eric Siegel, 1971, from a video tape made at the Howard Wise Gallery, New York City.  
Right: EVS (Electronic Video Synthesizer), 1970

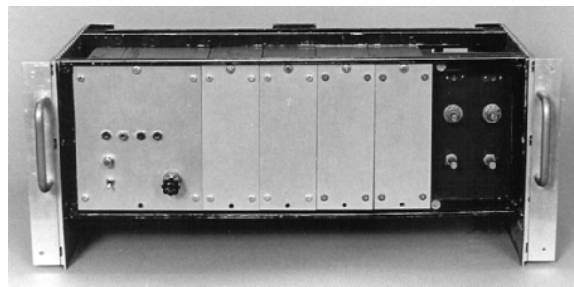
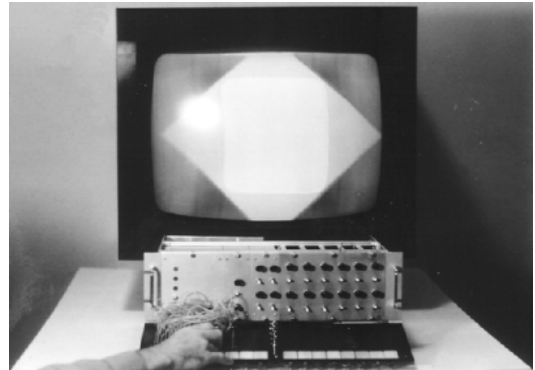

Dual Colorizer, 1972

want to call it. That takes black and white video signals, from 1/2" tape, like people who have been shooting with their portapaks, and it allows them to synthetically color the picture. This doesn't work out well for interviews or straight types of photography but it does work out extremely well when you move into the more visual and abstract things. And I found it also works out well with shots of natural mountains, sky, water, trees, nature, things like that colorize very well.

*What do you think can be done to improve video as a healing technique? To improve the vibrational food that people get from it.*

I think that depends wholly on the particular video artist who produced the video, they have to expand themselves, they have to go to the top of the mountain first, and then through their tapes show everyone else the top of the mountain. I haven't met too

many who have gotten to the top at all yet.

*And also, as they say in Zen, when one goes to the top of the mountain, after achieving nothing, one must return to the marketplace. . . . Wasn't there, by the way, an earlier version of the colorizer?*

There were a few earlier versions, as a matter of fact. I would put it another way: it has been under constant development and has gotten to a stage now where I am totally satisfied with the way it works. You see, all the previous ones that I made and that other people have made have many problem areas; you couldn't get the colors clean, within the areas and the borders; they would always bleed into the next things and smear and oscillate.

*Some people did like that effect and still do.*

Yes, there are some people who want this wild type of smeary effect, but I don't. I don't dig it at all, and

electronically, it is totally inaccurate, and I don't even agree with the aesthetics of it. So, the way mine is right now, the colors are very clean and totally within their borders and areas. At times it looks like chromakey, where you see two pictures cut in so neatly and cleanly that you're convinced that it is one picture.

*Can we consider the synthesizer as a tool for the transmission of energy?*

Karma energy, in the logic sense. I think the synthesizer will enable Western man to take advantage of the technology that he has created and only put it to the use of pro-life, pro-spiritual powers. I think that the synthesizer, used by people who have advanced to higher levels of consciousness, whatever you wish to call them, can be used in that way so that this can rub off to an extent onto the people at home watching it.

*We mentioned earlier the possibility of having an interface between "electronic gurus" as we'll call them, who can speak through this transmission to each other, creating perhaps an energy field which is capable of enveloping a larger number of people.*

Hopefully, yes. If this should continue, perhaps with the energy that is transmitted being received by other video gurus, so to speak, they would pick up on that and send a new flow of more concentrated energy back out into the airwaves once again, and start not an atomic chain reaction, but a psychic chain reaction.

*A psychic chain reaction which in this case is being initiated totally by electronic means, by the direct electronic interpolation of the performer-guru in reaction to his external and internal environments.*

E.S. Right. In other words, video, because there is this portable equipment, because it is being used to make this segment which will go out on the air now. Because there is this equipment, it means that you don't have to make videotapes in the environment that we're making them in now, and we're only isolated from the horror city by hundreds of feet

(Note: this interview was conducted in Central Park.) and so the karma of New York City is still upon us, and we can't escape that, and it will come through on this tape. But this recorder that we're using can be taken out where there is good karma to make recordings, and then the tapes can be sent to places like New York where there's bad karma, and good karma can be transmitted through the airwaves.

*The synthesizer, too, is also basically a portable piece of equipment and can be used to broadcast quality transmission, or for 1/2," or for any type of equipment.*

Yes, and as a matter of fact, it can be run on batteries. You can take a battery-powered tape recorder, a sync generator, and a video synthesizer, go up to the top of a mountain and do it. I think that technology is finally going to go into its second phase of existence—to help mankind, not for war.

The Electronic Video Synthesizer was created to enhance the interface between the Video artist and the people. Each human being is enshelled in his own perception of reality. Rational logical communications have their severe limitations. The communications which take place on the aesthetic abstract level deal with the inner tune of a being. It's like the DNA code of the artist speaking to the world. Since we all perceive different worlds, in the same worlds, it becomes our necessity to find witnesses, when we find the ultimate witness . . . we find love. The current trend towards religion and God is in a way a frustrated attempt to find the ultimate witness. One can not do without a witness. What you see on the screen is my attempt to get a witness deeper into your being. —Eric Siegel, 1973

**Howard Wise was advancing** a lot of money, he claims that it was a total of \$20,000 — I can only take him at his word— but my fingers never touched \$20,000. So there was this stress and strain of "c'mon, you've been funded, are there any results?" And at the end I felt that I'd been driven. I didn't feel good any more. But I did finish



# Siegel Video Systems

## S.V.S.

*I wish to make it public knowledge that I have just developed the first all electronic video synthesizer in the world. It is called the Electronic Video Synthesizer (E.V.S.) and it makes pictures electronically. It is an instrument for the Creation of Color Visual information in the medium of video with the possibilities of at least one thousand different pattern variations. The unit can be performed on the air live.*

*It could also be used in a video tape session involving music for the creation of mythical trips. The colors are the most intense ever seen on any T.V. or monitor before. The E.V.S. does not have a B.L.D. (Brightness level distortion; problem.*

**\*Note: BLD (Brightness level distortion) shows itself as incorrect brightness level on the video screen. Usually apparent in dark scans, showing up as a washed out grey.**

*It is the instrument of the New Television; the growing tendency of more artistic abstract*

*television performed by beautiful enchanting people. Where conventional television seeks to inform and entertain the New Television will be engaged in expanding people's consciousness and providing a way for constructive meditation.*

*The E.V.S. hypnotizes you and the person playing it controls your trip. So the way you see the E.V.S. will depend on who is playing it. "It's the singer not the song."*

*This is the second instrument in the Siegel Video System. The first is the Video Chrominance Synthesizer which converts the gray scale of a monochrome video signal into a full color chrominance signal. A more detailed discription will be issued at a later time.*

**For inquiries, write to: Eric Siegel, c/o Howard Wise Gallery, 2 West 13th Street, Rm. 1011, New York, New York 10011, Tel: (212) 989-2316.**

**SOUND** A **sound** is composed of a basic frequency (cycles per second) A **sound (or electromagnetic) source** emanates from a point in a directional pattern characteristic of its frequency. The higher a frequency is the more directional it is. **Cosmic rays**, another form of electromagnetic energy, with a very high frequency, are highly directional. **Sound waves** are relatively low in directionality, however the effect of higher frequencies equaling higher directionality is still very apparent. Sound such as a yell or ticking of a clock are much more directional than the rumble of a trailer truck which is felt and has a larger sphere of physical stimulation. (Cosmic rays are attributed with the ability to change genetic structure)

**Ideal Microphone**—a piece of flat solid material which vibrates at the same frequency and intensity (a loud sound has more punch) as the sound source. This [plate] is connected to an electronic circuit where the variation in plate movements are transduced into a variation in the flow of electrons. This energy flow is measured in volts, amperes and db.

Good simple microphone techniques consists of getting as close to the sound you want recorded and making sure the mike is pointed at the sound source especially if the microphone has a directional (cardioid) sensitivity pattern.

**RADICAL SOFTWARE**

THESE TWO PIECES WERE OMITTED FROM ISSUE THREE.

it. Then I had to go back to NYC with the finished synthesizer and Howard Wise had some shows. I don't want to go into that because it was bad for me. I was placed in a show but it was not clear to me what was going on. So that was one of the exposures of the Video Synthesizer. It sat in one of Howard Wise's offices but what I had accomplished with it was elementary. It demonstrated to people that a video synthesizer was a viable piece of technology but I had not been to the point where I created an art work. I really wanted to create moving mandalas like you can see from India. The motivation for the synthesizer was to alter states of consciousness. I did a few things with it but I lost interest in the Video Synthesizer because it turned into a job."

Eric Siegel

January 21, 1992

San Diego, California

### ERIC SIEGEL COLORIZER

The Eric Siegel Colorizer is a modulation based colorizer that generates color images from monochrome sources by adding a modulated subcarrier onto a black and white video signal. It is a derivative of a Video Processing Amplifier (Proc Amp) whose primary function is to cleanse the composite video of signal aberrations. The Proc Amp re-inserts the sync signal, adjusts the brightness, contrast (gain) and edge enhancement of the luminance component, while correcting the hue (phase) and saturation (amplitude) of the chrominance component. The Siegel colorizer modifies the functions of a Proc Amp by generating a synthetic subcarrier. It is then

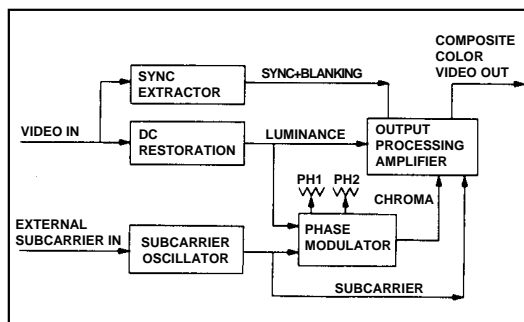

added to the luminance component of the input source which forms color from a black and white picture. The black to white excursions of the input signal shift the color hue. This generates multitudes of colors that track the brightness of the video.

A monochrome input signal is filtered of extraneous 3.58 MHZ components then detail enhanced and run to a Chroma Phase Shift Modulator. The modulator links the video brightness to a phase shift of the synthetic color subcarrier, swinging it's output hue. The two stage phase shift circuit enables greater than 360 degree rotations in hue space, or "Ultra-Phase Modulation" of the chroma. The degree of phase shift and its polarity are selected through the front panel. The starting hue and saturation of the synthetic chroma, along with brightness and contrast of the output video, are adjusted through front panel controls.

### ERIC SIEGEL EVS SYNTHESIZER

The EVS Video synthesizer contains many components of the Special Effects Generator (SEG), with the additions of a color encoder and free form patch matrix. Built in a BIC-VERO rack with front panel knobs and switches, a large horizontal plug matrix is present to patch together video effects. The patch panels were pulled from IBM style card sorters, with connections formed by mini-banana plug cables in a rainbow of adorable colors. In the front of the patch panels is a row of 16 white, flat rocker switches, arranged horizontally to resemble a piano keyboard. The matrix has 15 rows by 20 columns with various inputs and outputs scattered throughout the panel. The processing connections are carried back to the main rack unit. All voltages at the patch matrix are 1 Volt P-P, allowing for the connection of any output to any input. The outputs of the modules are low impedance and can drive multiple inputs. The synthesizer box has provisions for two video input sources, and a duplicate set of video outputs.

In the rack of electronics sits:

- 1) A power supply for the modules
- 2) Three voltage controlled *two-in-one-out* video mixers. These can switch at video rates, as well as mix the two video inputs depending on the control signal input.
- 3) A Horizontally and a Vertically locked sawtooth generator with a square and logarithmic waveform

output. These can be used to form horizontal or vertical patterns for use as a video or control source. The oscillators can be independently voltage controlled and “unlocked” to the horizontal or vertical timing source, causing the patterns to “wobble” horizontally or vertically.

4) A Horizontally and Vertically locked triangle/square waveform generator with logical combinations of the H and V patterns. This forms 4 basic patterns : a Horizontal bar, a Vertical bar, a square pattern formed from the “Anding” of the H and V bars, and a diamond pattern formed from the gating of the H and V triangle waveforms. All four outputs are available simultaneously at the patch panel. Size and position of the triangle/bars is controlled from knobs on the front panel.

5) Dual voltage controlled oscillator/generators with dual video attenuators. The voltage controlled oscillators can free-run or be locked to horizontal or vertical sync. The frequency of oscillation is selected through a rotary switch to switch the capacitive time constant. The video attenuators linearly attenuate from input to output, in response to the control input.

6) The output color encoder. The main color encoder of the Siegel colorizer is contained here. It is a conventional “doubly balanced modulator” to perform the hue and saturation generation from the control inputs. In place of a conventional R-Y and B-Y inputs, dual inputs are present on both modulators for inverting and non-inverting phase shifts. The first modulator axis is adjusted for orientation along the Red / Cyan axis, while the second modulator is set 90 degrees in quadrature on the Green / Magenta color axis. The modulator’s outputs are summed together and form the chrominance signal. The chroma along with the color burst is run to the output Proc Amp for combination, to form a composite color video signal.

The substitution of luminance video with and without waveform modulation helps to generate the unusual colorizing, with the hue and saturation changes determined by the horizontal components of the controlling waveforms. The overdriving of the

dual modulators with video signals has been described by Eric Siegel as “Ultra-Phase Modulation.”

7) The output of the colorizer goes to the Processing amplifier. The output Proc Amp merges and cleans up (blanks) the synthesized video to a form that is video compatible. It is here that the burst, sync and blanking is formed and gated, and the luminance and chrominance combined. Knobs are available to mix the Luma and Chroma proportions for the two main video output. — J.S.

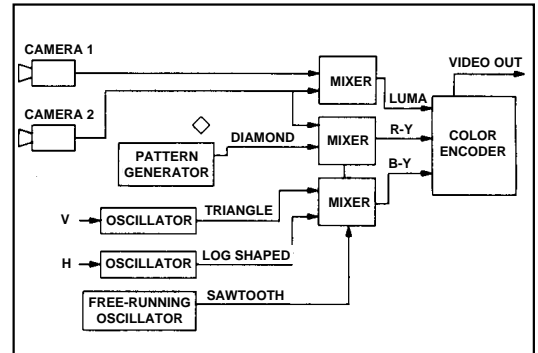

# STEPHEN BECK

**Direct Video Synthesizer (Analog), 1970**

**Beck Video Weaver (Digital), 1974**

IN THE SUMMER OF 1971 we went to San Francisco on an invitation from Paul Kaufman. The days were cold and we often drove over the bay to Mount Diablo to warm our bones. The National Center for Experiments in Television was in a state of disintegration and there were bitter feelings about things we did not understand.

There were two instruments we were eager to explore: "The Bench" and Beck's DVS. The Bench appeared to us a monstrous labyrinth, months away from a conquest. It had many knobs and joysticks, many ways to alter or combine images. For us it qualified as a synthetic provider, something to be avoided. We were in our analytic phase and Beck's device appeared much more tempting, much more mysterious. The label itself had a nicely provocative slant: Direct Video Synthesizer.

Although not long lasting, there was a period in video when the subject of representation was discussed, resembling the dialog between musique concrete and the Synthesizer or the Bazenian discourse of filmic reality. The appropriation of images was the topic, those taken from God/Nature through the camera versus those constructed inside the instrument. There was a clear interest in machine-made forms as far away from nature as possible. The synthetic principle was the talk of the day.

Beck also presented a rather scholastic theory of synthetic pictorialism, something he later meticulously explained in his didactic tape. Although we got inspired by Beck in general, we never got to touch his instrument. Nevertheless, the tool pool there was an enlightened one. Besides the specialized video gear, there was a Buchla box, well suited for controlling video. "The Bench", constructed by Larry Templeton, produced numerous works mostly by Roarty, Gwin and Hallock. "Painting in time" was how they used to describe the process.

Whatever the original agenda might have been, here was a group of people who defined a highly personalized and unique pictorial style, something quite incompatible with the interests of a broadcast station (KQED). —W.V.

BECK HOLDS A DEGREE in electrical engineering from the University of California, Berkeley, and also studied at the University of Illinois, Urbana in electronics and electronic music. He constructed his first direct video synthesizer in 1969, and another synthesizer while affiliated with the National Center for Experiments in Television, San Francisco. His videographic work includes many compositions realized with the Direct Video Synthesizer on video tape, in live performance, and videofilms. Presently he works from a studio in Berkeley, California, where he founded Beck-Tech Corporation as a microelectronic product research and development company. He was born in 1950 in Chicago Illinois.

"I WENT TO SCHOOL at the University of Illinois and was very fortunate to find the experimental music studio in Champagne/Urbana. They were looking for somebody to wire things together and I got the job. The University of Illinois was a very happening place in the late sixties because of Lejaren Hiller, Herbert Brün and a technical guy named James Beauchamp who was actually an electrical engineer. That was in 1968. We had one of the first Moog synthesizers and we had built something called the Harmonic Tone Generator. Sal Martirano was one of the most progressive and daring of the music faculty and was very kind to all of the students who showed any interest at all. He'd invite them into his home and we'd sit around and

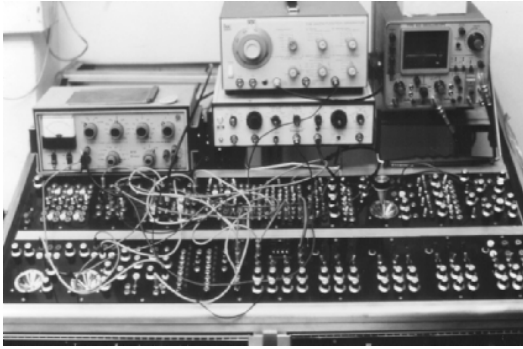

Direct Video Synthesizer



The Beck Video Weaver, and the maniac himself, Stephen Beck.

have discussions and play music. I admired him immensely because he took it upon himself in his middle age to learn electronics, circuit theory, and digital logic in order to progress his art.

At the time there was a lot of experimentation with consciousness altering substances such as cannabis, LSD-25, mescaline and shamanic rituals. We'd get together to chant and induce visions and hallucinations. This all fascinated me because for as long as I could remember I'd always seen lots of images when I closed my eyes which I later learned were called phosphenes and hypnogogic, hypnopompic, eidetic imagery.

I started to design conceptual circuits that would go beyond the oscilloscope and vector display. My perception at that time was that here was this incredible technology of color television, which I understood thoroughly at the technical level, which just cried out to be used for some higher purpose. There was also at that time a tremendous amount of resistance against the war in Vietnam. All of us were in danger of being drafted and we were protesting. There was this incredible opposition to what I saw as technological genocide. Here was this technology and people hated it because it was so destructive and at the same time, that technology was being used to go to space. That was the positive manifestation of that technology.

I was studying electrical engineering and I was kind of an apologist or promoter of that positive aspect of technology. I always wanted to make something beautiful out of television as my premise. I was making oscilloscope movies in the electronic

music studio and Ron Namath filmed some of them. Sal Martirano saw what I was doing and he was really enthusiastic and he asked me to start performing with him. I would go to his house with other students and we'd design gates and digital circuits and try to wire them up. It was this huge construction with thousands of patchwires.

I arrived at KQED in August of 1970 and immediately started ordering equipment to build a synthesizer. I met Richard Felciano and we started collaborating on some studies using the Buchla Synthesizer and my machine. I had designed my voltage range inputs to be compatible with the Buchla Synthesizer thinking, I'll go look Buchla up and maybe we can team up and make something. I started to produce imagery and also it was my first opportunity to work with videotape." —S.B.

#### DIRECT VIDEO SYNTHESIZER (ZERO AND ONE)

The first Beck video synthesizer was later called Direct Video Zero. Direct Video #0 (DV #0) was an expansion of Beck's Illinois experiments, consisting of a modified color television set, with modulation sources driving the color CRT's red, green and blue electron guns. Colors were formed from oscillators and audio signals combined with external analog mixers. The modulation sources were pulled from a Buchla Electronic Music synthesizer to visualize sound. These color images were named "Direct Video" by Brice Howard, director of NCET.

The difficulty of using audio that "sounds good"



to form an image that "looks good" was problematic in DV #0. The most interesting images were found from sound sources which were harmonically related to the vertical field rate (60 HZ) and/or the horizontal rate (15,750 KHZ), frequencies not common to audio synthesizers. The search for dedicated sources of video patterns, and a grant from the National Endowment for the Arts in 1971 evolved into the Direct Video Instrument One (DV #1).

The central element of DV #1 to generate the "direct video" image was called by Beck a "voltage to position converter". The converter was loosely based upon a "wipe generator" of a conventional video switcher. The wipe generator consists of a horizontal and vertical locked ramp generator locked to the horizontal and vertical sync. The ramps are compared against "wipe voltages" from knobs to determine the size and position of a switching signal that appears to "wipe" one image over another. The wipe circuitry was modified, replacing the knobs with voltage control of its operation. An input voltage changes the size and/or position of the waveforms triggered by the comparison point along the horizontal or vertical axis. DV #1 modularized this converter, then added an edge extracting "Outliner" that was wired to binary logic gates. The combined signals were patched into multiple color voltages summed together to feed an RGB to NTSC Color Encoder. The use of the NTSC encoder replaced "driving the guns" of the CRT in DV#0, and enabled the results to be recorded on video tape. DV #1 was constructed in a rack mount chassis with two rows of modules and patch cables formed from 1/8" mini-phono plug cables. The modules include:

- 1) Two dual axis joystick controls
- 2) A Horizontal and Vertical Ramp generator
- 3) A H or V phase-locked voltage controlled oscillator generating a triangle and square wave output. Non-linear waveshaping was later added.
- 4) Eight Voltage to Position Converters - switch selected on H or V, to generate rectangular pulses. These pulses are controlled in position and width under voltage control. Output of these modules are gated together in the binary "geometric region processor".
- 5) An array of binary functions called an "octal geometric region processor." A collection of eight digital functions of two signals: A and B, A or B, A EXOR B, are used to combine the rectangular pulses formed by the Voltage to Position Converter

modules.

6) A Video Outliner called a "geometric unit generator" generates lines and points. The outliner has a horizontal edge extractor formed through delay of the video signal, and "EXOR-ed" with itself.

The extracted left and right edges is selected to pick off the leading or trailing edges of the image. These horizontally derived edges trigger a 1-8 line "monostable" to form a rough approximation of vertical edge.

7) A Dual Video Processor - with gain and a "threshold control", to "core" out, and truncate video signals below a certain level. The processor can alternately be used as a level converter to translate audio signals to DV#1 levels. This concession allows camera images to enter the direct video data path.

8) One Quad Mixer module - with 11 input patch connectors. Four front panel thumbwheel switches assign the patched signals from the pattern generators to one of the four color channels labeled A,B,C and D. Each of the four channels has a "gate" input to "turn-to-black" or turn off the signal with a video speed control voltage. Switch #0 is connected to a flat color field, switch #9 and #10 are hard-wired for the two external camera inputs of the Dual Processor. Each of the four channels has a low pass filter to smear the image, called a "texture generator" and can be set to either a horizontal or vertical time constant. Each of the four outputs drive a master level control which wires over to the Color Chord modules.

9) Four Color Chord modules - These modules superimpose the Quad Mixer output into triplets of red, green and blue levels which drive amplifiers with non-inverting and inverting inputs. Each module is controlled by its own set of six knobs, the superposition of the signals appearing as "color

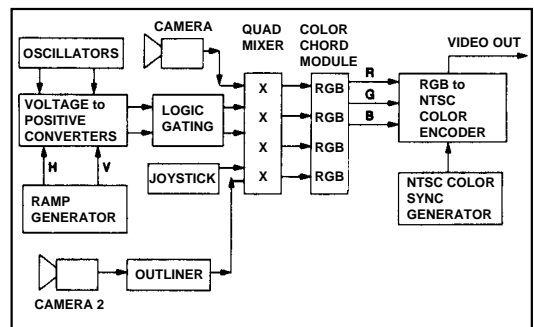

chords". Three knobs are assigned to the non-inverting Red, Green and Blue amplifiers, and three other knobs to the inverting or "negative" side of these differential output amplifiers. The amplifier outputs are DC restored then passed along for final output to the RGB to NTSC Encoder. A 3M NTSC color encoder and Telemation NTSC color sync generator develops the timing and final video output for DV #1. A simultaneous monochrome and color video output are available.

## VIDEO WEAVER

The Video Weaver is a digital pattern generator involving a string of counters and a Random Access Memory (RAM) to hold and later retrieve a stored pattern. It can be viewed as an electronic loom, having a vertical warp and a horizontal weft. The pattern is programmed into the memory then "woven" onto the screen by a set of phase shifting counters that slide and shift their count sequence in time to the video raster. A cursor is available to write in the pattern, while various phasing and counter direction parameters are used to offset the scanning order of the resulting video pattern. It differs from a strict frame buffer design in that the counters that read the memory are not locked into a static scanning order, but drift and wrap-around as the raster progresses.

The 1K by 1 bit static RAM memory stores patterns that are entered in an orderly or randomized sequence, with data locations pointed to by a "write cursor". The cursor is a Point or "cross-hair" that is locked horizontally and vertically, with a pushbutton that enables the entry of data. Timing, sync and the output colorizer were borrowed from the DV#1. The cursor timing was pulled from the Voltage-to-Position-Converter, and adjusted with a joystick. Later design of a digital cursor allowed for stable, and repeatable positioning.

A set of three "cascaded" 4 bit counters are arranged so that a first counter (C) feeds a second (B), which feeds a third (A). The end counter (A) is clocked at the subcarrier rate and loaded from the second counter (B) at each horizontal sync pulse. The second counter advances at the horizontal rate and is loaded from the first counter (C) every vertical interval. Each of the three counters has its clock

input routed through a clock divider. The output of these two end counters (A and B) form an 8 bit address to access the pattern stored in memory. The front counter counts an elapsed frame count and controls the speed of the pattern. Four banks of patterns are stored in the pattern memory. This sequence of wrapping address counters causes a pattern of harmonic rich images. The use of the subcarrier as a horizontal clock generates a staggering line position adding texture to the image.

The pattern memory output, along with selected memory address bits, are combined and converted into a composite color video signal in the DV#1, using the Quad mixer and Color Chord modules. The Weaver was used as an image source for video tapes made by Beck, while his experiments in pattern storage and display formed the basis for his later design work in video games. —J.S.

\*\*\*

**THE VIDEO WEAVER** has been "reincarnated" in 1992 specially for the Ars Electronica "Pioneers of Electronic Art" exhibition. The reincarnation implements the original 1974 digital design within two ASIC chips that replace the 60 original 7400 series TTL logic chips. The functionality is the same. The new Video Weaver implementation utilizes PLCA chips, programmable logic cell arrays, to include all counters and logic within a single CMOS gate array of 3000 gates. The user control and interaction is via manual switches and patching. (Engineering of the new LCA is by Stephen Beck, with the assistance of Kevin Fischer and Dave Barr. Additional assembly by Bob Vanegas.) —S.B.

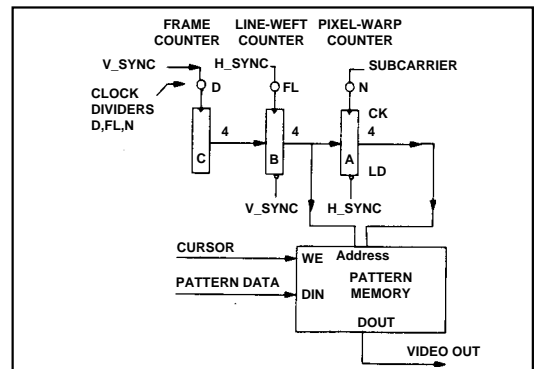

INFO frame 10559 to 11299



NANO B frame 6956 to 27354

# NAM JUNE PAIK & SHUYA ABE

Paik / Abe Video Synthesizer (Keyer & Colorizer)  
& Scan Modulator (a.k.a. "the Wobbulator"), 1970

WITH THE PASSAGE of time, the understanding of Paik does not get easier. In our own time slit, his presence assumes a lonely and therefore much larger proportion. His work in the Sixties, luckily, is the most relevant for our show. As a practitioner looking back on that period, I realize (maybe for the first time) the scope of the homework he has done. Once you get over his early Fluxus furniture pieces, there is a naked man with his metaphysical struggle. There is a testimony and revelation of many principles and the materials to come. Even after he could afford all the help he could buy, a substantial body of work, experiments, manifestos and personal interventions remains for all of us to see! —W.V.

NAM JUNE PAIK WAS BORN in 1932 in Seoul, Korea. He graduated in 1956 from the University of Tokyo, Japan. Studies in music, art history, and philosophy were subsequently pursued from 1956 to 1958 at the University of Munich, Freiburg Conservatory and the University of Cologne. From 1958 to 1961 he worked at the Studio for Electronic Music of Radio Cologne. Paik is without a doubt the most famous living video artist. He lives in New York City.

BINGHAMTON LETTER  
nam june paik, 1972 Jan, 8

Dear friends at Radical Software:  
Westerners pretend to be younger than their age . . . we Asians often pretend to look older . . . My mother used to say, "I cannot wear such thing . . . it would look too young." People compliment to Bucky Fuller . . . he is only 70 years young . . . Koreans express "I have *eaten* 40 years, or so." John Cage, who has out-asianized himself more than any Asians . . . certainly more than power-conscious Indian politicians, prestige-conscious Chinese cadres, GNP conscious Japanese businessmen, and super-chauvinistic Koreans . . . (is it not about time for Hippies to quit their Pseudo-Hindu cult?) . . . has managed to pretend to be older than his age.

## COMMERCIAL BREAK, NO.1

Nam June Paik is making a tribute to John Cage (a non documentary) for WGBH (with David Atwood) for John Cage's 60th birthday.

Now *video* makes our *Time* consciousness

radically different. Between the 20's and the 30's there is a gulf, a huge demarcation line more striking than the turn of the century line. It is more like A.D. and B.C. in the christian calendar. The 1930's is alive everyday in our home screen as late late shows, and it will be so for centuries to come . . . where as 1920's is gone and gone . . . with wind but without video. While watching many mediocre paintings of the 17th century at Reij's Museum at Amsterdam, I suddenly realized that minor master's still-life and landscape were not an artwork but merely a visual environment of that day . . . and so is our daytime shows and latenight talkshows . . . We don't watch them . . . they are just there

. . . . TV to live with . . .

## COMMERCIAL BREAK NO. 2

Some cable or public TV should air "TV to sleep with" . . . What comes after waterbed??? Video-bed.

Ralph Hocking and I are making a video-bed to sleep on.

The word "history" came into being, because our events were *told* and *written down* thereafter. Now history is being recorded in image or video. Therefore from now on there is no more "History," but only "Imagery" or "Videory." Eg: University should change their course name from "Contemporary American History" to "Contemporary American Videory."

White snow at Binghamton made me nostalgic about cold cold night snow at Rose Art Museum (1970), when Phyllis Gershuny, very tall and pregnant, first told me about "videonewsletter," which she started with you . . . few people took it





Shuya Abe and Nam June Paik.



seriously . . . many even did not bother to answer your questionnaires . . . but, lo, behold . . . it is now a world-famous-Radical-Software . . . Last June Phyllis Gershuny, with her baby, crawling and crying, came up to Cal Arts (L.A.) to give a lecture with full of authority. Students admired her as a revolutionary, who MADE it. It was a unforgettably beautiful scene . . . sorry, we could pay her only 30 \$ from Disney Emperium . . . I felt like a pig . . . a small one.

It is about time that somebody writes a decent review on "Vision and Television" (organized by Russel Connor at Rose Art) . . . the most important fact . . . it is the first art show, which attracted many dogs. Everyday quite a few dogs were waiting at the door to get into the museum . . . and it was not a meat-Happening à la 1960's Happening era . . . but a cold, cool video show in 1970 January . . . The reason was clear later . . . . About 100 TV sets were humming and zumming their 15,000 cycles horizontal Oscillation frequencies . . . and it is, though hardly audible to human ears, the most attractive frequency range for dog's ear. Therefore 100 TV sets at Rose Art Museum must have sounded like Beatles at Shea Stadium and Mommehd Ali at Madison Square Garden combined . . . to all unsophisticated country-dogs of Waltham, Mass.

There must be a channel for dog on Cable . . . to soothe down the irritated dog's nerve living in small Manhattan apartment . . . I will compose

many "ultrasonic lullabies" for dogs. And we will see many commercials for video cassettes for dogs, as we see of cat-food commercials.

When communication satellite enables global TV in full swing, will CBS carry cat-food commercials to hungry Bengali people?

COMMERCIAL BREAK NO. 3

John Cage comes up on the screen and says

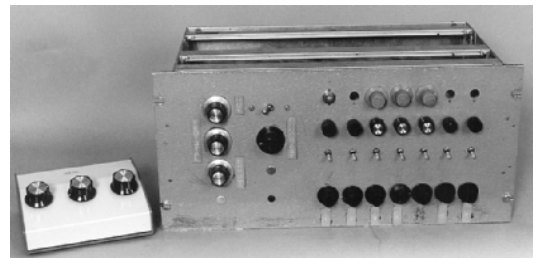

Paik/Abe Synthesizer with Interface.

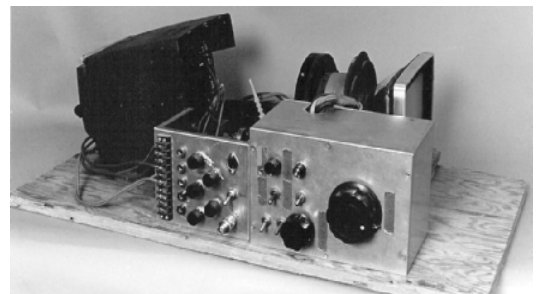

Paik/Abe Scan Modulator. Collection of ETC.

"This is the newest Pill from FLUXUS Chemical Company . . . you swallow it . . . it tastes nothing . . . smells nothings . . . and does nothing."

John refused to do it on his program.

We are hearing so much about "Broadcast standard" in video. But the more important the content is, the technical standard tends to be less perfect . . . e.g., CBS report on the dissenters in Soviet . . . and many satellite relays, which tends to lose color sync often . . . and finally MOON LANDING.

Moon landing's picture was way way below the FCC broadcast standard. Why did FCC not forbid the broadcasting of Moon landing? . . . it was a double standard. Moon landing killed so-said FCC standard in video technology for good . . . . This fact is as important as a very competent chief engineer at Cal Arts video studio.

COMMERCIAL BREAK NO. 4  
skip

Difference of the 50's liberal and 60's radical is that the former was serious and pessimistic, the latter was optimistic and loved fun. Who changed the society more??? I think the latter. John Cage's refusal to accept "Serious" continental aesthetics, and the rise of Happening, popart, Fluxusmovement signaled the beginning of the Sixties . . . . What will signal the Seventies??? needless to say . . . "video."

*Video-Videa-Vidiot-Videology.*

Currently there is a danger that video becomes like "poetry" . . . one guy writes, and only his immediate friends appreciate . . . . I don't know how many un-edited dull tapes I had to sit through politely . . . . We should be more conscious of the situation that we are in the era of information overload and it means information-retrieval is more tricky than information recording . . . . Therefore one of Binghamton experiment of Ralph Hocking, Ken Dominick, Bob Diamond, Shierry Miller is how to compete with Walter Cronkite with half inch tape??? Here I think my endeavor with video synthesizer becomes also important in seemingly pure information age.

Geisha is the oldest Time-sharing device of male chauvinism.  
Marriage is an instant Sex-access system.

Telephone is point to point communication system.

Radio-TV is a point to space communication system . . . like fish egg.

Ultimate goal of video revolution is the establishment of  
space to space, or plain to plain communication  
without confusion and interference of each other.

How to achieve this goal?

it will need decades of experiments.

Douglas Davis' Hokkaidim event at Corcoran Gallery (last June) was so far the most ambitious endeavour to touch this home base at one shot. Nobody expected a hole-in-one, but it showed vividly that our direction was right, workable . . . and many more experiments should be done toward this very end.

What is art?

Is it the moon?

or

the fingertip, which points to this moon?

Avantgarde art is the finger-tip and Hokkadim was a sharp finger-tip.

I am A Korean . . . I tend to pretend to look old . . . I am almost 39 and a half years old, still I am sloppy like hell . . . I hate perfectionist. Yukio Mishima was a "perfectionist" . . . his death was a "perfect" mistake.

COMMERCIAL BREAK NO. 5

I am selling my loft at Canal Street.  
2000 \$ fixture. 145 \$ rent.

Paul Valery wrote in the thirties that a middle class French young man can enjoy more material pleasure than Louis the fourteenth.

On the same logic, our brother in disadvantaged neighborhood can enjoy more visual pleasure than a middle class young man in the thirties . . . Nowadays anybody can see 20 movies a week, which nobody did in the thirties . . . The poorer people are, the richer is their visual life. . . .

Is it progress?

Am I a pig?

Dear Radical Software:

It is only two and half year, since we all met at Howard Wise Gallery . . . and in video calendar, it

looks like a last century. It means that we covered a huge terrain . . . Not any other discipline did so well as we did. . . it is a time for congratulation . . . For myself, I re-lived the excitement of early Sixties, when we made various Fluxus events and publication. I am deeply grateful for that . . . and I am lucky to have had the youth twice. and it is just a beginning . . . when we get "wall to wall TB," video cassettes, cable TV, 3-D color TV all ined up. . . . where will we be?

Let us live long. . . .  
as

Marcel Duchamp did.

njp

**PAIK - ABE VIDEO SYNTHESIZER**

The Paik-Abe Video synthesizer was a collaboration between Nam June Paik and video engineer Shuya Abe. The basic synthesizer is a colorizer, but in keeping with Nam June Paik's method to create a "smorgasbord of video art", a scan modulator was often found adjacent to the colorizer. Combining video feedback, magnetic scan modulation, and non-linear mixing followed by colorizing, generated its novel style of imagery.

The basic Paik-Abe is a colorizer unit with seven external video inputs and corresponding gain controls. Each of the seven inputs drive various non-linear processing amplifiers. The amplifier passes low level signals but folds over or inverts the polarity of higher level signals. High brightness components are turned into "negative" video while low brightness components can pass through without change. The output of the seven distorted amplifiers drive (depending on the version) a patch panel, a bank of switches or are "hard-wiring" to a resistive matrix. Of the seven signals, Shuya Abe believed that "Channel 6 should have the weaker signal, to maintain a sense of balance in the instrument."

The matrix adds proportions of the seven signals to the Red, Blue and Green signals that drive an RGB to NTSC color encoder. The NTSC color encoder is constructed from a printed circuit board pulled from a Sony or Shibaden Color Camera with a variety of video sync signals supplied to it from a sync processor deriving Color Burst, Subcarrier, Sync and Blanking. A large multi-turn Hue knob is

present to rotate the overall hue of the colored picture. The knob adjusts the phase of the chroma subcarrier feeding the NTSC encoder while keeping the Burst phase constant.

A common matrix configuration is to cross-wire the order of the inputs to other colors. This causes overlapping colors to add together forming new colors. An example is to tie: Input 1 to RED, Input 2 to Green, Input 3 to Blue, Input 4 to RED and GREEN (yellow), Input 5 to RED and Blue (magenta), Input 6 to Green and Blue (cyan), and Input 7 to Red, Green and Blue for a monochrome mix. The input gain controls overdrive the non-linear amps and the multiple cameras create additive color mixes of their input signals. Some of the input cameras could be pointed in a video feedback loop. Other cameras would point at a "magnetically scan processed" monitor modulated by audio signals. The magnetic scan processing is achieved through extra deflection yokes placed on top of an existing black and white monitor yoke. The extra yoke is supplemented with additional coils wound around the neck of the picture tube, all driven by high power audio amplifiers. The deformed magnetic image is re-scanned off the face of the tube and fed into the colorizer. This forms color spaces that can be superimposed upon other synthetic image sources. The combination of signals by an external video keyer joins the colorized collage with other video backdrops, forming a rich video landscape.

—J.S.

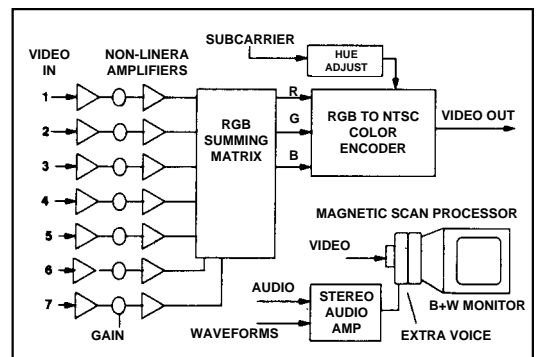

# GEORGE BROWN

**Video Sequencer**, (a.k.a. Field Flip/Flop Switcher, with digital control), 1972  
**Multkeyer** (Analog with digital control), 1973

GEORGE MUST HAVE DEEPLY understood numbers. When Steina wondered about New York running out of phone numbers, given the fact, that numbers with 0 or 1 as a second digit were reserved for long distance, he calculated the total number available in his head. We looked at him in disbelief—“oh that’s easy, it’s just a formula.”

I think he was a Vietnam veteran. He did not talk about it but he just did not talk much about anything. He thought he was of Hungarian extraction and the story that still stays with me is when he once “borrowed” a gasoline truck and drove it from New Jersey to New Hampshire. It was found parked in front of his girlfriend’s house and that’s how he learned some electronics: in jail.

The Video sequencer was inspired by binocular experiments and by our friendship with Alfons Schilling. We played a lot with the “Pulfrich Effect” using video. We even had a show on it in The Kitchen. We wanted an instrument to encode left/right eye into a sequence of video frames recordable to tape for later decoding. We never got further than that in our stereo-video experiments, but I still use it as an electronic shutter when photographing the screen.

George’s instruments put us right into the middle of media experimentation. To us they felt very sophisticated and, just as with digital tools and the computer, we never reached the bottom of the trunk. To me a good tool generates its own secrets at a much greater rate than it discloses them. —W.V.

## VIDEO SEQUENCER

The George Brown Field/Frame Video Sequencer is a programmable digitally controlled switch between two video sources in a field or frame rate. Intended originally for the binocular investigation by the Vasulkas, this “clean switching” is performed in the vertical blanking interval, and its duration, order and length are set through a front panel knob and a collection of toggle switches. The switching timebase can be counted down from video vertical pulses, or triggered externally from audio or other sources.

A pre-scaler counter times the stepping speed of the sequence from an external sync source, or a front panel manual pushbutton switch. The counter speed from 1-63 counts is loaded into a register from the front panel knob. The output of the pre-scaler drives a 15 step sequence counter. The output of the sequence counter drives a set of 15 vertically oriented lamps indicating the step position in the sequence. Adjacent to the lamps are a set of 15

switches, their position selecting either the “A” or “B” video source. The sequence length can be reduced to less than 15 steps if desired, by a length register loaded with the control knob. Fast switching of frame rate sequences are easily programmed by flicking the toggle switches and viewing the output.

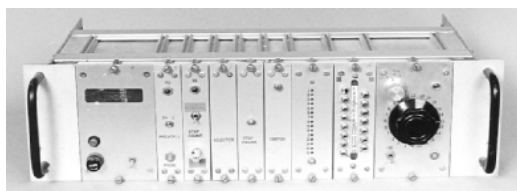

Field Flip/Flop Switcher, 1972. Collection of the Vasulkas.

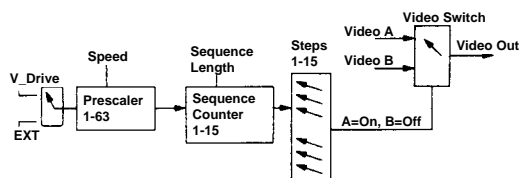

**MULTI-LEVEL KEYER**

The George Brown Multi-level keyer is an elegant instance of a digital sequencer controlling an analog video keyer. It consists of a programmable digital sequencer wired to an analog processing rack, where a digital "key priority encoder" combines with multiple analog keyer/mixers. An expansive matrix of red Light Emitting Diodes (LEDs), seven segment displays and a keypad, are used to interface with the digital sequencer. The analog keyer/mixer gates and prioritizes the six video sources, sorts them into multiple image planes, and routes them to a single output connector. This multi-level keyer was built for the Vasulkas in the early 1970's. Construction of the digital sequencer is on a large "perf-board" with TTL logic, wired by hand point-to-point, then painted black to hold down the connections. A computer interface was appended in 1977 to allow remote storing, loading and control of the program sequences.

The sequencer is a 16 step state machine with each state controlling: the video source, the mixer/keyer's priorities, a step duration, and a "next state." The timebase to advance the sequencer is handled by a pre-scaling counter set to either fields, frames, tenths of seconds, or seconds.

Programming the sequence is through a front panel telephone keypad, switches, an LED cursor, and two seven segment displays. A cursor points to each parameter of a sequence step: the video priority, the key priority, the step duration, and the "next step" of the sequence. The parameters are stored in a 16 step by 40 bit digital memory and are updated though pressing a "write" push-button. The front panel displays information about the current step of the sequence and advances as the sequence progresses. Once programmed, the sequence is stepped

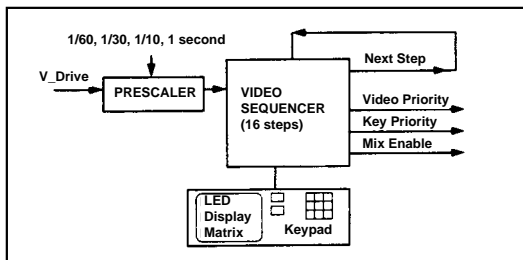

INFO frame 36451 to 39697

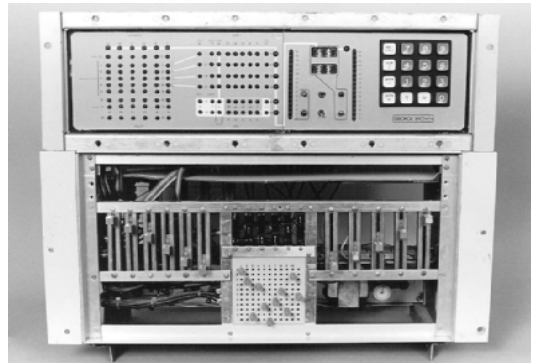

Multikeyer, 1973. Collection of the Vasulkas.

by a clock timed to external vertical drive pulses to count the elapsed fields. The analog video mix levels, key levels and output black levels are set by linear slider pots on the video processing rack.

A unique aspect of the keyer is its ability to set the priority or layering of the image. Given four camera sources, any one of the luminance components can be routed to position an image "in front." The priority encoding sets up "image planes" ordered from back to front. When self-keying with multiple cameras, the brightness of the image determines where to insert the keyed picture in front or back of the 5 image planes. A sixth input acts as a background and is always the furthest in back of the "image stack." This stacking and sequencing of image priority and its keying makes for an image layering not easily attained in conventional video mixers and without resorting to multi-generation tape loops. —J.S.

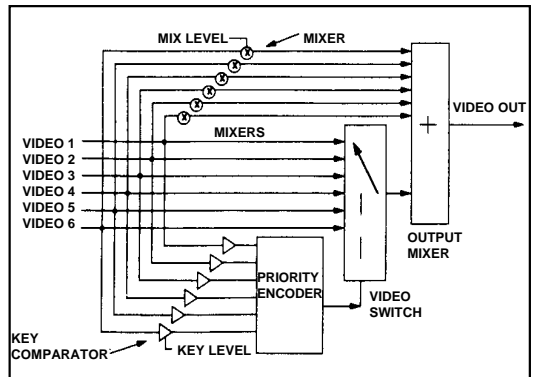

INFO frame 26586 to 29308

# DAN SANDIN

IP (Analog Image Processor), 1972

IT TOOK DAN Sandin to sober up those Vasulkas in their multikeyer euphoria. "You can not refer to image planes as in front of or behind, etc., that is just an illusory human perception. The Cathode Ray Tube knows nothing of this, I can prove it to you". Shortly thereafter we got a tape in the mail illustrating that what appeared as a circle in front of a square with a triangle behind the square, simultaneously showed the triangle in front of the circle.

Dan is dyslexic, for him video was the liberation from the hegemony of the written text. His focus in artmaking is holograms and stereo - yet he is blind in one eye. His message was that the Vasulkas love affair with a multykeyer had better stop. It makes them obviously blind to the ethic of the medium and the streak of illusionist self-deception could become a cancer on the body of video. They are bringing back old problems of hierarchical Renaissance space, obscuring the area of true investigation, limiting the freedom of the medium so far untouched by a dogmatic doctrine and individualist claims. It is an outright lie to suggest that things on the CRT can possibly happen on different planes. Anyway it will take the next tool, the computer, to deal with that!

We did not develop any further dialog or other confrontations. The "Chicago School" was full of bright people and was the longest surviving. They went through long and effortless metamorphoses in the curriculum of the tools, styles and purpose. There was also this strange role reversals with the women as users and the men as providers.

But I do not know enough about them to fully understand their inner dynamics. They always appeared self-satisfied, confident and full of rare knowledge. Their form of technological commune was the most refined, full of techno-sexual rituals, electro-erotic practises and secrets, which despite their obsession with the open dissemination of knowledge, have never been made public. — W.V.

DANIEL Sandin was born in 1942 in Rockford, Illinois. He received a BS in Physics in 1964 from Shimer College, Mount Carroll, Illinois and a MS in Physics in 1967 from the University of Wisconsin. In 1971 to 1974 he designed and built the Image Processor, an analog computer for video image processing. From 1972 to 1973 he developed a series of courses related to the expressive use of computers, video, and other new technologies. In 1974 he created special effects for a feature film: *U.F.O. — Target Earth*. He lives in Chicago, Illinois.

"DURING THE CAMBODIAN crisis in 1969, the school was shut now. The arts faculty, because they trusted their students and worked with them, kept the art department open against the general trend. We were kind of a media center for a lot of movement stuff. We did posters, graphic art, utilitarian stuff for the great movement. One of the problems was that there were all these instantaneous courses and it was a real problem letting people know where they were. Someone suggested the idea of setting up a string of video monitors with a camera and a roller kind of thing to announce these meetings and have them run continuously. We set this up and in the process, borrowed some cheap Sony equipment: a single camera with a RF modulator strung to 6 RF monitors up the column where the elevator was which went to all the lounges. I became fascinated with the image. When the meet-



FRAME 166 step through next 11 frames



STEP FORWARD



STEP BACK

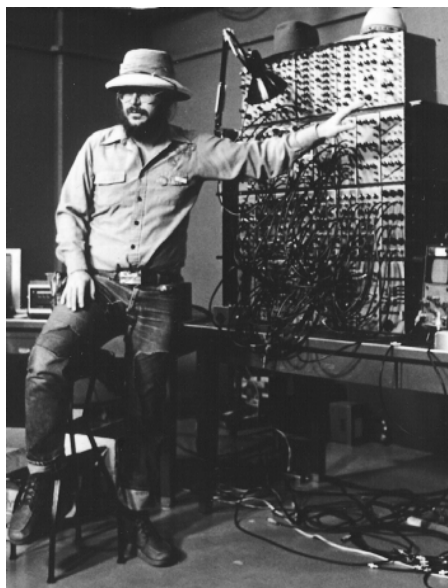

Left: Dan Sandin with the IP (Image Processor, 1972, Chicago).  
Below: Dan Sandin's IP in studio with other instruments.

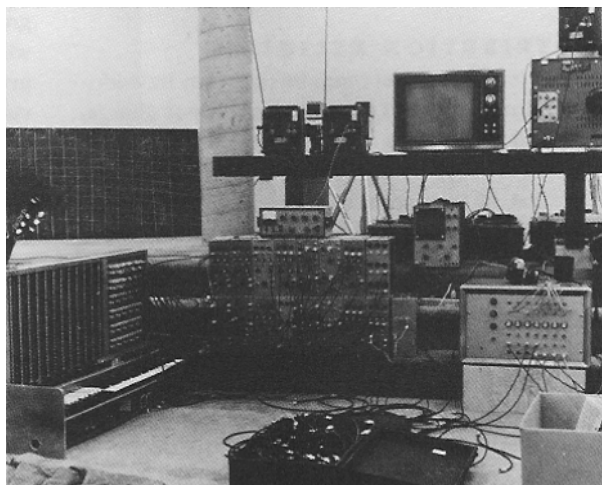

ing was really crowded we put a camera and a mike in there to cablecast. I just became fascinated with the image on the screen, and I would sit by the screen and stroke it.

So we asked the question of what it would mean to do the visual equivalent of a Moog synthesizer. I didn't know it was going to be more trouble than that. I just went through all the Moog modules and said if you center their bandwidth to handle video and you do the right things with sync, what would they do? The step from that to the analog IP was a very small one in concept. So I had the idea long before I knew any technology to implement it. I got the Moog synthesizer plans and looked at them, understood how the circuits worked.

I thought I was going to knock out the IP in a couple of months so that fall I started to teach myself electronic design.

I'd been a radio amateur when I'd been a kid but I certainly didn't know how to design circuits. I could certainly copy things out of *Popular Electronics*. I was comfortable with it but I didn't know enough. So during that nine months I taught myself electronic design by getting photo boards and building circuits. It took me about a full year to build it before it was running even in black and white.

I met Steven Beck who had been at the University of Illinois and had done this thing which was based on oscillators and relays and stuff and Salvatore Martirano had this early version of the Sal-Mar Construction and was performing on it. Then that's when I met Phil Morton who was at the Art Institute and I saw him showing some tapes over in the corner.

Well, when it got its own color encoder it became a much different instrument. Paik/Abe is a beauti-

ful colorizer but it's traditional. You can't say, I'm going to get up this kind of key situation and put red here, for instance. You can't drive it, you can only ride it. The amplitude classifier and refinements came after that.

I had always the idea of giving it away and letting people copy it. Long before any building started, that was my own philosophy: to give it away and take this business about being paid by the state to develop and disseminate information very seriously.

—D.S.

### DISTRIBUTION RELIGION

The Image Processor may be copied by individuals and not-for-profit institutions without charge, for-profit institutions will have to negotiate for permission to copy. I view my responsibility to the evolution of new consciousness higher than my responsibility to make profit; I think culture has to learn to use high-tek machines for personal aesthetic, religious, intuitive, comprehensive, exploratory growth. The development of machines like the Image Processor is part of this evolution. I am paid by the state, at least in part, to do and disseminate this information; so I do.

As I am sure you (who are you) understand, a work like developing and expanding the image Processor requires much money and time. The "U" does not have much money for evolutionary work and getting of grants is almost as much work as holding down a job. Therefore, I have the feeling that if considerable monies were to be made with a copy of the Image Processor, I would like some of it.

So, I am asking (not telling) that if considerable money were made by an individual with a copy of the Image Processor, or if a copy of the Image Processor were sold (to an individual or not-for-profit institution), I would like a 20% gross profit . . . ! Things like \$100.00 honorariums should be ignored.

Of course enforcing such a request is too difficult to be bothered with. But let it be known that I consider it to be morally binding.

Much Love.

Daniel J. Sandin

### IMAGE PROCESSOR (IP)

The Dan Sandin Image Processor or "IP" is an analog video processor with video signals sent through processing modules that route to an output color encoder.

The IP's most unique attribute is its non-commercial philosophy, emphasizing a public access to processing methods and the machines that assist in generating the images. The IP was Sandin's electronic expression for a culture that would "learn to use High-Tech machines for personal, aesthetic, religious, intuitive, comprehensive, and exploratory growth." This educational goal was supplemented with a "distribution religion" that enabled video artists, and not-for-profit groups, to "roll-your-own" video synthesizer for only the cost of parts and the sweat and labor it took to build it. It was the "Heathkit" of video art tools, with a full building plan spelled out, including electronic schematics and mechanical assembly information. Tips on soldering, procuring electronic parts and Printed Circuit boards, were also included in the documentation, increasing the chances of successfully building a working version of the video synthesizer.

The processing modules are mechanically housed in a set of rectangular aluminum boxes with holes drilled for BNC connectors and knobs. The modules are stacked into an array or "wall-of-modules." The signal routing between modules is patched with BNC coax cables plugged into the front panel of each module. Each box front panel has a unique layout of connectors and knobs, prompting many users to omit the labeling of connectors and knobs, relying solely on the "knowledge" of the machine gleaned from its construction. The number of processing modules was optional, but the "Classic IP" is formed with a "wall of modules", often stacked 3 high by 8 wide, filling a table top.

An NTSC Color sync generator, analog processing modules and an NTSC Color encoder built around a Sony color camera encoder board, forms the "IP." The analog modules are:

- 1) A Camera Processor/Sync Stripper which takes a black and white video signal, DC restores it and outputs an amplified version without sync.
- 2) Adder / Multiplier which allows the combination, inversion mixing and keying of multiple image sources. The adder section can superimpose or invert the image polarity of multiple sets of incoming



signals. The multiplier takes the two summed video sources and forms a linear mix between them. The mix or "key" control signal is externally supplied. A fast changing control acts as a gate or "key control." A slower changing control input causes a soft mixing of the video inputs. A static control signal turns the multiplier into a "fader" unit, fading between the two sets of inputs.

3) Comparator - two inputs A and B are sent to a *high gain video amplifier*. This "discrete digital" output is developed if A is greater than B and runs at video speeds. With the *comparator* output sent to the control gate of the Adder/Multiplier, a hard-edge keyer is formed.

4) Amplitude Classifier - A string of comparators is assembled to compare an input video signal against a ladder of brightness levels. The output of the classifier is 8 discrete "digital" channels, forming a set of intensity bands, corresponding to 8 contiguous grey levels evenly spaced from black to white.

5) Differentiator - this module generates an output signal based on the rate of change of the input signal. Six inputs with progressively larger time constants, respond to the edge rates of the input source. The shorter time constants respond to sharp horizontal edges, the larger time constants respond to softer edges.

6) Function Generator - a non-linear amplifier with an effect "more complex and controllable than photographic solarization." Adjustments for negative, positive and near zero signals are possible through knob controls on the front panel

7) Reference Module - a collection of 9 potentiometers with nine corresponding output jacks. The potentiometers dialed control voltages needed to

drive other analog processing modules.

8) Oscillator - a voltage controlled oscillator with sine, square and triangle outputs made available. The oscillator can be externally triggered to lock the oscillator phase to horizontal or vertical sync.

9) Color Encoder - an RGB to NTSC encoder, used as the final output stage, and constructed from a Sony DXC500B color camera encoder PC board. Two outputs are present: a monochrome output from the summed Red, Green and Blue inputs, and a color NTSC video signal formed from the RGB inputs. Wiring from the Amplitude Classifier through the adder/mixers to the color encoder results in a "threshold based colorizer." When driven from multiple Adder/Multipliers, a combination of monochrome and color images can be formed from oscillator waveforms and camera based sources.

10) NTSC Color Sync Generator - a stand alone NTSC color sync generator develops all needed synchronizing or sync signals to run the IP. Composite sync, slanking, surst-slag and subcarrier form the set of timings needed by the Color Encoder module. Horizontal and Vertical Drive signals are also generated to drive the timing of external black and white camera sources.

11) Power Supply - supplied all necessary power voltages to run the processing modules. +12, -12, +5, -5, and +14 were developed and run out on a "power bus" connecting the modules together.

Partly due to it's low cost and the free dissemination of information, the Image Processor's educational success can be found in its numbers. More IP's were built in its time than any other commercial "video-art" synthesizer. —J.S.

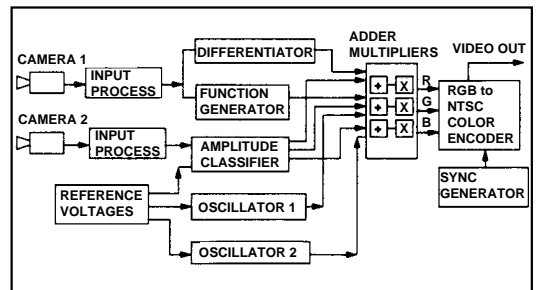

# BILL ETRA & STEVE RUTT

Rutt/Etra Scan Processor (Analog), 1973

I ALWAYS WONDERED how it must have felt to be one of Bill's cats. They had grown to enormous proportions taking over the house, making any guest a pitiful addition to their kingdom.

I fantasized that the cats, having no other reference to the proportions of the world had looked up to Bill to settle their sizes. They were many and they were big, real big.

The instrument called Rutt/Etra, named after their inventors, was a very influential one. Etra, with his art affiliations, had placed the instrument much closer to the hands of individual artists for the right price. Almost everybody I respect in video has used it at least once. Its power was in the transformation of the traditional film frame into an object with lost boundaries, to float in an undefined space of lost identity: No longer the window to "the" reality, no longer the truth.

I CANNOT TELL YOU MUCH about Steve. We met almost always in a formal situation. But his factory was a special case, something we all wanted to have exist, something where the artist would participate directly in tool-making and which would facilitate the cultural continuity of invention we know and treasure in photography, film, and video.

But we knew his crew pretty well. Sid Washer in particular. We met him well before he worked for Rutt. He invented a TV set modulated by a guitar, very live and interactive. Like many others, he had insisted that Paik caught a glimpse of it and the cat was out of the bag. —W.V.

"I WAS AT THE TV LAB for a while, so I built a Nam June-type machine. The one Barbara Buckner used. It was from looking at the picture and from looking at the TV Lab's machine. I built it with the 11" trinitron which was a slightly better monitor, and a bigger yoke and different amplifiers, but there was no schematic.

Steve knew electronics. He had not finished college but had been brought up with electronics. I said I wanted help doing this and Steve said he wanted money and eventually I convinced NET to give him the right amount: \$3,500, which is what they paid for the first Rutt/Etra. Steve and I added about \$10,000 of our own money which we borrowed from our families and built the first machine. It cost us \$13,000 and they got it for \$3,500.

It would probably not have happened had access been available to a Dolphin computer. I'd seen Ed Emshwiller's stuff, the one before Scapemates. The people twisting in space.

I knew almost nothing when I started. I knew you had to sum the waveforms. That was obvious from the oscillators. I knew you had to attenuate them,

which is multiplication. Steve knew about diodes, resistance networks, etc.

The first machine we built was really deflection on a regular oscilloscope, in fact I have the oscilloscope downstairs. We used huge pots, to actually change the deflection voltages on the yoke, to zoom and rotate. I thought it was going to cost under \$5,000 and be sold to artists and schools. I still don't like the broadcast companies particularly.

It got too expensive, among other things. The price went up because we tried to sell it to broadcast engineers who couldn't use it anyway. They didn't have the initiative to use that sort of complex equipment.

We got to be pioneers which is great and glorious, if it continues. Of course, if it ends that's something different. If video had only a small part in it, then we all get washed out. But for a while we got to be pioneers." —Bill Etra



FRAME 213

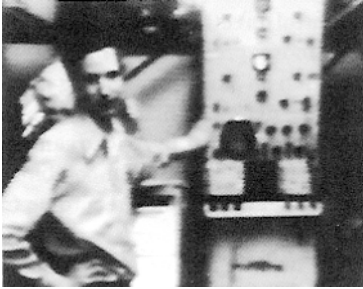

Above: Bill Etra and Steina Vasulka at The Kitchen, 1972.  
 Left: Steve Rutt.  
 Below: Rutt/Etra Model RE-4 Scan Processor.

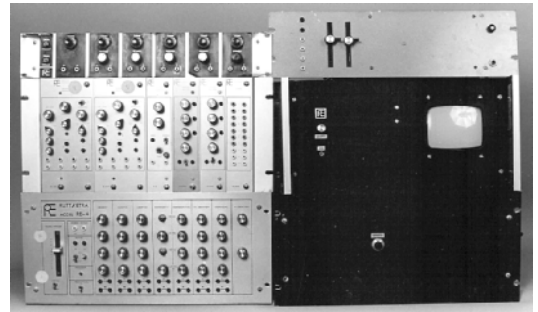

**“WHAT WE DID** over the years was raise the price and improve the quality. We mostly raised the price but we never made money on it. It’s the old story: if you’re building it for five dollars and selling it for four, you can make it up in volume. So we decided we had to raise our prices. We doubled the price and nobody could afford it any more. We pushed the price way up and that was the end of the creative market for the thing.

One of the things that hasn’t changed is the modules, which has become sort of a joke for one thing because this waveform generator never worked right. I shouldn’t say it never worked right, it never did all the things we knew it could do. In the early modules it was sort of OK because it was this early state and nothing worked right back in those days. We used to have a standard procedure that if something didn’t work right, that was the way it was supposed to be. But we never changed the modules at all. The only thing we ever did was put power supplies on the modules so that you could line them up and plug them into the machine. We then found out that the power supplies were the weakest link

and they used to blow out all the time.

We did two things differently than the Nam June machine. One thing was that the Nam June machine was built out of surplus parts, whatever happened to be available he snuck in. We started from scratch and built it so it was a little more refined and all plugged together. The other thing is we DC coupled everything which had been AC coupled. That was the main thing. Without that you couldn't get positional movement, you could only get waveform distortion. You couldn't actually take something and slowly flip it upside down.

Most of the modules we used were things that had been analog computer concepts such as multipliers, summing amplifiers, dividers, log functions. I was just sort of listening to what people wanted and building it and Bill was one of the people that I was listening to a lot. In the early stages somebody wanted this and somebody wanted that and we built modules. The books that we built from were mostly the Motorola book and a little bit of the National book. I had this big Motorola book from which we discovered the multipliers that we used. You'd look up an op amp and it would have eighteen different circuits on how to use it, none of which worked, of course. Half the stuff in the book was always screwed up. You'd built it and then de-bug it.

I'm certainly not an artist, under any stretch of the imagination. I create with the thing because I know how it works electronically and I'm able to create stuff that I've passed off as art. Some of it for considerable amounts of money considering what it was. But I wouldn't call myself a creative artist. And a lot of the stuff that has been created with this, that people call art, I'd also put into the same category as the stuff I do as a technician. I don't think somebody walking over to his TV set and turning the horizontal hold off and photographing the screen constitutes art but neither does a pile of cement blocks at the Metropolitan Museum of Art constitute art. I have a pile of cement blocks in the back which I'm considering also selling for \$10,000 but nobody wants to buy them yet. I also have a pile of plasterboard which I'm going to put out as soon as the cement blocks are sold. By the modern standard I'm an artist. By other standards I'm sure I'm not, including my own." —Steve Rutt

## RUTT/ETRA SCAN PROCESSOR

The Rutt/Etra Scan Processor is a real-time system which electronically alters the deflection signals that generate the television raster.

Developed in the early 1970's in New York by Steve Rutt and Bill Etra, this analog scan processor loosely resembled the Scanimate, but was simplified in operation and offered at a lower cost. Steve Rutt manufactured the unit, while Bill Etra refined the scan processor concept, placing an emphasis on external voltage control of the processing modules. Its principle of operation is to intercept the sweep signals of a black and white video monitor and modulate these signals with analog control voltages. The voltage control directly modifies the sweep waveforms and is more predictable than other magnetic versions such as gluing or winding additional yokes onto the necks of black and white monitors. Images are 're-scanned' by a video camera facing the modulated display monitor for combination with other video signals and final recording to video tape.

The Rutt/Etra is housed in three rack mount cabinets. One unit holds a small black and white display monitor with high power deflection yokes and a video amp. Another box contains the analog sweep processing chain, and a third box houses the control voltage generators with various oscillator/function generators, a sequenced ramp generator, and a summing amp to combine the signals before routing to the sweep processing box.

The raster is manipulated by control voltages feeding two processing chains, one on the horizontal axis (H), and one for the vertical (V). Each chain contains four-quadrant multipliers and summing



INFO frame 39698 to 40245



FRAME 210 step through next 2 frames



STEP FORWARD



STEP BACK

amplifiers placed between the H and V ramp generators, and their corresponding deflection yokes. A cross coupling "rotation slot" is available to insert an analog "2 by 2" rotation matrix but remains empty in most units. Dual multipliers driven by a common control voltage adjust the "zoom" of both the sweep axes. The video signal runs through a two quadrant multiplier followed by a summing amp for intensity and brightness control. Each sweep chain has a two channel switch in front of its processing module control inputs, splitting the raster into two independently adjustable rasters. Multiple 15 turn knobs are present on the front panel of the modules to adjust size, position, zoom and intensity. Due to cost, the knob's position is unmarked. This position is discovered through twirling of the knob fully to one side then back to find it's current control setting.

The control voltages are driven either from static voltage sources or from function generators locked to: sync signals or themselves (freerunning). AM and FM control allow cascading these control signals.

The need for intensity compensation, to correct for brightness changes due to the speed of the beam, is problematic in small rasters that can "burn" phosphor holes in the display tube. Resolution loss due to the rescan process, and difficulty in attaining repeatable raster movement using analog control generators, are some of the shortcomings of the analog scan processor.

The raster's size, position and intensity can each be modulated through voltage control signals. These control signals fulfill a commercial function: to generate swooping titles and sliding graphics. A more esoteric use is demonstrated in the "Vasulka Effect" the input video brightness connects to the vertical position control. This causes the brighter parts of the video to "pull" the raster lines upward. When combined with other synthetic waveforms,

the raster forms a three dimensional contour map where video brightness determines elevation. The generation of video objects built from the underlying raster structure is evident in video tapes created by the Vasulkas.

Scan processing starts out as an orderly progression of swept image lines. The electronic control of the size, position and brightness, contorts the electronic envelope of the picture. This modulation of the scanning beam forms moving surfaces, objects and shapes built upon the underlying scanned raster structure. —J.S.

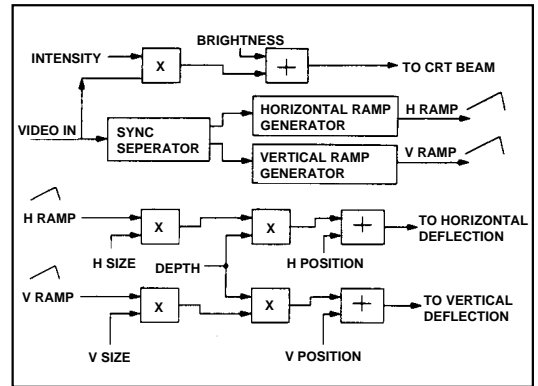

# DAVID JONES

## Jones Frame Buffer (Spatial and Intensity Digitizer), 1977

WHEN WE MADE OUR FIRST unofficial grand tour through Europe as the self-acclaimed ambassadors of video, we were picked up by a very young looking, lean man at the Luxembourg airport. We got into his rental car and headed off to Paris. The man had obviously not slept much and was not in the mood for conversation. Somewhere after Verdun he started to speak.

We learned a lot about Jack Moore, about the time in Amsterdam, the Melkweg and Mr. Mori at “Sony of France”. Dave Jones had just left for the States and it would be a couple of years before we meet him.

On the other hand, that same night in Paris we met Depuoy and his colorizer. I cannot recall the functions now, but I still remember the front panel. The device is now with Don Foresta in Paris and needs some reconstruction. I am afraid, it will fall between the cracks for this show.

Jones has become the favorite designer for the up-state New York people but it took this show for us to get closer to him.

By the way, our Paris driver was Kit Galloway. We have had many encounters with him since, latest this fall through the Electronic Cafe. Steina played her violin, remote-controlling a lasedisk performance over the telephone from Santa Fe to Los Angeles. —W.V.

DAVE JONES IS A Canadian-born video artist and engineer who has been producing video tapes and performances for over 21 years and developing image-making tools for over 19 years. He has worked with electronics since he was ten. At age 12 he built a shorwave radio from a kit, then in highschool he built an AM radio station. After high school he helped to run a mixed-media performance troupe in Europe, known as Video Heads. In the seventies he built, modified, and repaired video equipment for artists and organizations throughout New York State, and began in 1974 working with E.T.C. designing and building video tools for their studio. He was involved in video performances and installations at and E.T.C. and elsewhere. During the late seventies, continued designing analog imaging tools and began to work on the first of many digital imaging machines. He also helped develop the computer system at E.T.C. and wrote the software for it. The early 80s were spent working both in industry and the arts, including the designing of hardware and writing of software for the Amiga computer. Image processing tools designed by Dave Jones are in use in artist’s studios around the world as well as in schools. Jones has become known for innovative and powerful video tools that let artists explore the signal.

### FRAME BUFFER

Dave Jones explored early digital video processing techniques through design work at the Experimental Television Center (ETC) in Binghamton N.Y. In April 1977 he created the 64 by 64 frame buffer, which stores images as a pattern of 64 horizontal by 64 vertical squares, with a choice of 16 grey levels per square. The cost of memory and analog to digital conversion limited the number of grey levels and resolution. These limitations yielded a video image meshed into a charming box-like grid of intensity, that is frozen or held under front panel control.

A 4 bit, 16 level video-speed Analog to Digital Converter, samples the monochrome video input. This is fed to a 4K by 4 bit static Random Access Memory (RAM), where it is held on command by a front panel push button, locked to the vertical interval. The output of the frame buffer memory

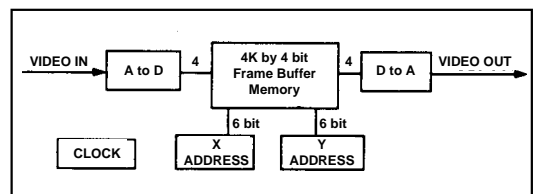



FRAME 143 step through next 9 frames



STEP FORWARD



STEP BACK



INFO frame 33636 to 36450

Left: Kit Galloway, Dave Jones, Jack Henry Moore, founders of VIDEOHEADS, at the Melkweg, Amsterdam, 1972.

Below: Dave Jones and friends. Bottom: Jones Frame Buffer, 1976. Collection of Gary Hill, Seattle Washington.

passes to the output Digital to Analog converter, changing the video signal back to its analog form. When running "live" the image bypasses the frame buffer memory, passing straight to output. When "frozen," the image is pulled from the frame buffer, showing the last stored picture. A horizontally/vertically locked address counter supplies the timing for the memory. A later addition allowed control of the write pulse by an external signal, developing a coarse keying between the stored and live image. The coarse "mosaic" and 16 level contouring of video intensity are components of image style seen in the 64 by 64 buffer. —J.S.

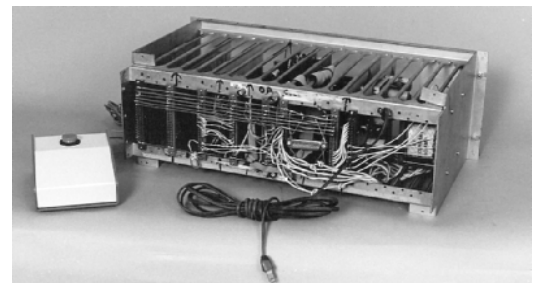

# DON McARTHUR

SAID (Spatial and Intensity Digitizer), 1976

I THINK ONE ALWAYS REMEMBERS the moment of change of an esthetic norm in one's mind, first the photographic and film recollections from the memories of others, then our own experiences with first seeing video and holography. Such a moment happened to us in, of all places, Binghamton N.Y: looking at a digital image broken down into the numbers and reassembled again in real-time. That's how we met Don McArthur and his real-time digital buffer. In our greed for new images, without even discussing it, he was hired. A year later, he designed the basic skeleton of our first true digital image generator. We agreed with Ralph Hocking on the purchase of his flesh, under condition that the project would have a binary benefit for both places, ours in Buffalo and at ETC. The project would mirror all hardware and software development and Walter Wright would write the first program.

It only got half way through. Eventually we pulled it through without ETC by enlisting another character in this drama, Jeffy Schier. —W.V.

1938 WAS THE YEAR Donald E. McArthur was born in Holdrege, Nebraska. He received a Ph.D. in Theoretical Physics from the University of Nebraska in 1967. After teaching physics at SUNY in the mid-seventies, he began designing digital imaging systems for video. His creations include the Spatial and Intensity Digitizer for the Experimental Television Center in Binghamton, New York; and the McArthur/Schier Digital Image Generator developed with Jeff Schier for the Vasulkas. McArthur's interests include heuristic programming, digital electronics, video systems, and electronic music.

"AS SCIENCE ADVANCES, with the resulting advances in technology, we have new tools and new capabilities which influence our world in many ways. This new technology not only influences the traditional art forms but also produces new forms of art. The development of high speed electronic components and circuits, the cathode ray tube, the video camera, and inexpensive video tape recorders enabled the development of video art. Advances in integrated circuit design and fabrication techniques have led to the development of small but powerful computer systems which can be utilized by the video artist to achieve a new dimension of control over the video image. With a computer-based video synthesizer (CBVS), one can generate a sequence of images while controlling each individual image with detail and precision that is many orders of magni-

tude greater than is possible with manual control.

The ability to control the dynamics of the image is especially useful to the artist if the system is capable of generating the image in real time. With this requirement in mind, the natural choice of devices for converting electrical signals to visual images is the conventional video system. This choice also gives the capability of recording the video compositions with a conventional video tape recorder and of broadcasting to a large audience through existing network systems.

There are basically two modes of operation of the system: interactive-compositional mode and automatic-production mode. In the compositional mode, the artist can enter programs and parameters through the keyboard, observe the resulting sequence of images, and then modify parameters through either the keyboard or a real time input and thus build up a data set for a complete piece. The data set, representing all the aesthetic decisions made by the artist, is stored in the computer at each stage of the composition. When the composition is finished the system will operate in the automatic-production mode generating the final video signal in real time with no intervention by the artist. The artist may also choose to use a combination of these two modes in an interactive performance or to allow an audience to interact with the system operating automatically. The system is structured so that all of these variations can be accommodated by appropriate programming.



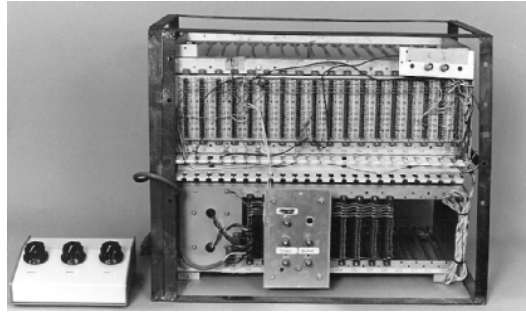

Above: SAID, 1976.  
Left: Don McArthur.

The system may be operated as a generating synthesizer which produces a video signal entirely from internal signals or as a processing synthesizer which utilizes video signals of external origin such as a camera. Either of these two types of operations is carried out by a configuration of elements modules, each of which performs a class of functions, with the specific function during one frame being determined by the control parameters received from the computer.

*From: "A Computer Based Video Synthesis System"  
—Donald E. MacArthur, June 1977*

**THE SPATIAL AND INTENSITY DIGITIZER,**

or "SAID", arose from an early attempt to create a low cost video-speed Analog to Digital converter (A/D). In 1976 no monolithic silicon A/D converters existed, and the cost of equivalent industrial modules was outside the range of most video art budgets. As this component was basic to digital video processing, a 6 bit A/D converter was attempted. An A/D converter of 4 bits or less was commonly constructed using strings of high speed comparators, but resolutions greater than 4 bits was difficult to perfect.

A video A/D converter is built from three main components. A sample and hold input amplifier, an analog to digital conversion circuit, followed by a binary encoding stage to generate a unique binary number for each of the analog to digital thresholds. The sample and hold amplifier picks out a sample of the video voltage, and holds its value until it is fully

converted into digital form. The conversion from an analog voltage to a digital value is followed by the binary encoder that develops a digital output as a stream of 6 bit binary numbers, representing 64 video grey values.

The total conversion time of all elements determines the highest clock speed possible. The conversion time was slower than desired, so a horizontally locked oscillator was used to slow down the clock rate until the conversion was stable. This was generalized to allow wide variation of oscillator speed to horizontally sample the image. The output of the A/D converter is fed to a companion Digital to Analog converter of 6 bit resolution, completing the conversion process from analog to digital then back to analog.

The purpose of this circuit is to digitize the video signal into numerous digital thresholds and then sample them along the horizontal time axis to create vertical strips. The spacing or width of the vertical strips of video is adjustable through an oscillator knob. A switch to turn off selected digital bits is also available. This is an early example of the "posterize" function (bit selection), while the stripes are the horizontal component of a "mosaic" function, both found in digital video effect devices. —J.S.

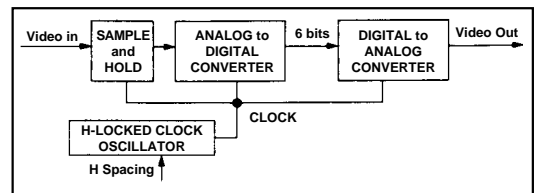

# DON McARTHUR & JEFF SCHIER

## Digital Image Processor, 1976

THERE ARE AT LEAST TWO OF THEM in one body, Jeffy and Jeff. Jeffy of course is playful, funny and fast. Jeff is a reincarnated police interrogator. They both live with a third person, Diane in a little wooden house erected right over a long forgotten geological fault in Oakland.

Without him, being our student in Buffalo, we could never have gotten our education. Luckily, the only way Jeffy, living in the left hemisphere could inform Jeff living in the other, was through the acoustic interface of speech. To close the circuit, an interlocutor had to be found, Steina or me. That's how we learned.

Jeffy vastly expanded the McArthur concept. He put several modules on the bus, elevating it from mathematics to a visual experience. But his true masterpiece, "The Image Articulator," was yet to come.

—W.V.

JEFFREY SCHIER was educated at the State University of N.Y. in Buffalo, where he worked as a design engineer for the Vasulkas. During that time he facilitated the software/hardware interface of several unique video processing machines to a DEC LSI-11 microcomputer: George Brown Multi-level Keyer, Seigel Colorizer, Rutt/Etra Scan processor. Schier was the co-designer of the MacArthur/Schier real-time Image Processor. Later he designed and implemented the Image Articulator: a bit-slice frame buffer with real time image manipulation abilities. Subsequently, he worked as project leader for color graphics CAD Workstation applied to PC board design; he was lead designer of the GMR2800 Computer Graphics Image Processing system at Grinell Systems, and he has worked as a senior research engineer at Cubicomp Corporation, and at Aurora Systems. From 1987-89 he worked for Pinnacle Systems as project manager for development of PriZm digital video effects system (DVE). The DVE performs real-time rotation, perspective transformations, and curved/warping of the image; with the aid of a color menu interface. Presently, he works at Chips and Technologies, Inc. as Staff Design Engineer.



FRAME 225

### DIGITAL IMAGE PROCESSOR

The Schier/McArthur Digital Image Processor was constructed in 1976-1977 at Steina and Woody Vasulka's loft in Buffalo, N.Y. It began as a mathematical exploration by Don McArthur of the digital raster and was built from digital modules locked to video time by a 16 bit micro-computer: a DEC LSI-11. It was built in stages starting with the sync generator and computer interface. A digital Selector, Arithmetic-Logic Unit, lookup/pattern RAM and a rectangular Window Generator were added later. The video outputs came from three 4 bit digital to analog converters, and was converted to color composite video by an external NTSC color encoder. The video tape recorder was on continuous standby, allowing documentation of the design process by Steina through "pressing the record button."

The modules were "wire-wrapped" and connected to the computer control and timing bus at the rear of the modules. The digital video paths were patched together with multi-conductor ribbon cables plugged into the front of each module. External audio could be patched in or out from the front panel, converting the video timing signals to sound. Emphasis was placed on internal square waveforms to form the first pictures made from the horizontal and vertical bar patterns that subdivide the raster. A borrowed time base corrector was "hot-wired" to pull out 6 bits of live digital video from its A to D (analog to digital) converter and color-mapped through the lookup/pattern RAM. A random "power-up" pattern was saved from the RAM and formed a favorite color test palette for adding colors to the image. The real-time

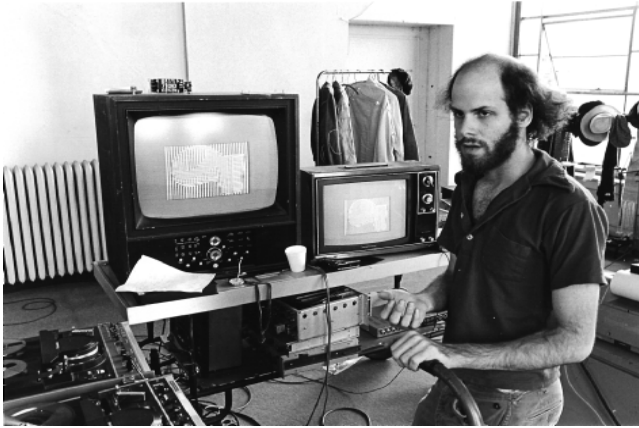

Left: Jeff Schier in the Vasulkas loft, 1977, Buffalo, New York. Photo: Woody Vasulka.  
Below: Digital Image Processor.

remapping of intensity to color formed a color precision (64 levels) unseen in analog colorizers. Dual four bit Analog to Digital converters were later constructed to digitally combine two image sources. Operations were performed at 4 bit resolution per red, green and blue channel, but were funneled down to 6 bits when running through the lookup/pattern RAM.

The digital combination of binary images formed unique geometric color patterns. These were unexpected and did not correspond to other analog processes. This became evident when the Arithmetic/Logic Units (ALU's) were installed. The ALU's performed arithmetic functions (addition, subtraction), and logical functions (And, Or, Exor, Negation) and wacky mixed arithmetic and logical operations that were "thrown in" by the semiconductor vendor, such as (A OR B plus 1). The bitwise combination of image combined with overflow/wrap-around conditions generated unusual patterns of color and box-like textures without equivalence in analog video. The binary operations made sense but the images were a digital surprise. "Official" test images were needed to test out the ALU process. This consisted of a white styrofoam sphere or cone and Woody's hand waved in front of the camera. These test images contain 16 discernible levels of grey, useful to disclose the arithmetic/logical binary combinations and overflow conditions. The explorations of real-time digital video at the Vasulkas predated later image processing and digital video effects units. The exploration of binary operations between images has largely been ignored



in image processing and computer graphics in it's quest for photo-realistic imagery.

Time-locked software marching to the video frame rate formed the real-time control structure needed to operate the digital image processor. Various test and control table programs were written in Fortran and PDP-11 Assembly language to operate the processing modules. Walter Wright programmed "BARBAR," an assembly language control program with independent timing control stacks. BarBar's timing stacks control processing module functions, time delays, and the looping of the control sequence. The inclusion of random functions exercise the hardware, contributing to long sequences of digital permutations.

The hardware consists of a rack of digital processing modules, a gen-locked sync generator, a vertical interval control bus, and a microcomputer to orchestrate the field by field control. The digital video paths for the processing modules are "patched"

through their front panels. Signal Path: Input is received through camera sources, video tape sources, or the internal pattern source (H and V timed bar patterns). The camera and VTR sources route through the A/D converters first. There they are front panel patched to the processing modules and converted back through the D/A converters into RGB video and then to a RGB to NTSC encoder for composite color output.

1) Microcomputer: a 16 bit DEC LSI-11 micro-processor coordinates control words for the processing modules and handles user interface functions.

2) A Vertical Interval Control Buffer and Transfer Bus: control information is loaded into this control buffer by the microprocessor during the current active field. The data is shipped down to processing modules during the next vertical blanking interval.

3) Processing Modules:

A) Analog to Digital Converters (A/D) consisting of two 4 bit converters.

B) Selectors (3 groups) which choose between 8 horizontal, and 8 vertical frame-locked patterns, and an external digital source. The selectors allow bit-wise selection of horizontal/vertical timing components and external video inputs.

C) Arithmetic Logic Units (ALU's) which combine two digital input streams into a single output through combinations of arithmetic and Boolean logic functions (Output = function (A\_in, B\_in). The Boolean functions of 'AND,' 'OR,' 'EXOR,' 'EXNOR,' Ones Complement are present. The arithmetic 'A PLUS B PLUS CARRY,' 'A MINUS B PLUS CARRY,' 2's Complement are also available. Certain combinations of arithmetic with logical operations are possible, with a 'Constant' available on the 'B' input, useful for bit-masking.

D) Lookup consisting of an RGB lookup table with common digital address input is present to perform intensity/pseudo-color transformations. The memory could be loaded then scanned out as a small raster.

E) Window generator: three Window generators form an adjustable frame for gating/routing the digital sources. The frames are independently programmable on a pixel/line basis. Wipe patterns and title boundaries are formed by the same principle.

F) Digital to Analog Converters: one apiece for Red, Green and Blue components at 4 bits per gun.

4) A Gen-Lockable Sync Generator which forms sync timing, and subdivides the active screen into 512 H by 486 V coordinates. Both video sync and H and V timing information is available on the control bus to be picked-off the modules' program. A Phase Locked Loop locks the clock timing to an external sync source.

5) RGB to NTSC Color Encoder comprises the funnel for output and converts the RGB signals from the D/A converters to an NTSC color composite video signal for display and recording onto video tape. —J.S.

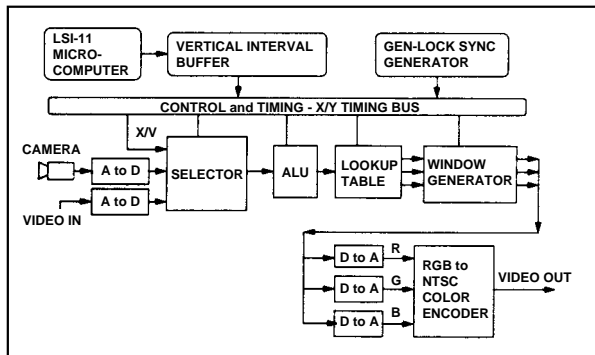

# AUDIO / VIDEO INSTRUMENT SPECIAL INSTALLATIONS

Following are three instruments included in the exhibition and identified as special installations due to characteristics that distinguish them from the custom built personal tools in the Audio/Video Instrument section: FEEDBACK was an ubiquitous phenomenon; the SONY PORTAPACK - both CV & AV - was an industrial introduction that put video in the hands and on the shoulders of anyone who could pay (including artists and activists); and, CLOUD MUSIC is an audio/video installation that was a collaboration by three artists in real-time that relies on inventive, sophisticated electronics.

—MaLin Wilson

*no date* **Experimental**

**VIDEO FEEDBACK WITH AUDIO INPUT  
MODULATION AND CVI DATA CAMERA**

1969 **Industrial**

**SONY CV PORTAPAK**

1974 - 1979

**Robert Watts,  
David Behrman  
& Bob Diamond**

**CLOUD MUSIC (Hybrid audio/video installation)**

Courtesy of The Robert Watts Archive, Sara Seagull and  
Larry Muller in collaboration with David Behrman,  
and Bob Diamond

# VIDEO FEEDBACK

## With Audio Input Modulation and CVI Data Camera\*

**SKIP SWEENEY** was born 1946 in Burlingame, California. BA in Theater Arts 1968 University of Santa Clara, California. Founded Electric Eye 1969 a group for video performances and experiments. Co-founded 1970 with Arthur Ginsberg Video Free America. Selected Group Exhibitions: 1971 Video Show Whitney Museum of American Art, New York. 1973 Video as Art Paris. Works: Philo T. Farnsworth Video Obelisk San Francisco. 1971 Video for Heathcote Williams's AC/DC Chelsea Theater Center, New York (with Arthur Ginsburg). 1972 Visual effects for Allen Ginsberg's Kaddish Chelsea Theater Center, New York (with Arthur Ginsberg). 1975 Video Art Institute of Contemporary Art, University of Pennsylvania, Philadelphia. Events and Performances 1971 University Art Museum, University of California, Berkeley. 1972 Video Free America Studio, San Francisco. 1973 The Kitchen, New York; Repertory Dance Theater, University of Utah, Salt Lake City. 1974 Avant-garde Festival New York. Lives in San Francisco.

**VIDEO FEEDBACK** is a dynamic flow of imagery created by the camera looking at its own monitor. It was often (and still is) the first phenomena that seduced users of video by its sheer beauty. Although everyone who discovered feedback was transfixed by it, feedback seemed an uncontrollable, roiling effluent byproduct of technology - one of those natural mysteries, appreciated but untamable. The acknowledged master of feedback was Skip Sweeney, organizer of the first video festivals and founder of Video Free America in San Francisco. To Sweeney feedback was "a religion - a wave to ride." Throughout his video work Sweeney has approached video as a real-time tool with an on-going involvement in video as live performance.

Included in this catalogue is a thorough scientific explanation "Space-Time Dynamics in Video Feedback" published in 1984 by Dr. James P. Crutchfield, Physics Department University of California, Berkeley. Sweeney, of course, was working with feedback in the late 1960's, and coaxed to life the complex images later technically described by Crutchfield.

*Following are excerpts from an interview(1978) of Skip Sweeney by Woody Vasulka about his early experiments.*

**Skip:** The first tools that I had were just a CV studio camera. I would leave a set-up in my basement back room. A camera shooting into a monitor, just the simplest camera and a monitor at an angle. And, the first tool was my finger on the contrast and brightness knobs - that drastically affected the response of the feedback . . . and, playing with the zoom, focus and tripod with its angle.

In my first explorations I set it up at almost 180 degrees, shooting at almost the same angle as the screen. Position became critical. Generally, I ended up wanting to be perfectly centered, finding the true axis in the tube. I was also playing with the termination switch. Using termination gave me increased gain. The next step - almost automatic - was trying to record some of this stuff, and I instantly discovered that a different affect was gotten by trading off contrast and video gain and super video gain with low iris and low contrast.

**Woody:** *So, would you go into a much more precise description of how you actually achieved control, because feedback is normally very hard to control.*

**Patience . . .** I also found something early that gave me a tremendous amount of control that other people don't get when they start playing with feedback - the use of a mirror. By placing a mirror that was angled, and by its angle creating a circle. In other words, if the angle was more than 30 percent the image was circular. For example, if I brought a hand between the camera and the screen, I would see hands from above and from below but, if I put a mirror up, the image was repeated and kaleidoscopic.

The mirror was generally angled below the camera, balanced on piles of something. How far up you moved the mirror, how far down you moved the camera - all those relationships completely changed the image. In fact I discovered you didn't need a mirror, a piece of glass at that angle had so much reflective capability. But, by using the mirror I instantly got feedback where the range was amplified . . . you had to practically knock the camera over



NANO C frame 18454 to 23665



Skip Sweeney, ca. 1983, with feedback set up at the Exploratorium, San Francisco, California. HW: Setchell-Carlson Television. Photo by Susan Schwartzberg.



to lose an image.

. . . There was a whole other discovery - the Setchell-Carlson camera with a detail knob. I ruined three cameras fiddling with them, not knowing how to get them back into a legitimate signal. My tape JONAS' FAVORITE was a combination of finding that you could get tremendous detail on the Setchell Carlson. Everyone else always had the contrast and brightness set high, and I got into turning them in low ranges and playing with the internal controls - the gain and the beams. I started getting the ability to control the speed of the images. One of the first corollaries I developed was the more you turned up the target voltage and the lower you turned the iris in combination, the slower the image got until you could really get it to crawl like slow motion. And then, by removal of the pedestal, by dropping the pedestal down, the blacks became completely black. Pushing the beams high I got the waterfall effect, where things would roll off as if they were rolling off the edge of a cliff. I could get feedback that was either pouring into itself, pouring out of itself or floating.

*I know you have been involved with Bill Hearn's VIDUIM.*

A the time my interest in the VIDUIM was its ability to generate an image. I didn't do the VIDUIM any justice at all because I didn't care for the kind of complicated images the VIDUIM could create. I cared only for the very simplest images. That's something I struggled with from the very beginning:

to try to achieve an image completely isolated from anything else. In other words, I wanted a simple black image where the white was keyed through and the image was simple kinds of circles that pulsed or waved to the sound of the music.

I guess the MOOG VIDUIM started to whet my appetite for keying and colorizing.

. . . I knew what I wanted to be able to do. I was very frustrated by not being able to turn something that was light, e.g. the white image of the MOOG VIDUIM to look dark. I couldn't do it because the George Brown Colorizer had no effect on the gray level. I think I developed an aesthetic of reversing what I was given, making brighter images dark and darker images bright, having the gray level be the heart of the colors I got.

*To what degree do you feel that you have influenced those particular elements.*

Those elements of Bill Hearn's colorizer? I feel like I'm the conceptual architect . . . because it is exactly what I asked for. I asked for gray level control, separatable key levels and gray level and chroma and hue. I wanted control over each separately. Alan Shulman deserves a certain amount of credit. Alan was always working with Hearn when that first colorizer was built.

\*Please refer to pages on the CVI DATA CAMERA in the Audio/Video Instruments section.

# SONY CV PORTAPACK

Industrial, 1969

THE INTRODUCTION of the portapack into artistic formulation was paramount. In the late 1960's the use of video was confined to close circuit installations, a very elegant solution to the use of video in the gallery. With the invasion of tape on the scene it took some time to settle the problem of exhibition. Speaking to Steina about reel to reel machines Bruce Nauman put it more directly: "I almost dropped video when tape was introduced; when the tape ran out there was no one in the gallery to rewind it, thread it and run it again."

It was an entirely different story for the socially engaged. The portapack was considered a revolutionary tool, almost a weapon against the establish-

ment. Overnight it dissolved the hegemony of documentary films. A vast number of genres sprang up (including the notorious 30 minute single take), and the documentary branch was never the same again.

The middle ground was also interesting. With tape new networks of distribution were quickly established. Video became truly international. It was easy to duplicate, mail, and view. With the introduction of the video cassettes in 1973 it became even easier, and harmonized with the exhibition purposes of video. By the mid-1970's video as art was fully entrenched in the galleries, with many developed genres, forms and concepts.

Only a few people tried to develop the so-called "abstract" genre. It failed in the first decade entirely. We and other people dealing with early synthetic images used tape primarily as extended studio material (input), and secondarily as a method of documentation of these new processes and phenomena unexpectedly popping up in front of our eyes. —Woody Vasulka







Steina and Woody Vasulka with portapack equipment, San Francisco, 1972. Photo:Warner Jepson.

# CLOUD MUSIC (Hybrid Audio/Video Installation), 1974-1979

Robert Watts, David Behrman & Bob Diamond

Courtesy of The Robert Watts Archive, Sara Seagull and Larry Muller in collaboration with David Behrman, and Bob Diamond

**BOB WATTS** Born 1923. Studied engineering and art history. Professor of Art, Rutgers University. Associated with Fluxus. Produced Yam Festival and Monday Night Letter with George Brecht. Died 1989, Bangor, Pennsylvania.

**BOB DIAMOND** Born 1946, New York City. Engineer. Developed computer system for WNET-TV (Channel 13), New York City, in association with Nam June Paik. Founder and technical director of WPA theater, New York City. Beginning in 1972 designed and produced custom video circuitry and patented several designs. Currently President of Imagine That, Inc., San Jose, California.

**DAVID BEHRMAN** Born 1937, Salzburg. Well known electronic music composer, long time association with Sonic Arts Union. Performed with John Cage, David Tudor, Frederic Rzewski and the Merce Cunningham Dance Company. Producer, series of contemporary music recordings CBS. Lives New York City.

**CLOUD MUSIC** is an installation developed collaboratively during the years 1974 to 1979. It consists of a video camera (black & white 1974-78, color thereafter), which scans the sky; a video analyzer, which sense the changes in light produced by passing clouds; and a home-made electronic sound synthesizer, which responds musically to the passage of clouds overhead. For this historical exhibition a black and white camera is being used.

## EXHIBITION HISTORY

1974 Canadian/American Sky, Electric Gallery, Toronto.  
1976 Experimental Television Center, Binghamton, N.Y.  
1977 The Annual, San Francisco Art Institute at Fort Mason.  
1979 Re-visions, Whitney Museum of American Art, N.Y.  
1979 Fur Augen und Ohren, Akademie der Kunst, Berlin.  
1981 New Music America '81 Festival, San Francisco.

## CLOUD MUSIC

Video camera (A) points at the sky.

Specially designed video analyzer (B) superimposes six electronically generated crosshairs upon the video image. Each cross hair may be positioned anywhere.

Composite image (sky plus crosshairs) is sent to the video monitors (C).

The video analyzer generates six control voltages. Each voltage is proportional to the instantaneous light value at the point where one of the cross

hairs is positioned. As cloud surfaces pass these six crosshair points, the voltages vary in response to the clouds' light content.

Digital electronic music system (D) receives the six voltage outputs from the video analyzer. The music system senses voltage changes made by the analyzer and converts the changes into harmonic progressions and dynamic shifts.

Sound from the music system is sent to a six channel loudspeaker system (E). The loudspeakers surround the viewing space and the video monitors.

Cloud Music is intended for installation during times of the year when weather conditions favor a likelihood of high daytime cloud activity.

**BOB WATTS:** "I discovered when I first arrived in New York City in 1946, from the midwest, that I no longer had the same visual access to the sky. It was apparent that no longer could I judge the weather by checking out the sky morning and evening as was my custom. I considered this to be a handicap to my accustomed life style, and still do. This incident shocked me into the recognition that the sky was an important aspect of daily living and that it was important to me to be able to see it whenever I chose. Sometime later, some fifteen or twenty years, the sky (as clouds) made a more direct appearance in my work as an artist, in multiple exposures on movie film and photographic montage.

Since 1965 clouds, sounds, indeed the whole phenomenology of the natural environment has

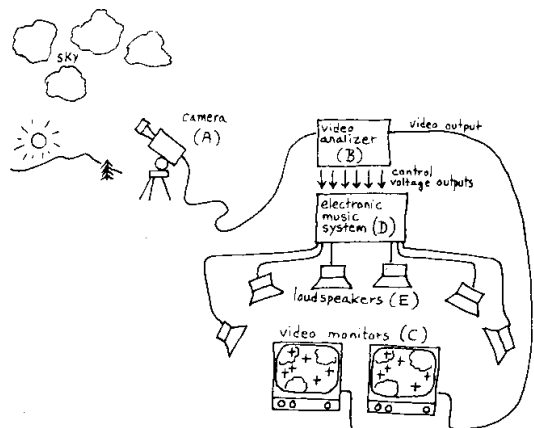

Diagram and summary, ca. 1975, David Behrman.



Bob Diamond with CLOUD MUSIC, work in progress, ca. 1976. Video analyzer (rear left) and music synthesizer (foreground).



FRAME 160 step through next 5 frames

pervaded most aspects of my work. This present work has been evolving since 1966 when at Rutgers University we made some experiments with a sound device that reacted to changing light intensity on a movie screen. At that time, I saw applications to my interest in clouds and the changing light of the sky. Early experiments showed possibilities but my hunch was that I should explore more sophisticated electronics, hopefully the missing miracle ingredient. My hunch proved correct.

The assistance of Bob Diamond and David Behrman was enlisted to expedite this project. Without their contribution, realization of the Cloud Machine would have been quite impossible."

**BOB DIAMOND:** "I began to see that to really correlate an (sound) environment with the clouds a la Bob Watts would involve a very sophisticated electronic system. We agreed that we needed some sort of video system that would scan the clouds as they moved by and produce a control voltage proportional to the brightness of the cloud of the scan point. This voltage could be used to vary environmental qualities of a space. The method I developed to do this relies on the fact that a video signal has an associated time-base or sync signal. This signal synchronizes the sweeping movement of the electron beam in a TV picture tube with that in a TV camera. The beam sweeps across the screen in a 63.5 or so microseconds for 525 times to make the complete picture or frame in 1/30 second. I could take a "snapshot" of a particular point in the frame by timing how long the beam took to set to that point and taking a sample of the video signal at the time-out point. The amplitude of the video signal would

be proportional to the brightness. Thus the voltage is held until the next frame when a new voltage is held, etc. By changing the time-out period, the sensitive point can be moved to any part of the picture. To facilitate finding this "point" another video signal is generated and superimposed on the incoming video signal. The total signal when displayed show the original image with six crosshairs superimposed, indicating where the sensitive points lie."

**DAVID BEHRMAN:** "For the sound, the outputs from Bob Diamond's video analyzer are used to create an interweaving of slowly shifting, multi-layered harmony that parallels the movement of the clouds. The technical means by which the passing of the clouds can be used to make music around a listener are of the 1970's - because only in the last several years have the sensory, logic, and video circuitry become easily accessible to individuals such as ourselves. But in spirit the project might be close to the old outdoor wind and water driven musical instruments of Southeast Asia and Polynesia.

Sound is produced by eight banks of audio-range function generators, four to a bank, each of which is tuned to a pre-selected four-part "chord" made up of pure modal or microtonal intervals. Six of the banks can each be detuned to four parallel transpositions by an output from the video analyzer. Any harmonic change corresponds to a minute change in light of crosshair in the video image.

Like sailing, the music is weather-dependent."



CLOUD MUSIC monitor with image of 6 crosshairs amidst lively cloudscape.



INFO frame 42318 to 45561



STEP BACK



STEP FORWARD



TAPE LIST

Artist	Title	Year/Dur
<b>Barron, Ros</b>	<b>ZONE: HEADGAMES</b>	69/ 7:15
<b>Beck, Stephen</b>	<b>CONCEPTION</b> <b>METHODS</b>	72/ 6:08 73/11:18
<b>Boyer, Jean-Pierre</b>	<b>INEDITS</b> Music: J. Coltrane and Eric Dolphy <b>RETROACTION BIOLOGIQUE</b> (excerpt) <b>BIOFEEDBACK</b> <b>L'AMER-TUBE</b> Music: Henry, Pierce, Risset <b>LE CHANT MAGNETIQUE</b> <b>L'EAU D'OUBLI</b> Music: Maxfield, Henry <b>PHONOPTIC</b>	75/ 7:06  73/ 3:32 74/ 2:55 73/ 6:30  73/ 7:02 73/ 5:39  73/ 2:30
<b>Crown, Peter</b>	<b>BIOFEEDBACK</b> (excerpt)	73/ 1:00
<b>Crutchfield, Jim</b>	<b>SPACE-TIME DYNAMICS IN VIDEO FEEDBACK</b>	84/16:00
<b>Devyatkin, Dimitri</b> w/ John Rogers	<b>VIDEO TUNNEL</b> (excerpt) Music: Robert Ashley	71/ 4:00
<b>DeWitt, Tom</b>	<b>PANTOMATION</b> (excerpt)	79/ 3:50
<b>Emshwiller, Ed</b>	<b>SCAPEMATES</b> (excerpt)	72/ 3:40
<b>Etra, Bill</b>	<b>BEDSHEET</b> (excerpt)	73/ 1:48
<b>Gusella, Ernest</b>	<b>EXQUISITE CORPSE</b> <b>ABSTRACT IMAGES</b> (excerpt)	79/ 8:30 72/5:40
<b>Gwin, William</b>	<b>Irving Bridge</b> (excerpt) Music: Warner Jepson	72/4:00
<b>Harrison, Lee</b>	<b>SONAR DISPLAYS</b> (selection) <b>EARLY SIXTIES ANIMATION</b>	68/ 5:00 —/9:00
<b>Hays, Ron</b>	<b>PAIK/ABE EXPLANATIONS</b> <b>LOVE/DEATH</b> (excerpt)	77/ 5:40 77/ 4:10
<b>Hearn, Bill</b>	<b>VIDIUM</b> (selection)	70/ 3:00
<b>Hill, Gary</b>	<b>OSCILLOSCOPE ENVIRONMENT</b> <b>VIDEOGRAMS</b> <b>ELECTRONIC LINGUISTICS STUDY I</b>	75/ 8:32 80/ 6:26 77/ 3:47

<b>Hocking, Ralph</b>	<b>STUFF</b>	76/ 4:00
	<b>STUFF</b>	76/ 2:30
	<b>SCRAMBLED LEGS</b>	77/ 4:15
	<b>TANTRUM</b>	77/ 6:00
<b>Jones, David</b>	<b>A TAPE FOR RALPH &amp; SHERRY</b> (excerpt)	77/ 8:38
<b>Juchno, Art</b>	<b>HAND</b> (excerpt)	77/ 4:30
<b>Morton, Phil</b> w/Jane Veeder w/Jane Veeder w/Gunter Tetz and Bob Snyder	<b>PROGRAM #9</b>	78/28:43
	<b>WITH TIMOTHY LEARY</b>	78/22:40
	<b>IEVE</b> (Interactive Electronic Visualization Evening)	75/ 4:00
<b>Nettles, Patty</b>	<b>WARP FIVE</b> (excerpt)	78/ 3:00
<b>Nam June Paik</b>	<b>VIDEO VARIATIONS</b>	72/ 2:27
<b>Perlman, Philip K.</b>	<b>THOUGHT MORPHOLOGY</b> (excerpt)	73/ 1:16
<b>Sandin, Dan</b>  w/The Vasulkas w/Tom DeFanti and Bob Snyder	<b>THE IMAGE PROCESSOR</b>	73/ 7:03
	<b>THE FIRST DIC TAPE</b>	78/ 3:32
	<b>DIALOG WITH THE VASULKAS</b>	78/12:00
	<b>PEANO</b> (Performed Live at IEVE)	75/ 3:00
<b>Seawright, James</b>	<b>VIDEO VARIATIONS</b> (Music: Arnold Schonberg)	72/ 7:27
<b>Seawright, James</b>	<b>CAPRICCIO</b> (Music: Bulent Arel)	69/ 6:14
<b>Siegel, Eric</b>	<b>EINSTINE</b> (Music: Rimsky-Korsakov)	69/ 5:41
	<b>TOMORROW NEVER KNOWS</b> (Music: The Beatles)	69/ 3:10
	<b>PSYCHEDELEVISION</b>	68/22:54
	<b>PETER SORENSEN</b>	68/ 1:00
<b>Snyder, Bob</b>	<b>WINTER NOTEBOOK</b>	76/10:53
<b>Sweeney, Skip</b> w/Larry Hankin w/Doug McKechnie and Bill Hearn	<b>VIDEO FEEDBACK</b> (selection)	69/ 4:15
	<b>VIDIUM/MOOG</b> (selection)	70/ 4:49
<b>Tambellini, Aldo</b>	<b>BLACK TAPE</b>	69/ 4:00
<b>Wright, Walter</b>	<b>DOLPHIN EXPLANATION</b>	72/ 7:18
	<b>MAHAVISHNU</b>	72/ 4:53
<b>Zagone, Robert</b> w/Charles Olson w/Robert Creeley w/Jo Ann Kyger w/Janis Joplin w/John Graham	<b>“SHOWCASE”</b>	68/ 3:10
	<b>MAXIMUM LETTER NUMBER WHATEVER</b>	
	<b>1-2-3</b>	68/ 1:00
	<b>DESCARTES</b>	68/11:00
	<b>BIG BROTHER &amp; THE HOLDING COMPANY</b>	68/ 6:57
	<b>DANCE DELAY LOOP</b> (excerpt)	68/ 1:00
<b>The Vasulkas</b>	<b>SELECTIONS</b>	69 to 79



# R E L A T E D D O C U M E N T S

This final section of the catalog includes a selection of related documents chosen for their explanatory or historical relevance. While they are not correlated to the laser disks directly, they often comment further upon topics related to the exhibit and its interactive supplements.—D.D.



# IMAGE PROCESSING AND VIDEO SYNTHESIS

## Electronic Videographic Techniques

Stephen Beck

1975

**I. *Electronic imaging techniques.*** These techniques as applied to television utilize the inherent plasticity of the medium to expand it beyond a strictly photographic/realistic, representational aspect which characterizes the history of television in general. A wide variety of electronic instruments have been constructed by engineers, artists, and engineer-artist collaborations in the past several years which operate specifically with TV sets as primary display or "canvas." Each imaging system which has been developed reflects the artistic and technical capabilities of its originators, and tends to be utilized according to distinctly different aesthetic theories. In some cases the resultant image is largely due to the inherent circuit designs of a given instrument. In other cases, the instrument is utilized to produce an image with a specific visual or psychological effect, the electronic aspect being more of a means than an end to the realization.

Regardless of the specific aesthetic usage of particular instruments, some insight may be obtained by examining the structural differences and similarities between typical video synthesizers and image processors, as well as some of the basic circuitry which is used in these devices. In every case, the video synthesizer may be viewed as a "tip of the iceberg" of electronic technology & visual arts. Vast armies of individuals make the transistors, resistors, capacitors, and integrated circuits which comprise a synthesizing instrument, when properly applied under the design of visually inclined electronic artists.

**II. *Categorical distinctions of electronic video instruments.*** Just as in the science of biology, where many classifications of lifeforms exist, there are several genre of video synthesizers. In the sense that a synthesizer in general is something which combines parts to form a whole entity, just about all video

instruments could be classified as such. However, in terms of structural details, some clarification can be made. I have listed: several categories of video image instruments according to the unique qualities of their principle of operation, some criteria for making the distinction, and artists and engineers in the video art field who are using these methods.

**1. *Camera image processor types.*** These types include such techniques as colorizers which add chrominance signal to black and white (monochrome) signal from TV camera; keyers and quantizers which separate value levels in a scene and allow other processes to take place in that scene, add synthetic color, place another image in certain places of the original, obtain matte effects; modifiers which do not alter the geometry of the image but rather affect its grey scale, such as polarity inversion, or which generate an edge around elements of the image, or which mix by superimposition several image sources. Systems that are essentially of the image processor type described include those built by Paik/Abe, Siegel (CVS), Templeton, Sandin, Hearn, Vasulkas, and others.

**2. *Direct Video synthesizer types.*** These types are in principle conceived to operate without the use of any camera image, though some of them can also perform the processing operations described above. Basically, a complete TV signal is formed from electronic generators which comprise the synthesizer circuits, which include circuitry such as *color generators* which produce chrominance signals according to either I-Q methods, Hue-Saturation methods, or Red-Green-Blue methods; *form generators* which establish the necessary pulse vibrations to produce shapes, planes, lines, or points and to move them in various ways by use of *motion modulators* with either simple electronic waves such

as ramps, sines, or triangles, or more complex curves, or even with audio frequency sound signals; *texture amplifiers* which allow for color manipulation to achieve shading, chiaroscuro, "airbrush," or granulated effects, roughly could be thought of as electronic brush effects. Instruments using the Direct Video process include those by Beck (Direct Video Synthesizer), Siegel (EVS), Dupouy (Movicolor), EMS (Spectron), and others.

**3. Scan modulation/Re-scan types.** These rely on the principle of a TV camera viewing an *oscilloscope* or *television screen* which displays the image from another TV camera. The image on the screen can then be manipulated geometrically (stretched, squeezed, rotated, reflected, etc.) by means of *deflection modulation*, either magnetically or electronically. The second TV camera then transforms this image into one bearing a proper TV scan relationship, and may then be colorized or processed by techniques outlined in section 1. These systems can also be used without an input camera where the image then consists only of the manipulation of the raster, producing Lissajous type images. Systems using this method include those by Harrison (Computer Image), Paik/Abe, Rutt/Etra, and others.

**4. Non-VTR recordable types.** These types are included for completeness and encompass those video displays which do not actually produce a standard TV signal waveform and can hence only be utilized on one set which is specially prepared, and cannot be directly recorded on magnetic video tape. Most are based primarily upon magnetic distortion of the normal TV scan pattern, or else they utilize a color picture tube as if it were an oscilloscope screen. Such individuals as Paik, Tadlock (Archetron), and Hearn (Vidium) have utilized these techniques in their video sculpture.

I have not included in this categorization the studio switcher and special effects generator to be found in most teleproduction studios, which include processing and wipe generation, or the emerging video game box which is in principle a direct video signal generator of very specific configuration. Nor have I alluded to video feedback techniques, which all systems are capable of sustaining in one of its various forms.

In every case the individual approach to video instruments encompasses a wide variety of circuit designs and processes. Some require cameras, others

do not; some utilize a form of voltage control which permits color changes, image size, or movement rate, for example, to be changed by some other circuit, in addition to being changed by an operator. This factor introduces an interesting dilemma into the realm of electronic images: how much is the image a product of the instrument rather than of the instrumentalist?

A video synthesizer can be set to conditions which generate image after image for hours upon hours—perhaps interesting, perhaps not—depending upon the viewer. But in this case the images have their composition in the circuit design and programming of the instrument. Or the image may be altered and shaped temporally by someone playing the video synthesizer, in which case the images have their composition in the mental image of the player, interacting with the circuit design.

One can conceive of a synthesizer as a generative device which forms the resultant picture by a process of assemblage of electronic pulsation, or one can conceive of it as a filtration device in which, due to the proper selection of numerous electronic conditions, a given image out of the infinity of possible images results as a picture. Giordano Bruno in his thesis "*De Immenso, Innumerabilibus et Infigurabilibus*" postulates an infinite number of universes which are perceived by a selective process to form a reality distinctly unique to the viewer. Thus it is that a video synthesizer and Marconi Mark V color studio reveal very different images—each is filtering according to very different criteria—neither one more or less valid.

When visual literacy has advanced sufficiently, many will no longer consider the synthesized image as a by-product of television technology, but as a visual reality of its own, distinct from the terms of a representational, photographic image, an image which is more glyphic than literal.

**III. Two examples of video synthesizer circuit structures.** In order to illustrate in more detail some typical electronic techniques utilized in video synthesizer and image processor circuits I shall mention the comparator circuit and colorizing techniques.

The comparator is a very general circuit used in keyers, quantizers, wipe generators, and form generators. It is symbolized electronically as a triangle enclosing a question mark:

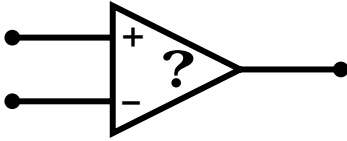

There are two inputs and one output. The inputs can be continuous voltages from, say, a scale of 0-10. The output however is allowed only two conditions: ON or OFF. The appropriate condition is determined by comparing the values of the two inputs. If the + input value is greater than the - input value, the output is ON; if the + input is the same as or less than the - input, the output is OFF. A typical circuit used for this function is the u710 integrated circuit, about the size of a dime.

When the continuous voltage to one input comes from a monochrome TV camera, the value 0 represents any black areas in the image, while the value 10 represents the brightest white areas in the picture, with value 5 representing an area of medium gray. Imagine the image to be a white cross inside a gray square surrounded by a black background. The image could be depicted schematically as

```

0 0 0 0 0 0 0
0 0 5 5 5 5 0 0
0 0 5 9 9 5 0 0
0 0 9 9 9 9 0 0
0 0 5 9 9 5 0 0
0 0 5 5 5 5 0 0
0 0 0 0 0 0 0 0

```

If the other input to the comparator comes from a fixed value source, called the *threshold*, then the resultant circuit is a simple keyer. The output will be OFF whenever the picture element is less than the threshold and will be ON whenever the picture element is more than the threshold.

For example, the white cross could be colorized by setting the threshold to say value 7 and connecting the output of the comparator to a colorizer activated circuit. Only where the picture value exceeds value 7 will the color be turned on, in the region occupied by the cross. If another comparator were introduced with its threshold set to value 4, then the output would be ON in the region occupied by the gray box and the white cross, and it could be used to control a second colorizer producing a colored square, which might be combined with the colorized cross. If the two inputs to comparator 2 were exchanged, then the color would be inserted into the area surrounding the gray square.

Clearly this example can be extended to many

channels, 8 or even 16 not being uncommon, and forms the basis for quantizing colorizers and multiple level keyers used by some video artists. Bear in mind that the scanning process traverses each line of picture elements in some 52-millionths of a second, with each element being occupied for only 250 nano seconds (billionths of a second) so that comparison must be performed very fast. The u710 can make a comparison in less than 20 nano seconds. But at this high speed, and when the picture and threshold levels are almost equal (within a few thousandths of a volt) the output often is indecisive, oscillating back and forth for a time, producing the speculated or "torn" edge characteristic of keying.

### Colorizing.

In television color, three types of phosphors are applied to the inside surface of the picture tube; each emits a different color light when excited by electrons scanning over them. The three colors are red, green, and blue, and are applied in either triadic clusters of tiny dots, or in very thin strips, so that at normal viewing distances the individual phosphors are not discernable as such, but tend to fuse their colors according to the subjective process of color vision. Each of the primary colors can be varied in intensity from zero to 100% by modulating the intensity of the electron streams exciting them. In this manner, polychromatic reproduction is achieved by controlling the admixture of three primary colors. Since the color process is additive and involves the mixture of emitted light, all three colors when excited in equal amounts produce the sensation of white or gray values. When just the red and the green colors are stimulated, a yellow color is sensed, or when red and blue are excited, purples result.

The three properties of color include *hue*—the wavelength of the color (i.e. yellow as opposed to green or blue); *saturation*—how intense or vivid is the hue; and *brightness* or *value*—how much is the color diluted or made pastel by the addition of white or gray. Any video colorizer must determine each of the three properties. In black and white television (more properly known as monochrome) the picture is composed entirely of various intensities of light of a bluish-white nature. This signal is known in television terminology as the luminance signal. It conveys information of values. With color television an additional information bearing signal is used to convey the hue and saturation information, called

the *chrominance* signal or chroma.

This chrominance signal is present in the form of a color subcarrier which vibrates at 3,579,549 cycles per second. Its intensity or amplitude is varied according to the saturation of the color, and its phase is varied according to the hue of the color. This technique of phase modulation requires the presence of a pilot or reference signal to supply the phase angle reference, known as the color burst.

In essence, the color spectrum may be visualized as occupying a circular distribution. The center of the circle represents no saturation, while any distance outward from the center represent progressively more saturated colors with the direction representing the hue of the color. In fact there are actually two elements of the color subcarrier which can be controlled to produce synthetic color; the I and Q components, standing for inphase and quadrature.

The simplest colorizers operate on the hue-saturation principle, with one control affecting the phase of the color subcarrier and thus determining red, yellow, green, cyan, blue, or magenta hues, while the other control affects the amplitude of the subcarrier to determine the vividness or saturation of the desired hue. An additional control may be added electronically to an existing monochrome signal derived from a camera.

Another type of colorizer operates by modulating the intensity of the I and Q subcarrier components. The combined effect of two independent modulations generates both hue and saturation information, with the two variables being affected simultaneously. Thus to change the vividness of a given hue, both controls must be changed together.

A third type of colorizer circuit is the Red-Green-Blue encoding method. Three controls determine the saturation levels of red, green, and blue primaries, which then mix in the encoder to produce luminance and chrominance signals of the standard video signal. Besides operating in a graphic mode, this type of colorizer is readily adaptable to other TV systems in use by substituting the encoding circuitry. The I/Q and Hue/Saturation methods normally require different techniques for each type of television system used.

Many colorizers are limited to full screen color or quantized color type of operation. This allows for basically hard edge color. In the Beck Direct Video synthesizer I have been particularly interested in surmounting this limitation and achieving a full range of color contouring.

**IV. Video synthesis and computer graphics.** In the strict sense of the word, a digital computer is but a large collection of electronic switches arranged to operate on binary bits of information. As such, most video synthesizers do not qualify as computers; although the analog computer, with op-amps, differentiators, integrators, and amplifiers more closely resembles the structure of video synthesizers. Computer graphics generally has been done with oscilloscope displays under computer control, though some newer systems do generate images on a color television display directly. We can expect to see the use of digital computers in the control of video synthesizers via means such as digital to analog converters. When one compares the bandwidth of video images (4,200,000 cycles per second) with computer processing speeds (500,000 bits per second typically) or with audio signals (20,000 cycles per second) the gap between computer output speeds and the necessary information rates to generate a moving video image becomes apparent.

In terms of circuit devices, most video synthesizers and image processors utilize discrete transistors and some types of integrated microcircuits. We can expect to see the emergence in two or three years of video-integrated circuits designed specifically for the imaging functions of television display.

Video synthesizers consume electrical power of from 50 watts to several hundred watts—far less than even a single spotlight utilized by the dozen in standard camera studios. They also require far fewer personnel to operate them when compared to standard teleproduction. Both of these factors make video synthesized television images appealing from an economical perspective.

**V.** The appearance of electronic imaging instruments such as the video synthesizer and image processors ushers in a new language of the screen. Non-representational and departing from the conventional television image, these methods will stimulate the awareness of new images in the culture. Any growth of the video-synthesized image will be contingent on the ability of video artists to become proficient in techniques of composing and presenting synthesized imagery. The instruments themselves will not perform without the artistic consciousness of a skilled operator.

# The Video Synthesizer

Tom Dewitt



NANO B frame 245 to 6955

*Below are excerpts from a late 1970's paper by Tom Dewitt describing an enhanced video synthesizer called the "Design Device." This proposal reviews video synthesizers of its day, touching on their principles and limitations in waveform generation, colorizing, signal routing, and image display through XY deflection. The suggested enhancements form a technical sketch, to synthesize a video art tool for use by independent video artists. —J.S.*

This proposal describes a new kind of video synthesizer which uses the graphic potential of the video medium for a programming language. The instrument, called the Design Device, will perform video synthesis and signal processing under control from a mini-computer which reads a specially formatted picture language. This programming language will permit artists to prepare ideas away from the studio and provide a permanent record on paper of all useful programs.

## Review of Existing Video Synthesizers and Ideas for a New One

To free the video artist from the confines of the real camera-recorded world, it is necessary to develop instruments which generate a television compatible signal from raw electronics. A synthesizer is the paint and palette of the video artist, a device which lets the artist construct spaces from the dictates of imagination.

The first video synthesizers began to appear almost a decade after the development of complete audio synthesis systems. There are compelling reasons for this delay. The development of a time variant artform is just now being born in the visual arts, centuries after the establishment of a related set of time variant structures in music. Technically, the video synthesizer is more complex than its audio cousin. Video signals cover a frequency spectrum

100 times greater than audio and must be constructed according to a precise timing synchronization which does not exist in the one dimensional audio signal. Consequently, design concepts and instrument components are now coming together for the first time.

There have been two approaches to video synthesizer design: vector graphics and signal intensity. This split is a consequence of the television system itself which uses a one dimensional high frequency signal to describe a two dimensional field of much lower frequency. The systems developed by Steve Rutt and Bill Etra, Computer Image Corp., Vector General, and others operate on the x and y deflection amplifiers of a cathode ray display. The synthesized or processed images coming from these devices are rescanned by a conventional camera for recording on video tape. Synthesizers, on the other hand, such as those developed by Stephen Beck, Dan Sandin, and EMS Ltd., operate on the intensity or "z" component of the video signal. Their output is made compatible with video standards by a *processing amplifier* or through a *color encoder*. The two approaches can be combined in a single device. In fact, Sandin has worked extensively with a computer controlled vector display, and Rutt/Etra synthesizers are invariably teamed with keyers, colorizers and other signal processors. However, no one has come out with an integrated package that incorporates both approaches.

The artist designed synthesizers are "modular,"

that is, specialized devices are linked by patch cords which are manually inserted to complete a complex program. Modular design is essential in video, because it permits parallel and simultaneous processing of high frequency signals. The chief drawback of the general purpose computer in video synthesis is that it performs one operation at a time and cannot keep up with the video clock. As in the development of the audio synthesizer, engineers have provided artists with functional module building blocks which efficiently accomplish commonly needed functions. Modular design also permits a wide range of interconnections depending on the "patch" made between them. For example, a system of only 8 modules, each with a single input and a single output can be patched in over 40,000 different ways.

While modular systems provide both variety and efficiency, they also can present the artist with a confusing welter of two ended wires which makes live performance difficult and leaves him with no permanent record of his patch. The first step in improving this situation came with the introduction of the matrix switching systems of the Arp and EMS synthesizers, adapted for video by Woody and Steina Vasulka. These systems have manually set cross-points and permit patchfields to be recorded by graphic notation. Going a step further, Don Buchla and Bell Labs have developed computer controlled patchfields which are notated with a verbal language.

Existing video and audio synthesis systems use a building block called the oscillator. The most common technique for generating forms is called *additive synthesis* in which the output waveforms of oscillators are mixed to form a wave form which is the sum of their combined outputs. It is theoretically possible to duplicate any natural waveform by summing sine waves of different frequency. This approach has led to the construction of synthesis systems with dozens of oscillators. When such systems became untenable because of the large number of signal paths, a device was introduced by Don Buchla which generated a waveform from discretely set increments. This device is now known as a *sequencer*. It can be used as an oscillator or a controller in voltage controlled systems. Information is loaded into a sequencer manually by setting dozens of potentiometers. Like the patch cord system, it must be set up from scratch every time it is used. There is no convenient way to notate for this

device. The general purpose computer can be used as a kind of sequencer since its memory stores lists of numbers, but again the problem of cycle time limits its use to low frequencies. Recent innovations in semiconductor technology, however, have put digital memory within the reach of the video synthesizer. Using modular design techniques, it is possible to build an oscillator module with a programmable output. The stored waveform is loaded from a sampled graph drawn by the artist and scanned by a conventional television camera. Given that this small memory can serve to store waveforms, a method must be found to clock out its stored information. Oscillators such as those found on the Rutt/Etra or Stephen Beck's synthesizer must be synchronized to the rest of the synthesizer in order to produce stable patterns. While it is relatively easy to make a voltage controlled oscillator, it is difficult to maintain synchronization for an analog module.

The most common "special effect" available on commercial switchers is the geometric pattern called the wipe. The technique for generating wipes is quite straightforward and is used by Beck and others in artist oriented synthesizers. The pattern of the wipe is formed by the waveshape of an oscillator, and such wipes as diamonds, ellipsoids, and boxes are easily formed with an analog oscillator. The memory oscillator of the Design Device will permit virtually any shape of wipe to be made, and there will be provision for making multiples of any shape.

One of Steve Beck's contributions to video synthesis was a perceptive analysis of spatial composition. By dividing the image into components of point, line and volume he was able to design modules to achieve each objective. Among his inventions were devices that took complex images and reduced them to these spatial elements. In many ways, this paring down of images is important because it allows the artist to simplify complex spaces and combine them inside a single frame. The Design Device will contain an outline generator which will reduce volumes to lines. This will permit many shapes to be seen through each other.

The unique advantage of vector graphic systems like the Rutt/Etra synthesizer is its ability to reposition an image after it is recorded. Among the manipulations possible on such a system are electronic zooming, left-right inversion, top-bottom inversion and rotation. The Design Device will have processing modules which will permit all of the

above effects. The rotation function is not normally available with commercially sold Rutt/Etra systems because it requires a low frequency sine-cosine generator. This pair of precisely timed control voltages will be available in the Design Device through its memory oscillators.

At the beginning of this discussion of video synthesizers, I called such devices the artist's paint and palette, and no module better fits this description than the colorizer. There are many designs for colorization devices both commercial and unique. In systems which use a camera encoder to generate the final output, the colors are determined by mixing, red, green and blue components. While pleasantly reminiscent of mixing colored paint, this system is less efficient to use than the colorization made possible by video color parameters: luminance, chrominance and hue. With the latter system it is possible to pass a previously encoded color signal through the synthesizer and recover it unchanged at the other end (through the luminance channel). New colors can be added by entering signals into the hue and chrominance channel. Where gray scale encoding is used such as in quantization, the single hue parameter can produce rainbow-like effects. The Siegel colorizer uses gray scale encoding to modulate all three parameters simultaneously. Dividing the inputs into three channels gives an increased degree of control over the final output. The Grass Valley colorizer uses the luminance, chrominance, and hue parameters but is not voltage controlled and hence is not dynamic.

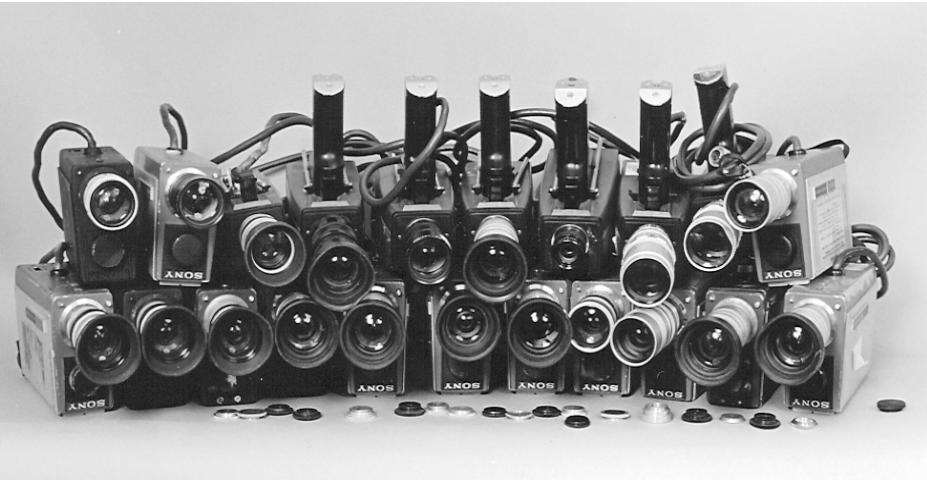



# IMAGE PROCESSING

Experimental Television Center, 1986

Sherry Miller Hocking  
& Richard Brewster

*The following are excerpts from the Experimental Television Center (ETC) in Owego, N.Y., "Image Processing Manual." The manual was written in the early 1980's by Sherry Miller Hocking, in collaboration with Richard Brewster, and is an outgrowth of a prior "how-to" manual in 1976, cataloguing the video equipment at ETC.*

*The manual contains a review of fundamental video principles contained in waveforms, timing and synchronization. It acts as an educational and training vehicle for reference by visitors to the Center, but also includes descriptions of unique video art tools and how to use them. These depictions are accompanied with an underlying ideology: that informed exposure to the language and expressions of technological art tools will point toward their creative use in the video arts. — J.S.*

**SIGNALS:** As a kinetic as well as an electronic form, video concerns itself with the time/space equation. Video image movement occurs within a predetermined space, and the process of change, by definition, is a temporal event occupying a specific length of time. Changes in the time frame or time base of the signals which define the image result in changes in the duration of images and in the locations of sections of images within the two-dimensional space of the image's display. On the level of electronics, the very construction of the video image, its generation as well as its display, is time dependent. The composition of the signal, then, defines the visual nature of the image as it exists in time; it dictates both the appearance of the single "still" image, which exists within a specific length of time, and its behavior through time.

On a primary level, the signal can be viewed as the art-making material; the creation of an electronic image is an architectural process and constructed in time. The signal refers to changes in energy levels and reveals a physical nature by forming and influencing images. Specific devices in an electronic image processing system perform specific functions or operations on signals, generating and altering the signals, or codes, and therefore the resulting images. In this way the hardware of the system can be viewed, in part, as a "carrier of

aesthetic definitions." There are several general categories of signals specified by the processing system which include video, audio, control, and synchronizing or timing signals; as shall be seen, signals may perform functions within several categories. One signal, for example, can influence an image and also produce a sound. The term "signal," derived from the Latin *signum* meaning sign, refers in a general sense to the use of conventional symbols which refer to a verbal description of a concept or event. A signal then is a translation of the description of an event from one set of symbols to another set of codes. It is the representation of the event. The signal conveys information concerning the state of the event in any given instant through time. Video images are codes of information conveyed by signals. The specific video picture information conveyed by a signal is in the form of changes in voltage; changes in voltage dictate changes in the information being carried. Voltage changes can be categorized in terms of changes of strength, increased or decreased voltage, and changes of direction, alternating or direct current signals.

**Electricity** is usually defined as the orderly movement of electrons through a conductive material. When a voltage is applied to a conductor, a force field is established which causes electron move-

ment and therefore electrical energy. The rate at which electrons move past a given point is a measure of current strength expressed in amperes or amps. When a current of one amp flows through a conductor,  $6 \times 10^{18}$  electrons are passing a given point each second. Electrons move only when an unbalanced electrical force or potential difference is present; voltage is a measure of the force causing electronic motion and is often described as electrical force or pressure. Ground is a reference point which has zero potential energy or zero volts. Because of the properties and dimensions of the conductive material, there is a resistance to the flow of electrons. Resistance is often likened to friction and is measured in ohms. It refers to the impedance of a current flow and results in the dissipation of power in the form of heat. Although the degree of resistance is dependent on the nature of the material, the resistance of any given material is constant.

**Ohm's Law** expresses the relationship between current, resistance, and voltage; it states that voltage equals current, measured in amps (I), multiplied by resistance, measured in ohms (R). Because the resistance of material does not change, voltage is proportional to current. Increases or decreases in voltage simultaneously produce proportional increases or decreases in current. A watt is a unit of electrical power produced when one volt causes a current of one amp to flow through a circuit.

Two of the effects of electrical current are heat and magnetism. The resistance of the conductive material to the flow of electrons produces heat; this is easily demonstrated by the warmth of an incandescent electric light bulb. An electrical current also induces a magnetic field; this can be seen in the deflection of a compass needle placed near a wire through which a direct and steady current is flowing. The force of the magnetic field is at right angles to the direction of current flow. Michael Faraday in 1822 demonstrated the reverse of this law by showing that an electrical current can be induced by a magnetic field. A flow of electrons can thus produce a magnetic field and is also produced by a magnetic field; a magnetic field can therefore be employed as a means of controlling the movement of a flow of electrons, a process basic to the functioning of the scan motions in a video camera or monitor and also

the foundation of many scan processing devices.

Electrical signals have a **waveform** which conveys the time limits of the event, the strength of the event and the direction of change of the event relative to a base line or reference point. The electrical signal can be graphically displayed in a number of ways.

On a fundamental level the waveform of an electrical signal is displayed as an XY plot of voltage changing through time. By convention, the horizontal or X axis represents the time dimension and the vertical or Y axis represents the voltage or signal strength. An oscilloscope is a test instrument which visually displays any electrical signal as a change in voltage through time. A waveform monitor is a specialized oscilloscope which graphically portrays the composite video signal.

In discussing a black and white video signal, the range of the video or picture portion of the entire signal provides an indication of the relative brightness or darkness of the image represented by the signal. A higher voltage level measured on the Y axis indicates a whiter portion of the image while a lower level indicates a blacker portion of the image.

The concept of graphic representation of waveforms is crucial to the understanding of an image processing system. As we will see, the time dimension or time frame of the signal may be extremely brief as in the representation of a single line of the video image which occurs in  $1/15,750$ th of a second; the time frame may also be relatively long as in the representation of a frame of video, a collection of 525 lines which occurs in  $1/30$ th of a second. The basic XY format can also be extended to incorporate a third parameter represented along the Z axis which can be conceived of as a vector extending out into space. This notion is important to understanding the technique of colorization. Woody Vasulka developed a technique using this type of vector diagram to locate parameters of the time frame of a video image, employing the Rutt/Etra Scan Processor. This graphic representation defines the line rate, field rate and intensity information.

A waveform can be described in terms of its shape, the number of times it repeats per time unit, its strength, placement and direction.

A waveform may begin at any point but when it returns to the point past which it started, the

waveform has completed one cycle. Cycle refers to the completion of one rise, fall and return of the signal. It is important to note that the waveform may pass through a number of times the particular voltage at which it began before one cycle is completed. For example, the **sine wave** begins at the point exactly half way through one cycle before ending at this value at the second cycle after beginning. The time it takes for one waveform to be completed is called the period of the waveform. The term periodic refers to a waveform wherein a regular, repeating pattern is observable as the voltage changes through time; **sine**, **square**, and **triangle** are all periodic waveforms with specific shapes. Sine, square, and triangle are the basic waveshapes which can be combined with each other to produce complex waveforms. As we will see, the sine wave is actually the fundamental form from which square and triangle are derived.

**Noise** refers to a signal which is not periodic but random in nature, with unpredictably varying signal strengths; it is often defined as extraneous information present in the signal which is determined to be undesirable either through the process of comparing the signal to a reference signal or by personal decision. Noise can be manifested either aurally or visually and can also be used as a control. Snow is an example of video noise; snow is a random organization of monochromatic blotches and is part of the vocabulary of image processing because it is used as an image element in composition in much the same way that audio noise is used in electronic music composition.

The number of times a waveform is repeated per unit of time is called the **frequency** of the waveform; frequency then implies the speed of the signal. The number of cycles the signal completes in one second is measured in cycles per second expressed in **Hertz or Hz**.

The **amplitude** of the signal refers to the maximum strength attained by the signal. It is measured by the height of the waveform expressed in volts. The signal may have both a positive and negative voltage dimension. The reference line of zero volts is called ground. The total voltage excursion of the signal, obtained by the addition of the maximum positive and maximum negative points reached by the signal, is referred to as peak to peak voltage and

is abbreviated **Ppv**.

The term **gain** defines the total peak to peak voltage excursion of a given signal and indicates the relative strength of the signal. An increase in the gain of the signal causes an increase in the signal level and conversely, a decrease in the gain results in a decrease in the signal level; gain thus equates with the amount of amplification of the signal. It expresses the ratio of the amplitude of the input signal to the amplitude of the output signal.

The term **attenuate** means to reduce in force or intensity; with respect to an electrical signal; attenuation refers to the lowering of the amplitude of the signal with respect to ground. Instantaneous amplitude refers to the distance between a specific point in the waveform and the base line or ground and is expressed in **volts**.

The signal can be further defined by its positive and negative voltage dimension. An AC or alternating current refers to a signal which has both a positive and negative voltage dimension. An AC voltage rises to a maximum point and then falls through zero to a negative voltage level which is equal in amplitude to the maximum. A DC or direct current voltage does not change direction; the signal does not vary and is always either positive or negative. Polarity refers to the existence of two opposite changes, one positive and the other negative. When a signal is inverted, the polarity of the signal is reversed. Positive signals become negative and negative become positive. In the case of a black and white picture signal, all the black become white.

The term **bias** indicates the repositioning of the signal relative to ground; the absolute amplitude and frequency of the signal are unchanged. The term **phase** refers to the relative timing of one signal in relation to another signal. If one signal is "in phase" with another, they both possess identical timing and have begun at the same instant.

A waveform may also be frequency and amplitude modulated. In amplitude modulation, the amplitude of the signal, called the carrier waveform is determined by the amplitude of a second control signal called the modulating signal which is input to a function generator. In this case, the frequency of the output remains the same as the normal output. The amplitude of the modulated or output signal changes in proportion to the amplitude of the modu-

lating or control signal. In frequency modulation, the amplitude of the output signal remains the same as the normal output signal but the frequency of the output signal is determined by the frequency of a second signal, the modulating signal, which is fed into the function generator. The change in frequency of the modulated signal is proportional to the amplitude of the modulating or control signal. **Modulation** refers to the process of changing some characteristic of a signal so that the changes are in step or synchronized with the values of a second signal as they both change through time.

In the process of **filtering**, certain predetermined information is masked off, allowing a specific portion of data to pass through unchanged while the remaining is eliminated. Most commonly, filters act on frequency ranges although they can also act on amplitude ranges. For example, a low pass filter cuts off high frequencies while passing low frequencies, while a high pass filter rejects low frequencies and passes high frequencies. The cut off frequency value can usually be controlled either by manual adjustment or with the technique of voltage control. A variable pass filter is actually a low and high pass filter working in series. The frequency range which passes is located between the cut off levels of the high pass and the low pass filter. The reverse process operates in a notch or band-reject filter. When the cut-off frequencies of both high and low pass filters connect in parallel overlap, the frequencies located between the two cut-off frequencies are rejected.

Signals can be further specified as **analog** or **digital** structures; the terms refer to ways of representing or computing changes which occur during an event. On a basic level, an analog signal is frequently explained as describing an event, a voltage for example, which continuously varies within its allowable range, ie. a thermometer. The measurement of the temperature is limited only by the resolution of the scale and how accurately the scale reading can be estimated. The position of the mercury relative to the scale markings must be estimated. Analog indicates that the signal as measured on a scale represents or is analogous to the information related by the signal. In a sense the scale represents the event. Analog devices use information which is constantly varying; within the

allowable range, any value can be input or output. Conventional video cameras are analog systems; the video signal continuously varies and represents a pattern of lights and darks at which the camera points. A video monitor is also an analog device, but the representation flow is reversed in direction. The pattern of lights and darks, the image on the screen, represents a continually varying voltage, the video signal. A sine wave is also an example of an analog signal. The sinewave oscillator is an analog system which is specialized; it always produces a specific waveshape, the sine wave.

Digital signals are frequently explained as signals which describe information consisting of discrete levels or parts. Digital signals are concerned with stepped information; the change from one value to another in a waveform does not vary continuously but, with some qualification, occurs instantly. Digital devices are constructed from switches which have only two states; they are either on or off, open or closed. All of the various voltage levels in a digital waveform must be expressible by two numbers, one representing the off, closed or low state; and the other representing the on, open or high state. One point of an event or voltage can be represented as a series of open or closed switches; the number of open and closed switches is counted, and this information is translated to one value. A number of these values can thus be constructed which will eventually plot a complete waveform. A digital waveform then has a stepped, square-edged appearance; the **square wave** is a simple example of this type of signal.

Several number places may be required to express a complex digital signal. If we have a number with one place and each place can only be a zero or a one, then we can use this number to express one of two states; 0 and 1. If we have two places and each place can be either zero or one, then we can express four different states: 00, 01, 10, 11. The number places are called bits, a contraction of binary digits. The large number of combinations mathematically possible using only two numbers and a given number of places allows for the expression of many signals. Many electronic image processing systems have both analog and digital components and are often described as hybrid systems. It is important to note that with analog signals the waveform or one

characteristic of the waveform is manipulated. With digital signals, the information about the waveform is altered and then used to reconstruct the waveform.

A signal then conveys certain information about an event. It contains a number of variables, such as frequency, amplitude or placement which can be changed and controlled. Control over these variables is an issue central to electronic image processing. Whether achieved by manual or automatic means, control is exerted on a signal which defines an image and not the image itself. The achievement of control over the signals which define images is important to the use of electronic imaging as an art-making medium.

A **potentiometer** or **pot** offers manual control over voltage through the adjustment of a knob. A familiar example of a pot is the volume control on a television receiver. Turning the knob results in an increase or decrease of the amplitude or the audio signal and thus an increase or decrease in signal strength or loudness. A pot allows only a continuous type of change over a signal. It is not possible to move from one discrete setting of a pot to another without proceeding through all the intervening voltage levels. On a basic level, a pot provides a method of manual control over the signal; the rate of change can be altered but is limited by the speed at which the knob can be turned by hand and the process of change is always continuous. A pot has three connection points or terminals. Two of the terminals are connected to a material which resists signal flow. The position of the third terminal, called a wiper, is adjustable along this resistive material. By changing the position of the wiper by manual adjustment of the knob, the amount of resistance to current flow is changed and therefore the signal. Frequently pots are calibrated, often by a series of relative number settings; because the change is continuous, the resolution of the scale to some extent determines the accurate repeatability of the manual setting.

Control over signal parameters can also be achieved by exerting an automatic rather than manual control over the pots. The technique of voltage control in effect allows the pots to be adjusted by another voltage rather than by hand. The principle of voltage control is the control of one voltage, often called the signal voltage, by another

voltage, the **control voltage**. If the control voltage frequency is within the range of human hearing the signal can function both as a control voltage and as an audible sound; this dual role for signals and the resulting relationship between image and sound is a technique used frequently in electronic imaging. By use of control voltages the problem of continuously varying changes is overcome; one can move between discrete values without having to proceed through intervening values.

Control voltages can be periodic or non-periodic waveforms. Because they are signals, control voltages themselves can be processed by techniques such as mixing or filtering or can be amplitude or frequency modulated before they are used as control signals. Control voltage signals can exert influences on audio signals, video signals or other control signals. They can be generated by voltage control modules, audio synthesis equipment, or computers.

**SYNC:** In video, the image is actually an electronic signal. This video signal has two basic parts: The section containing picture information, and the section containing sync information. Synchronization is derived from the Greek *syn* and *chronos*—to be together in time; the term implies that several processes are made to occur together in time at the same rate so that they are concurrent. For a coherent picture to be formed which is easily readable to the eye and brain, the scanning motions of both the image or signal generating device, for example a camera, and the image or signal display device, the monitor, must proceed in an orderly and repeatable manner. The scanning processes in both camera and monitor must begin and end at precisely the same time. The camera and monitor must be synchronized. As the camera begins scanning the objects in front of it, the monitor begins to scan the line which the camera is scanning. As the camera ends the scan line, the monitor must also end that line. When the camera reaches the bottom of the field, the monitor must be exactly in step. Without this synchronization, the camera image and the monitor image will have no relationship to each other. **Horizontal sync** maintains the horizontal lines in step; without horizontal sync the picture will break up into diagonal lines. Horizontal sync tells the camera and monitor when each horizontal line

begins and ends. **Vertical sync** also keeps the picture stable; without this, the image will roll. Vertical sync tells the camera and monitor when each field begins and ends. Both together are essential to a stable rectangular shape. Sync then can be conceived of as an electronic grid which provides horizontal and vertical orientation to the image.

Each visible line forming the raster is drawn from left to right across the CRT. Before beginning the next line, the beam must return to the left, and this return must be invisible. During this horizontal retrace period, the beam is blanked out; this process and the time interval necessary to perform this function are called **horizontal blanking**. Horizontal blanking is a part of synchronization. At the end of each field the beam must return from the bottom to the top of the CRT before beginning to scan the next field. Again, this vertical retrace is not seen. This process and the interval are referred to as **vertical blanking**. Vertical blanking is also a part of synchronization.

Each of these blanking intervals includes information necessary to maintain proper timing relationships between camera and monitor so each begins scanning line and field at the same moment. The information which is contained in the blanking intervals is not picture information. The blanking intervals contain the timing signals which are called sync pulses. These sync pulses keep the images stable and accurate in terms of color.

Sync thus indicates a synchronization process. A number of sync pulses are required by an electronic image processing system. Normally these sync pulses are provided by a sync generator, a separate device external to the system which provides the same timing signals to each of the discrete devices within the system which need sync to operate. The single external sync generator provides identical sync signals to all of the cameras within the system.

One complete horizontal line includes both the visible picture information and also horizontal blanking. Within the period of horizontal blanking the horizontal sync pulse occurs. The horizontal sync pulses occur on each line during the horizontal blanking interval and before the picture information of that line is displayed. After the beam has scanned one line, the beam is blanked out in preparation for

the next scan; it is during this interval that the horizontal sync pulses are inserted. They insure that the line just scanned by the camera can be accurately reproduced by the monitor and tell the monitor when each line is to be scanned. One complete horizontal line is scanned in 63.5 microseconds, or .0000635 seconds. The visible picture portion of this line takes approximately 52.7 microseconds. The remaining time, 10.8 microseconds, is the horizontal blanking period. The blanking period consists of the front porch section which is approximately 1.27 microseconds, the horizontal sync pulse and the back porch section each of which are approximately 4.76 microseconds. The back porch is approximately 3.5 times as long as the front porch.

The vertical sync pulses occur within the blanking interval at the beginning of each field. The first 21 lines of each field consist only of timing information. They do not contain any picture information. They are collectively known as vertical blanking. The following 241.5 lines of the CRT are scanned, and then the beam has traced all of the picture lines. The period of time it takes for the beam to return to the top after each field is scanned is called vertical blanking, approximately 1330 microseconds long, much longer than horizontal blanking.

The first series of pulses to occur during the blanking interval are six equalization pulses. These are followed by the vertical sync pulse serrations, which are followed by another series of six equalization pulses. The duration of one set of pulses or three horizontal lines, is abbreviated 3H. The frequency of the equalization pulses is twice the horizontal frequency. These equalization pulses help to maintain the interlace between fields and also help to keep the oscillators which control the horizontal scanning in step during the time in which no lines are being scanned. The equalization pulses insure that the vertical deflection occurs at the same time as vertical sync. They also keep the horizontal deflection in step.

The vertical sync controls the field-by-field scanning process performed by the electron beam and also maintains the horizontal oscillator in step. The function of the vertical sync pulses is to indicate to the monitor when each field has ended so that the camera and monitor begin and end each field in

direct relationship to each other. The vertical serration pulses help maintain proper horizontal frequency during the vertical interval. The frequency of the serration pulses is twice the horizontal frequency. The horizontal sync pulses which conclude the vertical blanking interval also help to keep the horizontal oscillator in step during retrace.

In order to achieve interlaced scanning, each field contains a half line of picture information. The line preceding the vertical interval of the odd field is one complete picture line. This line is the last line scanned in the even field. The vertical interval, occupying 21 H lines, then follows. The first picture line of the odd field which follows the vertical interval is one full picture line. 241.5 picture lines follow. The 21 lines of the vertical interval and the 241.5 lines of the picture information total the 262.5 lines needed for one field. The last 1/2 picture line of the odd field then immediately precedes the vertical interval for the even field.

The odd field, as noted, is preceded by one complete picture line, the last in the even field. The vertical interval for the odd field begins with six equalization pulses occupying 3H. Six serration pulses follow, also occupying 3H lines. After the next six equalization pulses, the horizontal sync pulses occur. The first of these occupies 1/2 line. It is here, in part that the off-set relationship occurs which provides for interlaced scanning. Eight to twelve horizontal sync pulses without picture information conclude the vertical interval. Following the 21st line of the vertical interval is the first picture line of the odd field, a complete horizontal line. The odd field scans 241 complete horizontal picture lines and ends with 1/2 picture lines.

The vertical blanking period under broadcast conditions contains two additional signals which are used for reference and testing. The first, called the **Vertical Interval Reference** or **VIR** signal, is added to line 19 of both fields to maintain the quality of the color transmitted. Certain color receivers are now made which use this signal to automatically adjust hue or color and saturation. The second signal, called the **Vertical Interval Test**, or **VIT** signal, is used as a test signal to evaluate the performance of equipment and appears on lines 17 and 18. Other information can be coded into the vertical blanking interval, including program sub-

titles for hearing impaired individuals. The captions, provided in 1980 by several of the networks and PBS, appear on the screen as text when used with user-purchased decoders. Other systems can provide data such as weather, sports and news reports.

Sync and drive pulses are the timing pulses which keep one or several cameras in step with each other and with the videotape recorder or monitor. In a single camera system, sync can be obtained from the internal sync generator built into the camera. The video and sync information together are then sent to the deck or the monitor. In a multiple camera system, the internal sync generator in each of the cameras cannot be used to send timing information to the rest of the system. All cameras must receive the same sync signals from a common source at the same time, from a sync generator external to all of the cameras. Video or picture signals from all the cameras are then mixed in the processing system and combined with sync information. This single composite signal, containing both picture and sync information, is sent to the deck to be recorded.

A black and white sync generator usually supplies horizontal and vertical drive pulses, composite blanking which includes both horizontal and vertical blanking, and composite sync which also includes horizontal and vertical components. The function of the sync pulses is to indicate to the camera or monitor when one line, in the case of horizontal sync, or one field in the case of vertical sync, will end and the next begin. The blanking pulses make sure that the retraces, both horizontal and vertical, are not visible. Drive pulses control the timing of the beam's scan.

The color sync generator supplies horizontal and vertical drive, composite sync and composite blanking and two additional signals variously called **burst** or **burst flag** and **subcarrier** or **3.58 MHz**. Color signals must carry all color information, including the hue, brightness and saturation of the colors, by the use of three primary colors: red, green, and blue. In addition, their structure must be such that they are compatible with black and white systems. A color signal must play on a black and white television with no interference. Color signals must therefore contain both **luminance** and **chrominance** information. Luminance conveys the variations of

light intensity and is the part of the signal used by the black and white monitor. Chrominance conveys variations of hue, saturation, and brightness.

The subcarrier signal, with a frequency of approximately 3.58 MHz, carries information about color value. This frequency is produced by an oscillator in the sync generator, and is modulated or changed by the color information coming from the color camera to the colorizer in the image processing system. The ways in which the subcarrier is changed convey information about the color, its saturation and hue. For example, changes in the phase of the chrominance signal indicate changes in hue.

In order that changes in phase, for example, and the resulting changes in hue can be identified, a reference signal is required. The burst signal supplies 8 to 10 cycles of the 3.58 MHz subcarrier frequency without any color information. This serves as a reference point to establish the phase relationship of the subcarrier signal before it is modulated and starts to carry color information. The burst signal is located on the back porch of each horizontal blanking pulse. It is not present after the equalization or vertical pulses of the vertical interval. The average voltage of the color burst signal is equal to the voltage of the sync signal. Burst then helps to synchronize color.

The horizontal drive signal occurs at the rate of 15,750 Hz. Its duration is 1/10th of the time it takes from the beginning of one horizontal line to the beginning of the next, or about 63.6 microseconds. Vertical drive occurs at the rate of 60 Hz and lasts for about 666 microseconds. Both pulses are sent to the cameras to control horizontal and vertical deflection circuitry, that which dictates the scanning processes.

Horizontal and vertical blanking pulses are pulses which make invisible the retrace lines which occur as a line or field is ended and the beam returns to begin the next trace. Vertical blanking lasts about 1330 microseconds and horizontal blanking about 1 microseconds. Composite blanking with the addition of the video signal is sent to the monitor to blank out the vertical and horizontal retraces. The camera usually is not supplied with vertical and horizontal blanking because the horizontal and vertical drive pulses can accomplish the same function. It is during the blanking intervals that horizontal and

vertical sync occur. Horizontal blanking and horizontal drive control the direction and speed of each of the beam's horizontal traces and retraces. Vertical blanking and vertical drive control the change from one field to the next.

The sync signals tell the camera or monitor when the scan is to change. Horizontal sync controls the beginning and end of each horizontal line. Vertical sync controls the beginning and end of each field. It assists in keeping the monitor in step or in sync with the camera. In a multiple camera system it also keeps all cameras synchronized with each other. Some cameras use sync rather than drive signals to produce the deflection signals which control the beam's scanning processes.

**Line frequency**, or 15,750 Hz, is produced in the camera and monitor by crystals which oscillate or vibrate naturally at the speed of 31,500 Hz. This rate is then divided in half electronically to produce the required 15,750 Hz frequency.

The **field frequency** of 60 Hz can be derived by dividing the line frequency by the number of lines (525). These pulses can then be sent to the horizontal and vertical deflection circuits of camera and monitor to insure proper scanning.

**Line and field time base stability** refer to the precision at which the line and field frequencies operate. Exact operation is essential to the operation of the system as a whole and compatibility between output signals from different systems. The stability of the time base found in small-format recording can be corrected through the use of a time base corrector.

If the signal sent from the camera to the monitor includes picture information, horizontal sync, horizontal blanking, vertical sync, and vertical blanking, then the signal is called a composite black and white video signal. If the sync information is not included in the signal sent from the camera, this signal is called a non-composite video signal.

In a single camera system, the sync generator inside the camera may be used to generate the necessary sync information for recording and display. In this instance, the camera is usually referred to as being on internal sync, and the composite video signal is sent to the recorder or monitor. A single camera system may also be used with a sync generator which is external to the camera. In this



case, the external sync generator generates the sync information which is then sent to the camera. The camera in this case is on external sync. Some cameras can operate on either internal or external sync. There is a switch on the camera for selecting the sync option. Many cameras only operate on internal sync. These cameras cannot be used in multiple camera systems. Whether internally or externally locked, signals are produced which drive the deflection systems of the camera and insert the waveform onto the video out signal which causes the monitor to be in sync with the camera.

In a multiple camera system, such as an image processing system, the sync information for all cameras must come from one common source. In a multiple camera system, each of the cameras is sending picture information which will eventually be combined and treated by a variety of image processing devices. Techniques such as mixing, switching, or keying can be employed. None of the cameras in the system is generating its own sync information. A common sync source is sending identical sync information to each of the cameras in the system. The camera then sends back to the system a composite video signal containing both picture and sync. If each of the cameras in the system were to generate its own sync, there would be no consistent timing information throughout the system. It would then be impossible to achieve a stable image. In an image processing system the sync generator which sends sync to all of the cameras is usually external to each of the other components in the system. One common source sends the same information to each of the cameras.

The monitor or deck receives a composite video signal from the system which includes: picture information, horizontal and vertical blanking, horizontal and vertical drive, and horizontal and vertical sync as well as the signals needed for color. The blanking, drive and sync information are used to control the deflection of the scanning beam, so that the image displayed is a stable and faithful representation of the camera images.

The sync generator then serves as a master clock which establishes the time frames for the signals which, when decoded, produce images. The sync generator insures that the scan and retrace processes for both horizontal and vertical in both cam-

era and monitor occur at the same intervals with respect to video. The sync generator also provides blanking signals, both horizontal and vertical, which are added to the video waveforms. If the sync generator also supplies timing signals to drive the deflection systems of camera and monitor which then maintains the phase relationships between horizontal and vertical scanning, the 2:1 interlaced scanning is achieved. If 2:1 interlaced scanning is not present, the sync is termed "industrial" or random.

If the horizontal and vertical signals are not locked together in phase but are derived independently, then random interlace scanning results. In this type of scanning, the horizontal lines in each field are not in any fixed position and are not evenly spaced. Occasionally because of this lack of even horizontal positioning, horizontal lines may be traced on top of each other. This results in the loss of picture information contained in the superimposed lines and a degradation of the picture. This is called line pairing.

During the vertical sync period, it is necessary that horizontal information be supplied or the horizontal oscillator in the monitor may drift. The frequency corrections to that oscillator which are then needed following the vertical sync period may cause flagging at the top of the image. Flagging appears as a bend toward the left or right in the first several lines of the image.

**VIDEO SYNTHESIZERS:** A video synthesizer or "image processor" is a general term referring to an assemblage of individual video signal sources and processors, all of which are integrated into a single system. There are three general categories of devices: 1) **signal sources**—devices which output a signal used in the system to generate an image, a control signal or a sync signal. 2) **processors**—devices which perform some operation upon the signals, such as gain or phase changes, and are often used to mix inputs and put out combined or processed signals. 3) **controllers**—devices which generate signals which are themselves inputs to processing devices to control an aspect of the image. These devices can be analog or digital in nature.

A video source is any device which internally generates a signal that can be displayed, and includes cameras, decks, character generator or os-

cillator. A processor is a device which either changes the parameter of the incoming signal (e.g. gain, polarity, waveshape) or combines two or more signals and presents them to the output (e.g. mixing, switching, wiping). Video processors include keyers, VCAs, mixers, colorizers, sequencers, SEGs and frame buffers. These terms are not absolute but have meaning relative to one another. A signal can be routed through processors in a linear order.

Signals have direction: that is, they are originated, are passed through devices and eventually wind up at a device which transduces, or changes, the signal into a form of information that is directly meaningful to our senses. In the case of video, the electrical signal is changed into information by the video monitor which our eyes understand as light and ultimately pictures. The video image itself does not travel through the machine, rather it is an electronic signal which represents the image that travels. This signal originates in a video camera or some other type of signal generator such as an oscillator in an analog synthesizer.

The three main types of image processing signals are: 1) video signals—those which contain the complete information necessary for a monitor to construct an image 2) sync signals—those containing structural, rather than picture, information, which when combined with picture information allows it to be stable and rectangular. 3) control signals—those which contain information for the control of processes.

An image processing system is then a collection of devices the structure of which includes: 1) sync, 2) routing, 3) an output amplifier, 4) a method of monitoring, 5) a method of control.

**Termination:** A commonly used video connection scheme is the looped-through input, sometimes called a bridged input. This set-up facilitates ease in formulating multiple connections while maintaining the ability to “terminate” the video signal. Termination is required at the farthest input. This is usually done by connecting a terminator to the remaining bridged connector. Sometimes a switch is provided on a monitor input for termination, labelled “75 ohms” in one position and “high” in the other. The 75 ohm position is the terminating position.

**Genlock:** Sometimes it is desirable to take as an

input to the image processing system a video signal from a pre-recorded videotape. Since the sync from the source is controlled from the point of origin (the VTR) it is necessary to “lock” the system sync to the sync from the source. A genlock is required for this operation. Genlock is also used for cameras which are not externally syncable. This includes most consumer cameras. The output of the camera goes to the genlock input of the SEG and the system will lock to the internal sync of that camera. A VTR cannot be used as a direct source once the genlock is occupied by the camera.

Three devices are used to check the signal coming from the output amp: The **waveform monitor**, the **vectorscope**, and the **color or black and white monitors**. These are also used to compare the signal at different points in the path.

The waveform monitor does no processing of the video signal. It allows us to examine the quality of the video signal by giving us a graphic representation of the voltage of the video signal with respect to time. The waveform monitor is really a special purpose oscilloscope. Vertical distance on the waveform display represents voltage, while horizontal represents time. There is a choice of “strobe” times so that one field or line of the video signal can be observed.

Normally, the waveform monitor is set to display two horizontal periods, or two lines of video. What is seen is actually an overlay of many different lines. Within this, you can see the luminance and black level of the signal as well as the stability of the sync. Other settings show the vertical scan period and an enlarged view of color burst.

A vectorscope shows the color portion of the video signal. It uses the convention of a color wheel to represent the signal. Chroma, or saturation, is indicated by how far the signal extends from the center. It should not exceed the outer circumference of the circle of noise which may appear in the recorded signal a few generations later. The hues are marked at specific points initialed M (magenta), R (red), G (green), Y (yellow), B (blue), and C (cyan). The vectorscope has a phase adjustment which places burst at 180 degrees. At this setting when color bars are patched to its input, the signal's six points will correspond to the marks.

There are several types of color monitors. There

is also a bank of four black and white monitors, used as preview monitors. Their inputs are routed from four separate points on the matrix and are used to look at primary image sources, for example, cameras. They can also be used to look at the output of modules in various stages of a patch. They do not indicate the signal coming from the output amp.

Every module that you pass a color signal through will change the phase of that signal. Since the output amp is always the final destination, you can readjust the phase to compensate for hue changes.

When mixing a live camera or color genlock tape with the colorized image, consider the last module in the system where the two signals will be combined. Looking at the module's output through the output amp, adjust the phase control so that the "real" color is correct. Then adjust the hues of the colorized signal with the controls on the colorizer.

Some modules will generate noise at their outputs when a color signal is routed through their inputs. These include the clip inputs to keyers and the inputs to the frame buffer. The noise with the keyers may generate useful effects. Do not use a color signal as input to the buffer. A color kill is used with a separate input and output on the matrix. This strips the chroma and the original color signal still available from its point on the matrix. A monochromatic version to the signal is also available at the output of the matrix for routing into the buffer and key clips if desired.

A **sequencer** is a multi-input device which switches from one input to another automatically. The number of inputs and rates of switching vary with the device.

**Keying** is a process of graphically combining video signals. It originally was developed in the television industry for the purpose of electronically imitating a filmic technique known as matting. In this context, the most conventional use has been to take two camera images and juxtapose them in a way which creates the illusion of a single, continuous three-dimensional space. Thus keyers are often referred to in terms of placing one image "behind" an object in a second image or of "inserting" an image "into" an area of another image. Using a keyer, you can create a shape in a first image, by defining the gray values that comprise that shape, and then remove all portions of the image within the bound-

ary of that shape. Into that hole you can then insert the portions of a second image which spatially correspond as if the two images were to be superimposed. The development of a keyer as a three-input device, with voltage controllable parameters as well as its use in an image processing system necessitates a broader understanding of the functions of a keyer.

There are three channels in the luminance, or black and white, keyer: Two main channels, A and B, and a clip input. Each of the main channels is a VCA or voltage controlled amplifier, which sends the incoming signal to the same electronic switch. At any given moment, this switch chooses either signal A or B at its output. The rate of switching is fast, taking place several times within each horizontal line of each frame. The video signal that is going into the clip input controls this switch. A clip level determines a certain threshold point, and the clip input signal is compared to the threshold. It is the voltage levels of the signals that are being compared. When displayed on the raster, these voltage levels become the gray levels of the image. The comparison is being made at each point on each horizontal line. When the voltage of the clip input signal exceeds this threshold point, and the signal is therefore brighter than a predetermined gray level, channel A is presented at the output of the switch. When the voltage of the signal falls below the threshold, and is therefore darker than a certain gray level, channel B is seen. Moving the clip level control knob clockwise increases the threshold point. This allows more of B to be seen than A. Thus channels A and B will always be on opposite sides of the clip edge. A key reversal simply exchanges the positions of channel A and B relative to this threshold point.

The conventional use of a keyer as a matte device is a specific case in which one of the two signals going into the VCAs is also being used as an input to the clip channel. This technique is often referred to as **internal keying**. Some keyers are hardwired in a way which allows internal keying only. When a third signal, separate from either of the VCA input signals is patched to the clip input, this is called **external keying**.

**Split-screens** are a specific application of external keying. An externally-synced oscillator is used

as the clip input signal to switch between the two main channels. A continuous change in the threshold point, or clip level, from low voltage to high voltage, or vice versa, is often called a **wipe**.

A **colorizer** takes as its input a black and white video signal, then adds color in a fashion according to the type of colorizer. Usually a colorizer unit contains other video processing as well, such as negative video, keying, mixing.

*A chronology of the activities at the Experimental Television Center, Binghamton, New York, 1971-1978, founded by Ralph Hocking and currently under the direction of Ralph & Sherry Miller Hocking.*

### 1972

NYSCA funding to the Center for construction of Paik/Abe Video Synthesizer. One system was designed and built at the Center by Shuya Abe and Nam June Paik for eventual placement at the TV Lab at WNET-TV in 1972. This system was used while still at the Center to produce a portion of Paik's "The Selling of New York," included in the PBS series "Carousel," broadcast 1972 by WNET. A second system was built for the Artist in Residency program at the Center and used in '72 by artists such as Ernie Gehr, Hollis Frampton, Jackson MacLow and Nick Ray, and also included in an exhibition at the Everson Museum. A raster scan manipulation device was also constructed, the principles of which were defined by Paik's early TV experiments, such as Dancing Patterns.

### 1972 - 73

David Jones became technician at the Center. Artists participating in the Residency program included Taka Imura, Doris Chase, and Michael Butler. Workshops in imaging were held regularly at the Center, and also at Global Village and at York University in Toronto. Oscillators were designed for use as signal inputs to the synthesizer. Initial research into the Jones gray level keyer and production of a black and white keyer. Modification of an existing SEG for direct sync interface with the Paik/Abe with provision for external wipe signal input.

### 1974 - 75

Workshops and performances based on image processing were conducted at The Kitchen, Anthology Film Archives and the Contemporary Art Museum in Montreal. NYSCA supported a series of travelling performances by Walter Wright on the video synthesizer. Over ten organizations throughout New York State and Canada took part. The workshop program at the Center continued. NYSCA provided funding for the development of the Jones Colorizer, a four channel voltage controllable colorizer with gray level keyers. The oscillator bank was completed and installed. The SAID (Spatial and Intensity Digitizer) was developed by Dr. Don McArthur (April 1975) as an outgrowth of research on b/w time base correction. Work was begun by David Jones, Don McArthur and Walter Wright on a project to explore computer-based imaging, and the interface of a computer with a video processing system. Artists-in-Residence included Neil Zusman and Gary Hill.

### 1975 - 76

The Residency Program included artists Nam June Paik, Phil Jones of Ithaca Video Projects, Ken Marsh and Ken Jacobs. The NEA in 1975 provided support for initial research into the computer-video processing project, which was expanded by Jones, McArthur, Wright, and Brewster to incorporate parallel research efforts by Woody and Steina Vasulka, and Jeffrey Schier. The LSI-11 computer was chosen as the standard. Jones developed hard and soft-edged keyers and a sequential switcher, which along with the Jones Colorizer was incorporated into the processing system. A commercially available SEG was modified to incorporate these keyers. A 64-point push button switching matrix was designed and built. We began to write a manual, developed initially to be used as an operator's guide to 1/2" reel-to-reel equipment, portapaks, editing equipment, and the like. The concept was later broadened to include step-by-step construction information on a Paik Raster Control Unit. By 1985, the information was expanded to include systems structure and theory of electronic signals and processing techniques. These manuals have been distributed to many individuals and organizations over the years. Cloud Music by David Watts, David Behrman, and Bob Diamond was presented at ETC.

**1976 - 77**

Artists such as Barbara Buckner, Aldo Tambellini, Nam June Paik, and the ADA continued to participate in the Residency Program. The computer project continued. The exhibition series, Video by Videomakers, was begun, introducing to this region video works by Beryl Korot and Barbara Buckner. The computer was installed as part of the system and made available to artists; software research began. For the second year, we conducted a series of workshops in school districts throughout the region, in collaboration with Binghamton's major arts center, the Robertson Center.

**1977 - 78**

NYSCA funding helped support the development by Jones and Richard Brewster of the Analog Control Box allowing the production of electronic sounds and also signals which controlled parameters of the video signal. The computer project proceeded, assisted by Paul Davis, then director of the student computer lab at the School for Advanced Technology at SUNY-Binghamton. Artists-in-Residence included Shalom Gorewitz, Sara Hornbacher, Hank C. Linhart, and Hank Rudolph. We conduct workshops for the City of Binghamton, Headstart, Tri Cities, 4H Program, and Center for Media Studies.

**1978 TO PRESENT**

*Due to the historical nature of the exhibition, this listing only covers the early years. However, since 1978, the Center has continued their active programming based upon their mission as described.*

R&D Program Concepts:

1. Modification of existing equipment: to expand its capabilities in order to bring out all possible controls to the artist.
2. Design and construction of image-processing equipment: to expand the Center's system; to make equipment and/or information available to individual artists.
3. Development of print information and educational strategies to teach artists and others the principles of image processing; to encourage artists to approach video as a directly mediated art practice; to encourage artists to use tools themselves in art-making ; to encourage artists to build or purchase equipment for their personal studios.
4. Design considerations: Flexibility; low cost; ease of use; greatest number of possibilities for image and sound generation, manipulation and control.

# THE FORM AND SENSE OF VIDEO

artscanada, 1973

Robert Arn

How then, if formal characteristics are so important, are we to explain the assumption that television is like film? Or the almost total absence, after more than 20 years, of formal descriptions of the television process? The answers are mostly to be found in economic and social rather than artistic history and need not concern us here. The fact remains that to date, television both in production and viewing has been dominated by the conventions and assumptions of narrative film. It is criticized in terms of content of the crudest narrative or logical type. Which is odd, since very few who regard television in this limited way would chance interpreting film purely in terms of the narrative conventions of the novel.

From the first, film has been perceived practically, critically, and theoretically by those whose interest is primarily narrative or content-related, or by those who see its process as opening new forms of perception to the audience and thus new fields of expression to the artist. But of course film did not suffer from a flight of intellectuals at its birth. Born in the Constructivist period of technological optimism, it was immediately the focus of intellectual attention, while television even now faces a technological paranoia which has blocked serious conceptual study of its formal characteristics and has thus enforced an *artistic* triviality as profound as its *social* impact. However, even film criticism is shaky in some of its formal descriptions; some misconceptions about the filmic treatment of time will need to be righted before we can reach an adequate formal description of video (or television-as-an-art-form).

In 1924 film was new and fascinated with itself. Dziga Vertov, out with his camera end-

lessly walking, created *Man With a Movie Camera* and revealed the new possibilities open to man's cinextended perception. He called this mechanically extended perception "cine eye." Through his viewfinder Vertov saw space expand and contract and perspective shift with lens change. He found that time was under his control: crank the camera a little faster and it all slowed down. Film allowed man to experience what was hitherto beyond his perception – the malleability of space and time. However, others realized the corollary: to say that film extends perception is the same, in one sense, as saying that it distorts perception. Current followers of Vertov – say Jean-Luc Godard and Jim McBride – maintain a reflexive commentary in their films on the distortions of reality introduced by the filming process and our conditioned expectations of it. In fact, the illusion of reality is only achieved by relatively large distortions of actuality. Vertov tells us what now seems obvious – that the matter of film is the manipulation of time and space.

Intuitively, one might expect the manipulation of time to be the dominant formal characteristic of film – the illusion of movement after all is its primary difference from mere photography, and its primary use is in dramatic narrative which exists (barring several attempts at Aristotelian temporal unity such as Agnes Varda's *Cleo de 5 à 7*) by tricking the time sense. Intuition is a bad guide in this case, however, since such a system of temporal illusion is the basis of all narrative art whatever. Much more to the point is the question of how film *differs* from other forms in its use of time. Film's most characteristic means of temporal manipulation, parallel editing (The Maiden on the Railway

Track Rescue at Hand, phenomenon; or, Meanwhile Back at the Ranch) is not intrinsic to film at all but derived from the Dickensian novel by Griffith and developed by Eisenstein. It, like most other conventions of film editing, is necessary to all flexible narrative forms and is found equally in most. The most purely filmic distortion of time – slow or fast motion – is seldom used and relatively obtrusive, a “tic” of certain directors and penchant of the inexperienced.

The basic problem of film editing is easily stated – what shot to use next: Eisenstein saw that the decision was not a purely narrative or temporal one – that certain shots “worked” and some did not and that this was determined not by narrative sequence but by the graphic, compositional relationships of consecutive shots: editing sequence follows spatial relationship. Thus, though film does inevitably alter both time and space, it is primarily space art. A visual Marxist like Eisenstein cut for graphic conflict while most directors cut for graphic similarity to achieve smooth continuity. But composition rules the cut. Graphic space orders time.

Video art, in contrast to film (and also to television which is mostly a feeble narrative reflection of film), has suffered an arrested development. After 25 years of television, video art is entering its adolescence – still looking for its Dziga Vertov and vainly awaiting its Eisenstein. Like film in its earliest period, video is in a phase of self-examination or perhaps narcissism, absorbed in its own processes. The difficulty for the viewer is the fact that these processes – so superficially like those of film – are really quite different; and the responses we bring to film are inadequate and deceptive in relation to video. For example, for a long time I thought that the apparently clumsy editing of video pieces was a mere function of the mechanical difficulties of editing with existing equipment. The low-cost ½" and 1" tape recording equipment used by most artists does display its instability particularly in editing. But I now suspect that I have been applying expectations derived from film, where spatial graphic continuity determines editing, to video whose space/time structure makes such criteria meaningless. Classic editing technique is to be found among video artists. Andy Mann, for instance, produces tapes of almost

vintage Eisensteinian montage. Most video artists who create such work support themselves by producing documentary tapes for business and organizations who demand film-like products; and I suspect film conventions inevitably creep over into their other work. Now when I see video of traditional film editing style it seems slightly out of place. The critics' dilemma: how to avoid seeing “different” as “inferior.”

In film the impression of movement is derived from a succession of frozen moments. In contrast, the video image, even if each frame is examined, is all motion. Even a still video image is in motion – a single rapidly moving and constantly changing dot, one dot only, does all the work. The basic *illusion* of film is *motion*. The basic *illusion* of video is *stillness*. A detail of the video image may be located by pointing out where it is (as in film), but also by specifying its distance in time from any other point of the image. Any point on the image is both “where” and “when” or “wherewhen” from any other point. Video is quite literally a space/time machine. In this context the lack of the simple juxtaposition of shots characteristic of film editing is more comprehensible. Continuous motion or metamorphosis is the continuity line of most video art; an art of becoming rather than comparison, an art of time.

Before exploring in more detail the space/time nature of video and its implications in the work of video artists, some of the ways video resembles film in its processing of reality should be considered. Godard has said that film is the truth 24 times a second, which is to say that it is a lie – unless truth really happens at that frequency. Video, then, is a lie 30 frames per second, or rather 60 “fields” a second since each frame consists of two alternate fields of scan lines.\* The intermittent nature of both film and

\*The repetition rate of video is not determined just by the persistence of vision but also by the line frequency of the electrical power-lines. Hence in North America film on video runs six frames per second faster than in the theater – but in Europe it runs the same speed, since the power-line frequency of 50 cycles per second gives 25 frames per second, which is equal to the established European cine-camera speed.

video gives rise to the stagecoach wheel phenomenon, or "strobing." Combine two periodic motions and you get an apparent motion proportional to the difference in rates. We have accepted this distortion in relation to rotary motion, but cameramen are careful with panning and tilting rates across vertically or horizontally barred fields to avoid strobing effects that might destroy the *illusion of reality*.

In both film and video, achieving realistic color requires some distortion of actuality and here we find a phenomenon of art that would have delighted Yeats. Video has become so widespread that public reality is modifying itself so as to look "real" on television. The announcer's blue shirt was just the beginning. The decor of almost all public events is now chosen with an eye to the sensitivity of cathode ray tubes. The line/scan of the video picture is also an important factor in this context. Horizontal stripes have almost disappeared from public life since they react with the scan lines or "raster" on television to produce a disturbing moiré. A reality which cannot be comfortably facsimiled on television tends to drop out of public life.

The nexus of image/reality is the catalyst of a whole branch of video art that might misleadingly be called documentary, but is, I suspect closer to some sort of reality repair. Because of its low cost and immediate playback capabilities, video is becoming a major tool in psychotherapy and social action. Trapped as we seem to be in the cliché of alienation, we seek corroboration of our existence, and video is on its way to being a mirror for masses. The displacement of reality into the conventions of representation leads us to paraphrase Descartes – I appear on the screen, therefore I am. The key to therapeutic and activist use of video is found in the ambiguity of the word "image". Therapists talk of the difficulty of their patients in generating a body image; activists have found that politics is the art of the body politic image. Glancing through the National Film Board's *Challenge for Change* newsletter you catch a double refrain. People become real to bureaucrats only when they can document themselves within the conventions of television reality. And, even more basically, people only take their

own problems seriously and actively after they have been assured of their own reality by seeing themselves on television. Such image/reality inversions are not unique to video. What writer has not felt his self-image enhanced by seeing his work in print?

The ability of video to overwhelm our other reality indices is demonstrated by experiments that require subjects to perform simple tactile tasks while watching a slightly delayed recorded image of the action. Total confusion is the usual result. Even when one can feel an object, the image of the object is convincing enough to make us doubt our tactile sense. In the wider context of social response, few people who have seen a studio television production with live audience have failed to notice the audience preference for watching the action on the studio monitors even though the original is immediately before them. Two notable pieces recently shown in Toronto demonstrate video artists' concern with the power of their medium to dominate reality; both share a major metaphor indicating a basic distrust of such domination. Elsa Tambellini's piece *Cats*, shown at the *international festival of women and film* portrays caged tigers pacing nervously behind 300 bars. Live performers shooting each other with closed circuit cameras and finally stringing rope bars between the audience and its own picture on monitors, imprison first actors then audience in the medium [see p 38]. Juan Downey's piece at the Electric Gallery traces the image of imprisonment, or reality as medium, to its source in Plato's *Myth of the Cave*. The image is somehow more actual than the action it emulates. Is it any wonder that psychiatry and politics talk so much of image: Pygmalion and Dorian Grey admonish from the mythic wings.

However, I doubt that we should regard confusion of image and reality as pathological. That confusion surrounds one of the most paradoxical and contentious issues of art. What is real in art? In film, graininess and greytone degradation – the side effects of low lighting and forced processing of newsreel footage – became conventions of a school of realism, the stamp of *vérité* on any film image. It is difficult to know to what extent Cinema *Vérité* looks like newsreel footage because of similar technical con-



straints, and to what extent it *tries* to produce a grainy and degraded image in the knowledge that the audience associates such an image with recordings of real events. In my experience the two are inextricably tangled. Clearly the convention is totally conscious in Godard's *Le Petit Soldat*, or *Les Carabiniers*, films which dwell on our tendency to confuse conventional representations with the "real thing". The conquering heroes of *Les Carabiniers* return with postcards of conquered wonders as booty. They feel they have plundered the things themselves. The newsreel quality surface of the film presents us with the same dilemma as the heroes – is newsreel really real?

Manipulation of the conventions of representation has by now become almost a cliché – the bread and circuses of intellectuals. Nevertheless, the relation of art, conventional representation, and reality is perhaps the basic theoretical issue of modern art and has been so since the late nineteenth century. Does art imitate reality? Or does it create our very conception of the ultimately unknowable "out-there?" The issue is not substantially different in poetry, fiction, graphic art, film, or video. Video just accelerates this eternal dialectic of art. So Yeats argues:

That girls at puberty might find  
That first Adam in their thought  
Shut the door of the Popes chapel,  
Keep those children out.  
There on that scaffolding reclines  
Michael Angelo  
With no more sound than the mice make  
His hand moves to and fro  
Like a long legged fly upon the stream  
His mind moves upon silence.

He refers of course to Michelangelo's masterpiece of God creating Adam – *The Touch*. Yeats describes Michelangelo's painting hand in relation to the picture as the same as the relation of God's hand to Adam *in* the picture. Who then is the Prime Mover? Who created Adam? And God? Substitute Chic Young for Michelangelo and a half-tone screen for the brush, and Yeats gives birth to Andy Warhol.

Yeats never guessed that crass conventional forms of representing reality would be widespread or powerful enough to create "reality." But further speculation on epistemological problems common to all arts will not bring us closer to a description of those formal processes and possibilities that are unique to video – and just such a description is necessary before we can understand the field of intent and judge the execution of a piece of video art.

It is difficult fully to comprehend that calling video an art of time is not a metaphorical statement but a literal description of the process of generating the video image, any video image. As I mentioned before, the image of video is an illusion; there is only one rapidly moving dot of varying intensity on the screen. In an ordinary television picture the dot scans regularly whether an image is present or not, generating the set of 525 lines called a raster. To produce an image, one introduces a patterned modulation of the dot's intensity as it races across the screen. The varying intensity of the beam is perceived as a range of grey tones from white to black. The critical point here is that the video image is sensitive. It is not fixed but responsive to outside control and alteration at any point in its scan. Thus the essential nature of the video artist is quite different from that of the film artist who seizes discrete frozen images. The video artist controls or intervenes strategically in an ongoing process. Clearly, the aesthetic and critical implications of this distinction, in relation to the typical concerns of most video artists, are sweeping.

Perhaps the simplest and most obvious concern of video art is with the nature of "process" itself, and with the paradoxes and illusions of time on which the concept rests. Consider, for example, the multiple tape-delay environments which have fascinated so many video artists. The simplest form of tape-delay is familiar to broadcast television viewers; the instant replay has transformed sports viewing. But few sports enthusiasts realize how an extension of this technique can break down the conventions of time, and cause and effect.\* Video, unlike film, requires no processing; it may record a live event on one machine and play it back simultaneously with varying delays by passing the tape through playback decks at various distances

from the recording machine. Moreover, while the tape by its nature must pass in progression from one machine to the next, the displays from these playbacks may be arranged so that the viewer experiences them out of their normal temporal order. Most tape-delay pieces multiply these time-windows and often scramble their sequence so as to attack our conventional sense of time. It requires very little in these environments for the viewer-actor to lose track of the present – even though the screens may be portraying his own actions. Present, past and future become arbitrary, cause and effect absurd. The environmental pieces of Woody and Steina Vasulka pursue the paradoxes of reality a step further. Again, multiple presentation of image is used, but now the same image is displayed moving uniformly across the screen so that it appears to enter at one side and leave the other. Strings of screens placed next to each other give the impression at first that the image is moving from one screen to the next, but soon the images seem to stand still leaving the viewer with the impression that the whole environment is accelerating across the field of the image like the sensation of a train pulling out of a station: a concrete representation of the paradoxes of Einsteinian physics – relativity art. (Michael Hayden has remarked to me that he responded to neon signs and theater marquees in this way and I suspect we can anticipate relativity effects in three dimensions in his projected *Waves* video/computer project.)

Obviously in all such pieces the viewpoint and reactions of the viewer are an essential part of the work itself – these trees make no sound as they fall in an empty gallery. An interlocked loop tends to form of the video process and the

\*A length of film or tape represents a temporal separation of recorded events. That is, since videotape moves through the playback deck at approximately 7½ inches per second and 16 mm film through the projector at 40/24 feet per second, an event separated in time from another by one second is separated in distance by 7½ inches or 40/24 feet respectively. If we use several playbacks, displayed continuously and simultaneously, of the same tape or film, the distance between the machines will determine the temporal separation between the images. Any image appearing on one display will eventually appear on the next; the intervening time being determined by the distance that point on the tape or film has to travel to the next deck or projector. Film, however, cannot be recorded and played back simultaneously. It must be sent away for processing.

viewer's physiological process, and hence a different viewing style is required. The viewer must become part of the process of what he views, and this requires a much longer attention span than the usual scan of graphic art, or the fitful attention of narrative film. Physiological process video operates on a longer time scheme than most other experimental forms and seems merely boring if not pursued to the point of object/observer fusion. (Luckily for artists studying physiological process, videotape is cheap – their work would be prohibitively expensive, even if possible, in film format.) Anyone experimenting with video in any form is likely to chance on physiological interaction patterns incidentally. I have noticed that vivid color hallucinations may be produced by pulsing different parts of a video image at different rates. Many people will see such a black and white picture in vivid (if unpredictable) color. Interestingly, there seems to be some positive correlation between intensity of color hallucination and the incidence of night blindness. Sadly, I don't hallucinate colors at all.

### Feedback

In imitation of physiological systems, an image that is responsive to control can become reflexive – self-controlling or regulative. This possibility gives rise to perhaps the purest line of video art: feedback patterning. "Feedback" in this usage is a technical term, designating the procedure of connecting camera and display-monitor in a loop, the camera photographing the display and feeding the result back into the same display. If, for example, a camera is photographing its monitor and projecting this image via its monitor, and the camera is then tilted, the monitor will be receiving a tilted image of itself – but this new image will contain the upright image of the monitor that was already on the screen before tilting the camera: there is no hiatus. The resulting image thus appears as a kind of superimposition; and with every subsequent alteration of the system the image will accumulate, generating an echo-corridor pattern which rapidly transforms itself into the mandala-like imagery typical of much feedback work. It is through step-by-step control of this cumulative property of the feedback system that feed-

back images are constructed. Images may be injected into the loop from other cameras or tape machines, or by placing objects between the camera and the screen; but even without external image intervention the system is itself a source of almost infinitely varying patterns, merely echoing the shape of the screen and the texture of the scan raster.

### Synthesis

In feedback, we reach the limit of talking about the video image as image. A feedback image is not a picture of anything finally; it is a balance of purely electronic forces below the threshold of perception. It is our entrance into that very specialized branch of video called image synthesis, in which the images are not records but creations achieved by manipulating the basic electronic forces at work in video cameras and displays. The term "synthesis" is familiar in the context of electronic music and the Moog synthesizer – or even in relation to chemistry or physics. Before a pure synthesis of anything is possible we must have a set of *basic* forms, forces, or building blocks from which to start. We do not synthesize a house from walls and roof but from board, brick and nails. Only when such basic units are established by analysis can we decide on a system of inter-relation which will lead us to the desired final product. If you don't analyse to small enough basic units you limit the variety of end products – witness the prefab house.

In electronic media the basic units are not tangible shapes or forms but forces – electrical energy: complex patterns of energy are built by inter-relating simple ones just as in more concrete forms of synthesis. In this context, however, the methods of inter-relating energy forms are of greater and more critical interest because they bear directly on the fundamental concepts of all art – analogy and metaphor. To control one thing with another is the simplest case of what we call analogy; a successful analogue relationship may result in a fusion which we could call a metaphor. To create complex patterns of energy one simply uses one aspect of

one simple form to control or alter an aspect of another simple form. Very complex patterns may be produced by elaborating the stages of control and relationship. Anyone who has used a Spirograph knows how to operate an analogue computer.

A deepening fascination with the processes of analogy is easy to detect in the background of most video artists. Some, of course, came to video from film or the graphic arts, but the majority had some involvement in the lightshow movement of the 60s, and moved through an interest in electronic music before working in video. The drive of lightshows was fairly simple; a quest to give a visual impression of sound. The full significance of that drive, as an exploration of the central mystery of metaphor and symbol, and hence of art, has only become clear in artists' successive absorption in electronic music and video.

The lightshow is a single term analogy; image is controlled so as to be analogous to the music. Eisenstein grapples with this concept in his theorizing on the use of sound in film. He tends to reject simple, positive one-to-one correspondence as too mechanical and prefers a negative counterpoint relationship, not noticing that a negative relationship is equally an analogy as is a positive. It is not the valence of relationship that matters, but its complexity; most metaphors are interlocking analogue systems of great complexity. The search for methods and principles of relationship seems to have intuitively attracted artists to electronic music and the Moog synthesizer, which builds up complex sound patterns out of the inter-action of simple electronic waveforms; and then finally to video synthesis where both image and sound may be analysed according to basic waveforms which in interaction with one another may produce literally any sound/image. Study of artists concerned with the analogue process seems to have led an intuitive critic like Gene Youngblood to create what can be seen as an aesthetic of analogy: he calls most avant-garde video art "synaesthetic." Unfortunately, his aesthetic is partisan and value-based, and fails to reveal the connection between the arts of complex analogy and the more general process of metaphor at work in all art.

Video synthesis proceeds along two lines – direct synthesis, which creates patterns by direct manipulation of time without any external input; and indirect or image-buffered synthesis which modulates input from an external source. Synthesizers developed by Eric Segal and Steven Beck work on the direct system; machines developed by Nam June Paik, Steve Rutt and Bill Etra work on indirect principles. For direct synthesis, imagine the raster of scan lines of the video image as a time track. Switching the beam intensity in varying time intervals will result in basic geometric patterns on the screen. These simple patterns can be elaborated by feedback into ever more complex shapes. Steven Beck's synthesizer starts from the very simple basis of generating two vertical and two horizontal lines, the positions of which may be changed by changing the time constants which determine their positions; and simple logic circuits can cancel the lines, leaving only the dots where they cross. A combination of external control on line position (each line may be made to move in analogy to a separate outside control) and feeding the image back on itself results in both delicacy of control and amazing complexity.

The indirect method of synthesis stems from Nam June Paik's early experiments in magnetic distortion of the video image. Since the raster of scan lines of the video tubes is generated by magnetic deflection of a single beam of electrons, any outside magnetic field will distort the scan field and any image it carries. Paik started by using permanent magnets which introduced a stable distortion to all images displayed on the altered set, but finally tapped into the deflection coils of the set itself so that he could introduce special distortions by means of an external control system. Rutt and Etra's design extends Paik's design by incorporating a separate deflection amplifier designed to permit modulation by outside control signals rather than by tapping into the somewhat crude deflection circuitry of the display monitor. The Rutt/Etra design gives analogue control over size and shape of picture, tonal structure of image, and spatial distortion on three axes. Its capabilities outrun those of the very expensive and inflexible digital computer systems currently in use to pro-

duce graphics for broadcast television.

It is tempting to see the technical problems of video synthesis as essentially solved. Combinations of the different synthesizer types give analogue control access to almost all dimensional aspects of the video image. Work remains to be done on electronic color, switching, keying and special effects – some of which is going ahead in Canada in my laboratory at Brock University, St Catharines, Ontario.\* Still, when all the technical work is done one has merely established a certain possibility – the equivalent of a brush, a chisel, a musical instrument. It remains for artists to create human and significant metaphors with this analogue capability, and for critics to find descriptive terms that illumine their concerns.

\* Anyone wishing a copy of our first technical bulletin, a 30 minute videotape outlining the state of the art in helical scan video equipment, send ½" or 1" videotape plus \$5 dubbing fee (if no tape is available, send \$20) to: Video Support Project, 36 Decew Road, R.R. 1, St. Catharines, Ontario. (Specify English or French version.)



# SPACE-TIME DYNAMICS IN VIDEO FEEDBACK

Physica, 1984

James P. Crutchfield\*

Video feedback provides a readily available experimental system to study complex spatial and temporal dynamics. This article outlines the use and modeling of video feedback systems. It includes a discussion of video physics and proposes two models for video feedback dynamics based on a discrete-time iterated functional equation and on a reaction-diffusion partial differential equation. Color photographs illustrate results from actual video experiments. Digital computer simulations of the models reproduce the basic spatio-temporal dynamics found in the experiments.

## 1. In the beginning there was feedback

Video technology moves visual information from here to there, from camera to TV monitor. What happens, though, if a video camera looks at *its* monitor? The information no longer goes from here to there, but rather round and round the camera-monitor loop. That is video feedback. From this dynamical flow of information some truly startling and beautiful images emerge.

In a very real sense, a video feedback system is a space-time simulator. My intention here is to discuss just what is simulated and I will be implicitly arguing that video feedback is a space-time analog computer. To study the dynamics of this simulator is also to begin to understand a number of other problems in dynamical systems theory [1], iterative image processing [2], cellular automata, and biological morphogenesis, for example. Its ready availability, relative low cost, and fast space-time simulation, make video feedback an almost ideal test bed upon which to develop and extend our appreciation of spatial complexity and dynamical behavior.

Simulation machines have played a very im-

portant role in our current understanding of dynamical behavior [3]. For example, electronic analog computers in their heyday were used extensively to simulate complex behavior that could not be readily calculated by hand. They consist of function modules (integrators, adders, and multipliers) patched together to form electronic feedback networks. An analog computer is set up so that the voltages in different portions of its circuitry evolve *analogously* to real physical variables. With them one can study the response and dynamics of a system without actually building or, perhaps, destroying it. Electronic analog computers were the essential simulation machines, but they only allow for the simultaneous computation of a relatively few system variables. In contrast, video feedback processes *entire* images, and does so rapidly. This would require an analog computer of extremely large size. Video systems, however, are not as easily broken down into simple function modules. But it is clear they do simulate some sort of rich dynamical behavior. It now seems appropriate that video feedback take its proper place in the larger endeavor of understanding complex spatial and temporal dynamics.

Cellular automata are the simplest models available for this type of complexity. Their study, however, requires rapid simulation and the ability

\* Permanent address: Physics Department, University of California, Berkeley, California 94720, USA.

to alter their governing rules. Video feedback does, in fact, simulate some two-dimensional automata and rapidly, too. With a few additions to the basic system, it can easily simulate other rules. Thus video feedback has the potential to be a very fast and flexible two-dimensional automata simulator. The dynamics of cellular automata are governed by local rules, but video feedback also allows for the simulation of *nonlocal* automata. At the end, I will come back to these possibilities and describe how simulations of cellular automata, and their generalization to nonlinear lattice dynamical systems, can be implemented with video feedback.

This is largely an experimental report on the dynamics of a physical system, if you like, or a simulation machine, called video feedback. My intention is to make the reader aware of the fascinating behavior exhibited by this system. In order to present the results, however, section 2 includes the necessary background on the physics of video systems and a very straightforward description of how to start experimenting. An important theme here is that the dynamics can be described to a certain extent using dynamical systems theory. Section 3 develops those ideas and proposes both discrete and continuous models of video feedback dynamics. The experimental results, then, take the form in section 4 of an overview of a particular video feedback system's behavior and several snapshots from a video tape illustrate a little bit of the dynamical complexity.

## 2. Video hardware

In all feedback systems, video or other, some portion of the output signal is used as input. In the simplest video system feedback is accomplished optically by pointing the camera at the monitor, as shown in fig. 1. The camera converts the optical image on the monitor into an electronic signal that is then converted by the monitor into an image on its screen. This image is then electronically converted and again displayed on the monitor, and so

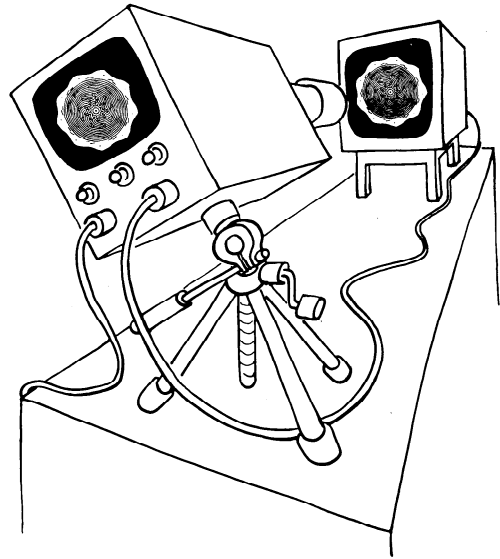

Fig. 1. Single video feedback. Information flows counterclockwise through the electronic and optical pathways.

on ad infinitum. The information thus flows in a single direction around the feedback loop. In fig. 1 the image information flows in a counterclockwise loop. This information is successively encoded electronically, then optically, as it circulates.

Each portion of the loop transforms the signal according to its characteristics. The camera, for example, breaks the continuous-time optical signal into a discrete set of *rasters* thirty times a second. (See fig. 2.) Within each raster it spatially dissects the incoming picture into a number of horizontal scan lines. It then superimposes synchronizing pulses to the electronic signal representing the intensity variation along each scan line. This composite signal drives the monitor's electron beam to trace out in synchrony the raster on its phosphor screen and so the image is reconstructed. The lens controls the amount of light, degree of spatial magnification, and focus, of the image presented to the camera.

Although there are many possible variations, in simple video feedback systems there are only a few easily manipulated controls. (See table I.)

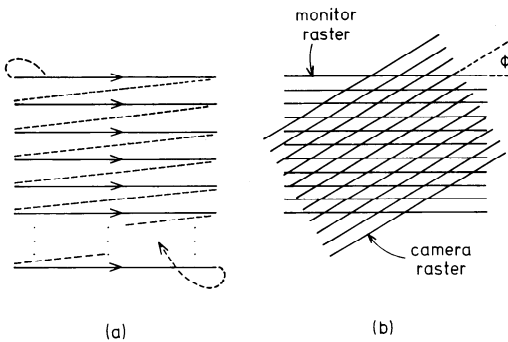

Fig. 2. Video raster with arrows indicating the direction of scanning. Solid lines correspond to when the electron beam is on; the dashed lines when the beam is off during the retrace time. (b) Since the raster defines the horizontal, in a feedback system the relative orientation as shown of the camera and monitor is an important control parameter.

The optical controls provide gross spatial transformations of the image seen by the camera. *Zoom*, available on most modern color cameras, conveniently allows for spatial magnification or demagnification. The same effect can be produced using a camera without a zoom lens by moving it closer to or further from the monitor. *Focus* con-

trols image sharpness by moving the focal plane in front or behind the camera tube's image target. The total amount of light admitted to the camera is set by the *f/stop* or iris control. When pointing the camera at the monitor the relative position, or *translation*, of the raster centers and the relative angle, or *rotation*, (fig. 2b) are important controls.

Electronic transformation of the signal occurs in both the camera and the monitor. The sensitivity of the camera's tube is adjusted by a *light level* control. Some cameras also provide for *luminance inversion* that inverts the intensity of the color signals. When switched on, this allows one, for example, to view a color negative print with the camera as it would appear in a positive print. The image intensity can be adjusted again on the monitor with the *brightness*. The *contrast* controls the dynamic range of the AC portion of the intensity signal. On color monitors the amount of color in the image is set by the *color* control and the relative proportion of the primary colors (red-green-blue) is governed by the *hue*.

While the effect of each individual adjustment can be simply explained, taken together they present a formidable number of control variables

Table I  
Typical control parameters on color video feedback

Name	Function
<i>Optical</i>	
zoom	spatial magnification
focus	image clarity
<i>f/stop</i>	attenuates incident light level
rotation	relative angle of monitor and camera rasters
translation	relative position of monitor and camera raster centers
<i>Electronic</i>	
Camera	
light level	adjust sensitivity of camera pickup tube
luminance inversion	inverts intensity signal for each color
Monitor	
brightness	varies overall intensity signal
contrast	amplifies dynamic range of intensity
color	attenuates color signals to black and white
hue	relative signal strength of colors



that can interact nontrivially. These problems will be considered in greater detail in the ensuing discussion of TV theory and possible mathematical models of feedback dynamics. This section now ends with a "cookbook" procedure for setting up a feedback system.

Although the detailed and quantitative dynamics will vary with the specific equipment used, my experience indicates that almost all servicable cameras and monitors will give some interesting behavior. This may require some patience as there are a number of controls to be properly set. But once "tuned up" a system will exhibit complex and striking imagery in a reasonably wide control range. For the movie [4] and pictures described later the camera used was a Sony Trinitron HVC-2200 and a Sony Trinitron TV/Monitor KV-1913\*.

A typical start-up procedure might be as follows:

1) Connect equipment as shown in fig. 1.

2) Place camera five to six feet from monitor. The distance will depend on the monitor screen size and is not that important if the camera has a zoom lens.

3) Point camera at some object other than the monitor. Adjust camera and monitor controls to give a good image on the monitor. Vary these controls to get a feeling for their effect on the image.

4) Now turn the camera to face the monitor.

5) Again adjust the camera controls, especially the zoom and focus, noting their effect. A warning is necessary at this point: it is not a good idea to let the camera see any steady very bright image for more than 10 to 20 seconds\*\*. Bright, dynamic moving images are generally OK.

6) Adjust camera on its tripod so that it can be tilted about its optical axis.

7) Point the camera again at the monitor, focus

on the monitor front, and zoom in enough so that the "first" image of the monitor front fills 90% of the screen.

8) Slowly tilt the camera trying to maintain the camera point at the screen's center. On almost all tripods this will take some fiddling and readjustment. Try zooming in at various rotation angles between 20 and 60 degrees.

Another important element in this is the ambient light level. Some behavior is quite sensitive to, or will not appear at all if, there is any external source of light. Although, a flashlight, candle, or a quick flip of the light switch, can be good light sources to get the system oscillating again if the screen goes dark.

With this short description and a modicum of patience the experimenter has a good chance of finding a wealth of complex and fascinating spatial and temporal dynamics.

### 3. Toward a qualitative dynamics

In the beginning, I argued that a video feedback system is a space-time simulator. But a simulator of what exactly? This section attempts to answer this question as concretely as possible at this time. A very useful tool in this is the mathematical theory of dynamical systems. It provides a consistent language for describing complex temporal behavior. Video feedback dynamics, though, is interesting not only for the time-dependent behavior but also for its complex spatial patterns. In the following section I will come back to the question of whether current dynamical systems theory is adequate for the rich spatio-temporal behavior found in video feedback.

This section introduces the qualitative language of dynamical systems [5], and then develops a set of discrete-time models for video feedback based on the physics of video systems. At the section's end I propose a continuum model akin to the reaction-diffusion equations used to model chemical dynamics and biological morphogenesis.

\* The cost for this space-time simulator is a little over \$1000, approximately a cheap home computer.

\*\* Some new cameras incorporate "burn proof" camera tubes. They are much less susceptible than earlier cameras to the image "burn" that can permanently damage the tubes. Caution should still be exercised. Excessively bright images will shorten tube life.

Dynamic, time-dependent behavior is best described in a *state space*. A particular configuration, or state, of a system corresponds to a point in this space. The system's temporal evolution then becomes the motion of an *orbit* or *trajectory* through a sequence of points in the state space. The *dynamic* is the collection of rules that specify the evolution from each point to the next in time. In many cases these rules can be simply summarized as transformations of the state space to itself by iterated mappings or by differential equations.

As will be seen shortly, video feedback is a *dissipative* dynamical system. This means that on the average "volumes" in the state space contract, or in physical terms, that energy flows through the system and is lost to microscopic degrees of freedom. This property limits the range of possible behavior. Starting from many different initial states, after a long time the system's evolution will occupy a relatively small region of the state space, this is the system's *attractor*\*. An attractor is *globally stable* in the sense that the system will return if perturbed off the attractor. Different initial conditions, even states very near each other, can end up on different attractors. The set of points, though, that go to a given attractor are in its *basin of attraction*. The picture for a particular dynamical system is that its state space is partitioned into one or many basins of attraction, perhaps intimately intertwined, each with its own attractor.

Very roughly there are three flavors of attractor. The simplest is the *fixed point* attractor. It is the analog to the physicist's notion of equilibrium: starting at various initial states a system asymptotically approaches the same single state. The next attractor in a hierarchy of complexity is the *limit cycle* or stable oscillation. In the state space this is a sequence of states that is visited periodically.

\* Unbounded or divergent behavior can be interpreted as an attractor at infinity.

\*\* For simplicity's sake, I have not included the predictable *torus* attractor. It is essentially the composition of periodic limit cycle attractors.

The behavior described by a fixed point or a limit cycle is predictable: knowledge of the system's state determines its future. The last type\*\* of attractor, that is in fact a very broad and rich class, gives rise to unpredictable behavior. These are the *chaotic attractors*. While globally stable, they contain local instabilities that amplify noise, for example. They also have extremely complex orbit structure composed of unstable periodic orbits and aperiodic orbits.

An important branch of dynamical systems theory concerns how one attractor changes to another, or disappears altogether, with the variation of some control parameter. The motivation for this line of inquiry is clearly to model experimentalists' control over their apparatus. A *bifurcation* occurs when an attractor changes qualitatively with the smooth variation of control parameter. Changing controls corresponds to moving along a sequence of different dynamical systems. In the space of *all* dynamical systems, the sequences appear as *arcs* punctuated by particular control settings at which bifurcations occur. It is now known that these punctuations can be quite complex: continuous arcs themselves or even Cantor sets or fractals. The physical interpretation of these possibilities is very complex sequences of bifurcations. Thus dynamical systems theory leads us to expect not only unpredictable behavior at fixed parameters, but complex changes between those chaotic attractors.

With modifications much of this qualitative picture can be carried over to the dynamics of video feedback. It is especially useful for describing the context in which the complex behavior arises. In the following I also will point out possible inadequacies of the naive application of dynamical systems.

A single state of a video feedback system corresponds to an entire image, on the monitor's screen, say. The state is specified not by a small set of numbers, but rather a function  $I(\vec{x})$ ; the intensity at points  $\vec{x}$  on the screen. The dynamics of video feedback transforms one image into another each raster time. The domain of the intensity function  $I(\vec{x})$  is the bounded plane, whereas the domain of

the dynamics is the space of functions or, simply, the space of images.

This picture can be conveniently summarized by introducing some notation. The monitor screen is the bounded plane  $\bar{R}^2 = [-1, 1] \times [-1, 1]$  where the coordinates of a point  $\bar{x}$  take values in the range  $[-1, 1]$ . With this convention the center of the screen is  $(0, 0)$ . For the incoherent light of video feedback, there is no phase information and so intensity is all that is significant. The appropriate mathematical description of an image's intensity distribution is the space of positive-valued functions. We will denote the space of all possible images by  $\mathcal{F}$ . The video feedback dynamic then is a transformation  $T$  that takes elements  $I$  in  $\mathcal{F}$  to other elements:  $T: \mathcal{F} \rightarrow \mathcal{F}: I \mapsto I'$ .

The task of modeling video feedback is now to write down the explicit form of  $T$  using our knowledge of video system physics. To simplify matters, I will first develop models for monochrome (black and white) video feedback. With

color systems the modeling is complicated by the existence of three color signals and the particular camera technology. Once the monochrome model is outlined, however, it is not difficult to make the step to color.

The construction of the monochrome model requires more detailed discussion of the electronic and optical transformations in the feedback loop. Fig. 3 presents the schematic upon which this model is based. With the physics of these transformations as discussed in the appendix, a relatively complete model can be constructed.

The appendix reviews the operation of the common *vidicon* camera tube, how it (i) stores and integrates images and (ii) introduces a diffusive coupling between picture elements. These attributes impose upper temporal and spatial frequency cutoffs, respectively. The focus turns out to be an easily manipulated control of the spatial diffusion rate. The monitor's phosphor screen also stores an image but for a time negligible compared to that

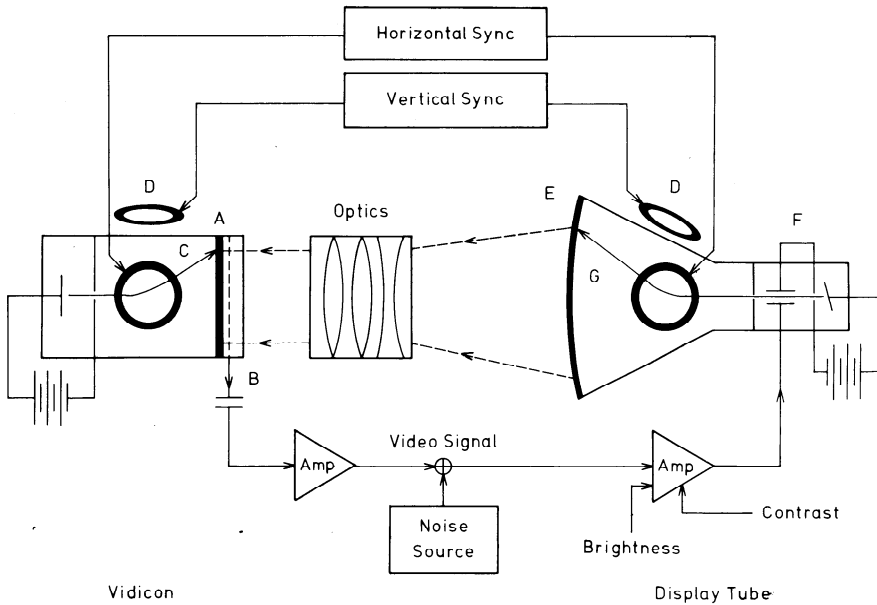

Fig. 3. Idealized monochrome video feedback. A: photoconductive image target; B: pickup for video signal; C: camera electron beam; D: scanning coils for electron beams; E: phosphor screen; F: beam intensity modulator; G: monitor electron beam.

of the vidicon. The appendix indicates various deviations from the ideal video feedback system of fig. 3.

With the physics and electronics of video systems in mind, the details of the transformation  $T$  can be elucidated for the monochrome model. The first and perhaps most significant assumption, is that  $T$  be taken as a discrete-time transformation of a spatially continuous function, the image  $I_n$ ,

$$I_{n+1} = T(I_n).$$

Employing a "bias intensity", the intensity at a point  $I_n(\vec{x})$  can be scaled to take values in the range  $[-1, 1]$ ;  $-1$  being black and  $1$  white. For comparison at the end of this section, I consider how a continuous time and space model can be applied to video feedback using reaction-diffusion equations.

The new image  $I_{n+1}$  consists of two parts: the first, the "old image" stored in the photoconductor, and the second, the "incoming image" from the monitor screen. This, and the process of successive feedback of images, can be expressed as an *iterated functional equation*. The first model of the dynamic  $T$  is the following

$$I_{n+1}(\vec{x}) = LI_n(\vec{x}) + sfI_n(bR\vec{x}), \quad (1)$$

where  $\vec{x}$  is a point in  $\bar{R}^2$ . The first term represents the old image whose intensity at the point  $\vec{x}$  has decayed by a factor of  $L$  each time step. Thus  $L$  is the intensity dissipation of the storage elements, including the monitor phosphor, but dominated by the photoconductor. The second term represents the incoming image that is possibly rotated by an angle  $\phi$  and spatially magnified by a factor  $b$ .  $R$  is then a simple rotation,

$$R = \begin{pmatrix} \cos(\phi) & \sin(\phi) \\ -\sin(\phi) & \cos(\phi) \end{pmatrix},$$

due to the relative raster orientations;  $b$  corresponds to the zoom control. If  $\vec{x}' = bR\vec{x}$  lies outside of  $\bar{R}^2$  then  $I_n(\vec{x}') = 0$ . The parameter  $f \in [0, 1]$

corresponds to the  $f$ /stop. For a system with luminance inversion black regions become white and vice versa. To take this into account the parameter  $s$  is set to  $-1$ , rather than its normal value of unity.

Spatial diffusion due to the photoconductor, but largely controlled by focus, contributes to the intensity at a point. It produces a spatial coupling to neighboring pixels that can be represented continuously by the following convolution integral:

$$\langle I_n(\vec{x}) \rangle_x = \int_{\bar{R}^2} d\vec{y} I_n(\vec{y}) \exp\left(\frac{-|\vec{y} - \vec{x}|^2}{2(\sigma_f + \sigma_v)^2}\right), \quad (2)$$

assuming a Gaussian shape for the diffusion profile. The denominator in the exponential controls the width of the smoothing with  $\sigma_f$  representing the focus control and  $\sigma_v$  the intrinsic smoothing in the vidicon.

A more complete model including the major features of video feedback systems is the following:

$$I_{n+1}(\vec{x}) = LI_n(\vec{x}) + L' \langle I_n(\vec{x}) \rangle_x + sfI_n(bR\vec{x}), \quad (3)$$

with the parameter  $L'$  setting the magnitude of the intensity signal contributed (or leaked) to that at  $\vec{x}$  during one raster time.

Furthermore, the first term in eq. (3) can be modified to include the temporal storage and integration of images and their successive decay. This can be effected by a weighted sum of past images,

$$\langle I_n(\vec{x}) \rangle_t = \sum_{i=0}^{\infty} I_{n-i}(\vec{x}) L^i,$$

where the decay parameter  $L$  is the same as above. This gives equations corresponding to the video feedback system as laid out in fig. 3,

$$I_{n+1}(\vec{x}) = L \langle I_n(\vec{x}) \rangle_t + L' \langle I_n(\vec{x}) \rangle_x + sfI_n(bR\vec{x}). \quad (4)$$

For a color system the scalar intensity becomes a vector of red, green, and blue intensities,  $\vec{I}(\vec{x}) = (R(\vec{x}), G(\vec{x}), B(\vec{x}))$ . There are also cou-

plings between the colors caused by a number of interactions and imperfections, such as

- 1) incorrect convergence of the monitor electron beams on the screen phosphor color dots;
- 2) non-ideal color filters and differential diffusion rates for the photoelectrons in the vidicon;
- 3) aberration in the optical system;
- 4) electronic cross-talk between the color signals in pickup, amplification, and reconstruction, of the image.

A model for color feedback can be developed as an extension of eq. (4) based on the evolution of a vector intensity  $\vec{I}$ ,

$$\vec{I}_{n+1}(\vec{x}) = \bar{L} \langle \vec{I}_n(\vec{x}) \rangle_t + \bar{L}' \langle \vec{I}_n(\vec{x}) \rangle_x + sf \vec{I}_n(bR\vec{x}), \quad (5)$$

where  $\bar{L}$  and  $\bar{L}'$  are matrices. Their diagonal elements control the color intensity decay, while their off-diagonal elements the coupling of the color signals. In a first order approximation, this model summarizes the various couplings only linearly although it is clear that nonlinear couplings could be added.

Along the same lines a continuous-time model can be developed that for many purposes is easier to study. This also allows for the comparison of video dynamics to other work on spatial complexity in biological and chemical systems. The type of model proposed here is generally called a reaction-diffusion partial differential equation. A.M. Turing introduced this kind of system in 1952 as a model for biological morphogenesis [6]. The general form of these equations is

$$\frac{d\vec{I}}{dt} = \vec{F}(\vec{I}) + DV^2\vec{I} \quad (6)$$

for the evolution of the "field"  $\vec{I} = (I_1, I_2, \dots, I_k)$  of concentration variables. The function  $\vec{F} = (F_1, F_2, \dots, F_k)$  represents the local "reaction" dynamics of these variables without diffusion.  $D$  is a matrix describing the spatial coupling and diffusion rate of the concentration variables. For linear  $\vec{F}$ , Turing showed that this system gives rise

to spatial patterns that can oscillate temporally. He also considered the addition of a noise term and its effect on the selection of spatial patterns.

These equations naturally take into account spatial diffusion with the Laplacian operator on the RHS of eq. (6). Furthermore, the continuous time derivative and the local reaction dynamics can be used to implement a temporal low pass filter. Thus, reaction-diffusion models can be constructed that satisfy the basic criteria already laid down for video feedback. Video feedback differs from Turing's reaction-diffusion models because of a nonlocal spatial coupling resulting from the spatial rotation and magnification. In direct analogy with the previous arguments, the proposed reaction-diffusion equation for color video feedback dynamics is

$$\frac{d\vec{I}(\vec{x})}{dt} = \bar{L}\vec{I}(\vec{x}) + sf\vec{I}(bR\vec{x}) + \sigma\nabla^2\vec{I}(\vec{x}), \quad (7)$$

where the parameters  $s, f, b, \bar{L}$ , and  $R$ , are as before, and  $\sigma$  is a matrix summarizing the spatial diffusion rate. The first term on the RHS of eq. (7) is the "old image", the next term is the nonlocal "incoming image", and the last is the diffusion coupling. For spatial structure and temporal behavior well below the spatial and temporal frequency cutoffs discussed above, this model should be valid. As will be seen in the next section, video feedback dynamics has very similar phenomenology to that of chemical and biological systems described by this type of model. The reaction-diffusion model provides a conceptual simplicity as well as simpler notation. In fact, video feedback can be used to experimentally study this widely used class of models for spatio-temporal complexity.

The previous iterated functional equation model eq. (4) can be derived from eq. (7) upon discretization. Eq. (7) is the differential form of eq. (4), an integro-functional difference equation. A digital computer simulation of this continuum model naturally involves spatial and temporal discretization. Thus, as far as verifying the models by

digital simulation, it is a moot point as to which is better, the iterated functional equation or reaction-diffusion model.

Having constructed these models, the burning question is whether their dynamics describe that actually found in real video feedback systems. For the very simplest behavior there is hope that the equations can be solved analytically. In general, though, simulating the models in a more controlled environment on a digital computer, for example, seems to be the only recourse [7]. After describing the dynamics typically observed in a real video feedback system in the next section, I will come back to the results of just such a digital simulation.

#### 4. Video software

The models and discussion of video physics in the last section may have given an impression of simplicity and straightforwardness in understanding video feedback dynamics. The intent in this section is to balance this with a little bit of the richness found in an actual color video system. An overview of the observed dynamics will be presented initially from a dynamical systems viewpoint. I will also address the appropriateness of

this framework for some of the more complex dynamics. Then a brief description of a movie on video feedback follows. Stills from the movie illustrate some of the curious features of video feedback dynamics. And finally, these "experimental" results will be compared to those from preliminary digital computer simulations.

Video feedback dynamics can be roughly categorized as in table II. For the simplest temporal behavior, descriptive terms from dynamical systems seem appropriate as in the first four behavior types. At first, let's ignore any possible spatial structure in the images. When a stable time-independent image is observed, it corresponds to a fixed point in the image space  $\mathcal{F}$ . Much of the behavior seen for wide ranges of control parameters falls into this category.

Thus on the large scale video systems are very stable, as they should be in order to operate properly in a wide range of environments. For extreme parameter settings, such as small rotation, low contrast, large demagnification, and so on, equilibrium images are typically observed. For example, when the zoom is much less than unity then one observes an infinite regression of successively smaller images of the monitor within the monitor within . . . . The image is similar to that

Table II  
Video feedback dynamics

Observed	Attractor in image space
equilibrium image	fixed point
temporally repeating images	limit cycle
temporally aperiodic images	chaotic attractor
random relaxation oscillation	limit cycle with noise-modulated stability
spatially decorrelated dynamics (e.g. dislocations)	quasi-attractor with local temporal dynamics: fixed point limit cycle chaotic attractor
spatially complex image	spatial attractor: fixed point limit cycle chaotic attractor (?)
spatially and temporally aperiodic	nontrivial combination of the above

seen when two mirrors face each other. With a bit of rotation the infinitely regressing image takes on an overall "logarithmic spiral" shape that winds into the origin.

When the parameters are set to moderate values, one of the first non-trivial dynamics to appear is a simple oscillation. This would be a limit cycle in image space: a sequence of dissimilar images that after some time repeats. Because entire images repeat, individual points on the screen exhibit periodic behavior. Consequently, the values of intensity at a point cycle repetitively.

At parameter values nearby often lie temporally aperiodic image sequences. Chaotic attractors in image space are most likely a good description of this behavior type in the simplest cases\*. When non-repeating images are reached from limit cycles with the change of a parameter, the bifurcation occurs in one of (at least) three ways:

1) Simple lengthening of the limit cycle period, until it is sufficiently long to be effectively aperiodic: for example, going from a limit cycle of 10 seconds to one of hours. New images are introduced, but are not sufficiently similar to be considered as close "recurrences".

2) The introduction of subharmonics at frequencies lower than that of the original limit cycle: these subharmonics are small modulations of the image's geometric structure. The overall image sequence remains the same, but differs in the modulated detail.

3) Suddenly at some critical parameter value, the limit cycle disappears and aperiodicity set in.

A very telling indication that complex behavior lies at nearby parameter settings comes from slightly perturbing the system. This can be done most conveniently by waving a finger between the monitor and camera. Once perturbed, the nearby complexity reveals itself by long and convoluted transients as the system settles down to its original

simple fixed point or limit cycle. The closer in parameters to aperiodic behavior, the longer the transients. The simple dynamics discussed so far are globally stable in just this sense of returning to the same image(s) when perturbed. Of course, one can perturb the system too much, knocking it into another basin of attraction and so losing the original behavior. It is a common experience, in fact, that hand-waving perturbations will leave the screen dark, with the system requiring a "positive" stimulus of light from some source to get back to its initial attractor.

At large zoom, or spatial magnification, the system noise is readily (and exponentially) amplified. This regime is dominated by bursts of light and color. Depending on the controls, the bursts can come at regular intervals or at random times. Also, the particular features of the bursts, such as color, intensity, or even the pattern, can be the same or apparently randomly selected. This behavior is quite reminiscent of a limit cycle with (noise) modulated stability [9].

The dynamics discussed so far is simple in the sense that its temporal features are the dominant aspect. No reference was made to spatial structure as the temporal dynamics was readily distinguished from it. A more precise way to make this distinction is in terms of whether the behavior at a suitably chosen point captures the dynamics [8]. Using intensity data from this point, if a simple attractor can be reconstructed, then the behavior is of a simple type that can be *decomposed* into temporal and spatial components. The last entries in table II are an attempt to indicate that there is much more than this simple decomposable dynamics. Indeed, the spatial structure and its interaction with the temporal dynamics are what makes video feedback different from other systems with complex dynamics, like chaotic nonlinear oscillators. But this difference presents various (intriguing) difficulties, especially because a dynamical system description does not exist for spatial complexity [10]. Nonetheless, a qualitative description is possible and, hopefully, will lead to the proper theoretical understanding of spatial dynamics.

\* In this case, given a time series of intensity values at a point, it is possible to "reconstruct" a state space picture of the attractor [8].

Much of the following description, and the categorization used in table II, is based on *observed* similarities in spatial structure. While it may be very difficult to unambiguously state what a complex image is, we as human beings can easily discern between two images and can even say some are "closer" than others in structure. I am not currently aware, however, of any mathematical definition of "closeness" for spatial structure that is of help with the dynamics observed in video feedback. Such a concept would be of immense value in sorting out complex dynamics not only in video feedback but in many other branches of science.

To denote images that are observed to be similar, but different in spatial detail, I introduce the phrase "quasi-attractor" for the associated object in state space. These state space objects appear to be globally stable to small perturbations and it is in this sense that they are attractors. Once perturbed, the video system returns to similar images, although in spatial detail they may be slightly altered from the original.

A good example of quasi-attractors is the class of images displaying *dislocations*. This terminology is borrowed from fluid dynamics, where dislocations refer to the broken structure of convective rolls in an otherwise simple array. Dislocations are regions of broken symmetry where the flow field has a singularity. The formation of this singularity typically requires a small, but significant, energy expenditure\*. In video feedback, dislocations appear as inter-digitated light and dark stripes. The overall pattern can be composed of regular parallel arrays of alternating light and dark stripes with no dislocations, and convoluted, maze-like regions where stripes break up into shorter segments with many dislocations. The

boundaries between segment ends form the dislocations. They can move regularly or wander erratically. Dislocations form in pairs when a stripe breaks in two. They also annihilate by coalescing two stripes. Dislocations make for very complex, detailed patterns whose temporal evolution is difficult to describe in terms of dynamical systems because of their irregular creation and annihilation. Nonetheless, when perturbed very similar images reappear. A quasi-attractor would be associated with global features, such as the relative areas of regular stripe arrays and dislocation regions, the time-averaged number of dislocations, or the pattern's gross symmetry.

Dislocations fall into the behavior class of *spatially decorrelated dynamics*. Moving away from one point on the screen, the spatial correlations decay rapidly enough so that eventually there is no phase relationship between the behavior of different regions. The governing dynamics in any one area is similar to that of other areas. The local behavior, however, can take on the character of a fixed point, limit cycle, or chaotic attractor. Thus while globally stable, the entire image cannot be described by a *single* attractor in the conventional sense of dynamical systems theory. This behavior type has been studied quantitatively in simple nonlinear lattice models [13]. Spatially decorrelated dynamics apparently is the cause of heart fibrillation that results in sudden cardiac death [14].

The existence of *spatial attractors* that describe an image is another useful notion in classifying video dynamics. Intensity values as a function of a "pseudo-time" can be obtained by following along a simple parametrized curve on the screen. These values then can be used to reconstruct a "state space" picture [8] that captures some features of an image's structure. These features naturally depend on the type of curve selected. For example, data from a circle of fixed radius elucidates the rotational symmetry in an image. Similarly, data from along a radial line allows one to study radial wave propagation caused by magnification. The reconstruction of spatial attractors has been carried out for the above-mentioned lattice models [13].

\* Both Couette flow [11] and Bénard convection [12] exhibit this phenomenon. In nematic liquid crystal flow these are called *disclinations*. Similar structures appear in spin systems, such as magnetic bubble devices, and in the formation of crystals. Turing's discussion [6] of "dappled patterns" in a two-dimensional morphogen system is also relevant here.



The rough classification is not yet complete. There are also image sequences that appear to be combinations of spatially-decorrelated dynamics and complex spatial attractors. The latter entries in table II indicate these possibilities.

The interaction of spatial and temporal dynamics makes it very difficult to describe the more complex behavior in any concise manner. To alleviate this problem a short video tape was prepared to illustrate the types of behavior in table II [4]. The movie is particularly effective in giving a sense of the temporal evolution, stability, and richness of video feedback dynamics. An appreciation of the spatial complexity can be gleaned in a few stills from the movie. (See plates 1-7.) This will compensate hopefully those readers who do not have access to a video feedback system or who have not seen the movie.

The examples have a few common features. Regarding parameter settings, they were all made at rotations of approximately 40 degrees and with spatial magnifications slightly less than unity, unless otherwise noted. The discreteness caused by the finite resolution is apparent in each figure. Note that the spatial structures are typically many pixels in extent, so that the discreteness does not play a dominant role.

Plate 1 presents a typical nontrivial equilibrium image, or fixed point. It has an approximate nine-fold symmetry that comes from the rotation angle:  $360/40 = 9$ . The intensity at each point as a function of angle is periodic, with periods not greater than nine. The overall spatial symmetry as a function of rotation  $\phi$  exhibits a "symmetry locking" highly reminiscent of that found in temporal frequency locking in nonlinear oscillators [3]. One noteworthy similarity is that the parameter window for which a given symmetry dominates decreases in width with increased order of the symmetry. For example, spatially symmetric images of period 31 occur for a much smaller rotation range than those with period 9 symmetry.

\* One evening this cycle was allowed to oscillate for two hours with no apparent deviation from periodicity before the power was turned off.

One image out of a long limit cycle is shown in plate 2. The limit cycle period was approximately 7 seconds. Initially, a green disk nucleates at the center of a homogeneous light blue disk. The green disk grows to fill 80% of the illuminated area leaving a blue annulus. A red disk then nucleates inside the green disk, along with an outside ring of nine dots. The oscillation consists largely of the radially outward moving red disk, that intercepts the inward propagating dots. The still is taken at the moment of collision. The disk expands engulfing the dots and the green annulus, then itself is over taken by the inside boundary of the blue annulus that moves inward. The outer boundary of the red disk then recedes before the blue annulus. The screen then eventually becomes entirely light blue, at which moment the center nucleates a growing green disk, and the cycle repeats. This limit cycle was stabilized by a very small marking near the screen's center\*.

Plate 3 shows a still from a sequence of images with slowly moving dislocations. Toward the outside there is a "laminar" region of stripes. Moving inward from this, the first ring of nine dislocations is encountered. These were seen to move smoothly counter-clockwise. The center, however, periodically ejected thin white annuli that propagated out radially, only slowly acquiring clockwise rotation. The interface between the inner and outer regions caused the intervening maze-like dislocation pattern. The entire image shows a high degree of nine-fold symmetry although in the dislocation region it is quite complex.

Spiral patterns are quite abundant, as one expects from a transformation with rotation and magnification. Plate 4 illustrates a *logarithmic spiral* that dynamically circulates clockwise outward. Temporally, the behavior is periodic with color and structure flowing outward from the center. The rotation here is  $\phi = -30$  degrees. The logarithmic spiral can be easily described as a parametrized curve with angle  $\phi$  and scaling  $b$  controls as follows

$$(x, y) = (bt \cos(\phi \log t), bt \sin(\phi \log t)),$$

with  $t \in [0, 1]$ . Such structure and periodic coloring occur often in organisms, such as budding ferns and conch shells.

With relatively high zoom, or large spatial magnification greater than unity, noise in intensity and spatial structure is exponentially amplified. A common manifestation of this is periodic or random bursts. Plate 5 shows a snapshot of a developed burst that had spiralled counterclockwise out of the center in about one second. After a burst the screen goes dark with faint flickering, until another fluctuation occurs of sufficient magnitude to be amplified into a spiralling burst. The video system's finite resolution can be seen as a graininess on a scale larger than the intrinsic discreteness.

Luminance inversion stabilizes images by amplifying contrast. Black regions map into white and colors map to their opposite. This sharpens boundaries between dark, light, and colored areas in an image. Section VI of ref. 2 discusses this stabilizing effect in more detail. Plate 6 shows an example of the "pinwheels" that dominate the images found with luminance inversion\*. The rotation for this photo was  $\phi = -90$  degrees. By adjusting the rotation, focus, and/or hue, controls the pinwheels are seen to move either clockwise or counterclockwise. Winfree discusses similar "rotating waves" of electrical impulses that cause the heart's coordinated beating. Plate 6 should be compared to the figure on page 145 of ref. 14.

Plate 7, also made with luminance inversion, is a snapshot of outward spiralling "color waves". These are very reminiscent of the ion concentration waves found in the Belousov-Zhabotinsky chemical reaction [15]. The rotation parameter here is roughly  $\phi = -40$  degrees. As in the above pinwheels, every point in the image has a well-defined temporal phase, except for the center where there is a phase singularity.

A digital simulation based on eqs. (4) and (7) captures some of the gross features of video feedback. To this extent the proposed models are

correct. It is still an open question as to whether they reproduce the detailed spatio-temporal dynamics. Such comparison is a difficult proposition even in modeling temporal chaos alone. Digital simulations are many orders of magnitude slower than the space-time analog simulations of video feedback. And for this reason it is difficult, given model equations, to verify in detail and at numerous parameter settings their validity. To date digital simulations [7] have reproduced the following features typical of video feedback:

- 1) equilibrium images with spatial symmetry analogous to Turing's waves [6];
- 2) fixed point images stable under perturbation;
- 3) meta-stability of fixed point images: sufficiently large perturbations destroy the image;
- 4) logarithmic spirals;
- 5) logarithmic divergence when the rasters are not centered.

At this preliminary stage of digital simulation it is not possible to discuss much in detail. In fact, it may be a long time until extensive digital simulations are carried out on the proposed models. The construction of, or use of pre-existing, special purpose digital image processors to simulate video feedback may be more feasible than using conventional digital computers. The next and final section comes back to address these questions of future prospects for understanding video feedback.

## 5. Variations on a light theme

Video feedback is a fast and inexpensive way to perform a certain class of space-time simulations. It also provides an experimental system with very rich dynamics that is describable in some regimes by dynamical systems theory, while in other regimes it poses interesting questions about extending our current descriptive language to spatial complexity.

One goal in studying video feedback is to see whether it could be used as a simulator for dynamics in other fields. Turing's original proposal of reaction-diffusion equations for biological mor-

\* Bob Lansdon introduced me to these pinwheel images. See also ref. 2.

phogenesis comes to mind, as well as the image processing [16] and hallucinogenic dynamics [17] of the visual cortex. Naturally, the first task in this is to understand video feedback itself as completely as possible. Toward this immediate end, I have proposed models based on video physics and presented an overview of the possible behavior in a particular color video system. The next steps in this program are to make a more quantitative study of the attractors and bifurcations with calibrated video components. Data from these experiments would be analyzed using techniques from dynamical systems to (i) reconstruct state space pictures of the simpler attractors, and (ii) quantify the unpredictability of the simple aperiodic behavior.

A second approach to understanding video feedback dynamics is to study other configurations of video components. The possibilities include:

- 1) masking portions of the screen to study the effect of boundary conditions;
- 2) optical processing with filters, lenses, mirrors, and the like;
- 3) using magnets to modulate the monitor electron beam scanning;
- 4) connecting two camera-monitor pairs serially, thus giving twice as many controls;
- 5) nonlinear electronic processing of the video signal;
- 6) inserting a digital computer into the feedback loop via a video frame buffer.

The possible modifications are endless. But, hopefully, they will help point to further understanding and lead to applications in other fields.

Variations (5) and (6) may lead to the most fruitful applications of video feedback. For example, they allow one to alter the governing rules in simulations of two-dimensional local and nonlocal automata. In this process an image is stored each raster time. Each pixel and its neighbors are operated on by some (nonlinear) function. For rapid ("real-time") simulation this function is stored in a "look-up" table. The pixel value and those of its neighbors form the input to the table. The table's result then becomes the pixel's new value that is stored and displayed. This is a very general

configuration. With video feedback one has simple control over the nonlocality of the rules using rotation and spatial magnification, and over the number of neighboring pixels using the focus.

A monochrome system, employing an intensity threshold to give crisp black and white images, could be used to simulate binary cellular automata. This restriction on the intensity range falls far short of the possible pixel information in video systems. Indeed, as discussed in the appendix, color systems are capable of transmitting roughly 20 bits of information per pixel. This includes a random "noise floor" for small signals. Generalizing cellular automata, from a few states per site to many, leads to lattice dynamical systems [13]. This corresponds in the video system to removing the above thresholding. Thus this video configuration will be especially useful in the experimental study of lattice dynamical systems and in the verification of analytic and numerical results, such as spatial period-doubling, found in some nonlinear lattices [13].

A number of video image processors are available, both analog and digital. Many have been constructed solely according to their aesthetic value by video artists. Certainly, among this group there is a tremendous amount of qualitative understanding of video dynamics. At the other extreme of the technical spectrum, some of the emerging supercomputers have adopted architectures very similar to that of video feedback systems. These machines would be most useful in detailed quantitative simulations. And, in turn, video feedback might provide an inexpensive avenue for initial study of simulations planned for these large machines.

Physics has begun only recently to address complex dynamical behavior. Looking back over its intellectual history, the very great progress in understanding the natural world, with the simple notions of equilibrium and utter randomness, is astounding. For the world about us is replete with complexity arising from its intimate interconnectedness. This takes two forms. The first is the recycling of information from one moment to

the next, a temporal inter-connectedness. This is feedback. The second is the coupling at a given time between different physical variables. In globally stable systems, this often gives rise to nonlinearities. This inter-connectedness lends structure to the chaos of microscopic physical reality that completely transcends descriptions based on our traditional appreciation of dynamical behavior.

From a slightly abstract viewpoint, closer to my personal predilections, video feedback provides a creative stimulus of behavior that apparently goes beyond the current conceptual framework of dynamical systems. Video feedback poses significant questions, and perhaps will facilitate their answer. I believe that an appreciation of video feedback is an intermediary step, prerequisite for our comprehending the complex dynamics of life.

### Acknowledgements

I am particularly indebted to Ralph Abraham for introducing me to video feedback a number years ago. Special thanks are due to Doyné Farmer and the Center for Nonlinear Studies, Los Alamos National Laboratory, for the support and encouragement of this project. Larry Cuba generously loaned his video equipment for Plates 6 and 7. Elaine Ruhe was especially helpful in the preparation of the video tape and stills. I would also like to thank the Automata Workshop participants who played with the video feedback demonstration and discussed their ideas with me. Particular thanks go to Bob Lansdon, Alice Roos, Otto Rössler, and Art Winfree, for useful discussions on video feedback.

### Appendix A

#### *Video physics*

There are many types of camera pickup tubes, but for concreteness I will concentrate on the common vidicon tube and describe how it converts an image to an electronic signal. The vidicon relies

on the photoconductive properties of certain semiconductors (such as selenium). When light is incident on these materials their electrical resistance is reduced. Photoconductors can have quite large quantum efficiencies, approaching 100%, with virtually all the incident photon energy being converted to mobilizing electrons in the material. Once energized these electrons diffuse in an ambient electric field.

The vidicon takes advantage of these mobile electrons in the following way. (Refer to fig. 3.) An image is focused on a thin *photoconducting layer* (A) approximately one square inch in size. Spatial variation in an image's light intensity sets up a spatial distribution of mobile electrons. Under influence of a small bias field these diffuse toward and are collected at the transparent *video signal pickup* conductor (B). During operation the photoconductor/pickup sandwich acts as a leaky capacitor with spatially varying leakage: the more incident light, the larger the local leakage current. The *electron beam* (C) from the vidicon's cathode scans the back side of the photoconductor depositing electrons, restoring the charge that has leaked away, and hence, bringing it to a potential commensurate with the cathode. The coils (D) supply the scanning field that moves the electron beam over the photoconductor. They are driven synchronously with the horizontal and vertical raster timing circuits (top of diagram). The output video signal corresponds to the amount of charge locally deposited by the beam at a given position during its scan. This charge causes a change in the leakage current and this change is picked up capacitively and then amplified.

The important features of this conversion process, aside from the raster scanning geometry already described, are

- 1) the diffusion of electrons as they traverse the photoconductor; and
- 2) the local storage and integration of charge associated with the light incident during each raster time.

The diffusion process directly limits the attainable spatial resolution. This places an upper bound on

the number of horizontal lines and the number of *pixels* (distinct picture elements) within each line. The effect on spatial patterns is that there can be no structure smaller than this diffusion limit. Another interpretation of this is that, over the period of several rasters, there is a diffusive coupling between elements of an image.

The high spatial frequency cutoff can be easily estimated. The electron beam forms a dot on the photoconductor's backside approximately 1 to 2 mils in diameter. Diffusion then spreads this out to roughly twice this size by the time these electrons have traversed the layer, yielding an effective 3 to 4 mils minimum resolution. For a vidicon with a one inch square photoconducting target, this results in a limit of 250 to 300 pixels horizontally and the same number of lines vertically. These are in fact nominal specifications for consumer quality cameras. Additionally, although the raster geometry breaks the image into horizontal lines, the resolution within each line is very close to that given by the number of scan lines. It will be a reasonable approximation, therefore, to assume that the spatial frequency cutoff is isotropic.

In a similar manner the charge storage and integration during each raster time places an upper limit on the temporal frequency response of the system. In fact, this storage time  $\tau_s$  can be quite a bit longer than the raster time  $\tau_r$  of 1/30 second. A rough approximation to this would be  $\tau_s \approx 10\tau_r \approx 1/3$  second. Thus the system's frequency response should always be slower than 3 Hz. And this is what is observed experimentally. Even the simplest (linear) model for video feedback must contain spatial and temporal low pass filters corresponding to the above limitations.

The optical system that forms the image on the photoconductor has spatial and temporal bandwidths many orders of magnitude greater than the vidicon itself. Hence these intrinsic optical limitations can be neglected. The optical system controls, however, are quite significant. The focus, for example, can affect an easily manipulated spatial diffusion by moving the image focal plane before or behind the photoconductor. In addition, by

adjusting it to one side of exact focus the diffusion orientation can be inverted. Very small changes in the zoom, or spatial magnification, can have quite large qualitative effects because the image information repetitively circulates in the feedback loop. A spatial magnification greater than unity increases exponentially with the number of passes through the loop. Similarly, adjusting the admitted light with the  $f$ /stop can cause the light in an image to dissipate completely when set below some intrinsic threshold.

The image intensity can again be adjusted with the brightness control on the monitor, perhaps to compensate for the camera's  $f$ /stop setting. The brightness adjusts the DC intensity level of the video signal, while the contrast amplifies its dynamic range, or the AC portion of the video signal. High contrast will amplify any noise or spurious signal into an observable flickering of the image. A monochrome monitor's screen (E) is coated with a uniform layer of phosphor that emits light when struck by the electron beam (G). Using the monitor's driving coils (D), the raster synchronizing circuits move the beam to the appropriate position on the screen for the incoming video signal. This signal modulates the beam's intensity (F). The screen's spatial resolution is effectively continuous with a lower bound significantly less than that imposed by the vidicon resolution and by the finite number of scan lines. Additionally, the phosphor stores each raster for a short time to reduce flickering. Thus there is another image storage element in the feedback loop. The phosphor's *persistence* is typically a single raster time and so it can be neglected compared to the vidicon's storage time.

There are a number of sources of error, or deviations from the idealized video feedback system. Here I will briefly mention a few that could be taken, more or less easily, into account in the modeling, but for simplicities sake will not be included. The first omission that I have made in describing the functioning of video systems, is that the bulk of them transmit two *interlaced* half-rasters, or *fields*, every sixtieth of a second. A

complete raster is still formed every thirtieth of a second, but the successive images appear to flicker less than without interlaced fields. Since the time scale of this is much less than the image storage and integration time of the vidicon it can be neglected.

A second and important error source is the intrinsic noise of the intensity signal. A number of physical processes contribute to this noise. The discreteness of the quantum processes and the electron charge produce resistive noise in the photoconductor. The electronic amplifiers for the signal also introduce noise. The net effect though is a signal to noise ratio of about 40 db. This translates into about 10 mV white noise superimposed on the 1 V standard video signal, or into about 1% fluctuation in the intensity of pixels on the monitor's screen.

The photoconductor's monotonic, but non-linear, current output  $i_0$  as a function of light intensity  $I_i$  adds a third error. For vidicons  $i_0 \sim I_i^\gamma$ , with  $\gamma \in [0.6, 0.9]$ . Furthermore, this response function saturates above some intensity threshold  $I_{\text{sat}}$ . Vidicon photoconductors also exhibit a non-uniform sensitivity of about 1% over the target region.

When the camera is very close to the monitor, there is significant geometric distortion due to the screen's curvature. Geometric distortion also arises from other errors in the system, such as the adjustment of the horizontal and vertical raster scanning circuitry. These distortions can be reduced to within a few percent over the image area. Finally, within the monitor there are saturating nonlinearities in its response to large intensity signals and high brightness or high contrast settings. This list is by no means exhaustive, but at least it does give a sense of the types of errors and their relative importance.

## References

- [1] R. Abraham, "Simulation of Cascades by Video Feedback", Lect. Notes in Math. 525 (1976) 10.
- [2] G. Ferraro and G. Häusler, "TV Optical Feedback Systems", Opt. Eng. 19 (1980) 442; see references in section 5 of S.A. Collins and K.C. Wasmundt, "Optical Feedback and Bistability: a review", Opt. Eng. 19 (1980) 478.
- [3] B. van der Pol, "Frequency Demultiplication", Nature 120 (1927) 363. C. Hayashi, Forced Oscillations in Nonlinear Systems (Nippon, Osaka, Japan, 1953).
- [4] J.P. Crutchfield, "Dynamics in the Space of Images", 1983; 12 min. video tape: U-matic, VHS, and Beta formats.
- [5] See for example R. Abraham and C.D. Shaw, Dynamics - The Geometry of Behavior, vols. I and II, Aerial Press (1982), P.O. Box 1360, Santa Cruz, California 95061; D.R.J. Chillingsworth, Differential Topology with a View to Applications (Pitman, London, 1976); or P. Collet and J.-P. Eckmann, Iterated Maps on the Interval as Dynamical Systems (Birkhäuser, Boston 1980).
- [6] A.M. Turing, "A Chemical Basis for Biological Morphogenesis", Phil. Trans. Roy. Soc. (London), Ser. B, 237 (1952) 37.
- [7] J.P. Crutchfield, in preparation.
- [8] N.H. Packard, J.P. Crutchfield, J.D. Farmer and R.S. Shaw, "Geometry from a Time Series", Phys. Rev. Lett. 45 (1980) 712. See also H. Froehling, J.P. Crutchfield, J.D. Farmer, N.H. Packard and R.S. Shaw, "On Determining the Dimension of Chaotic Flows", Physica 3D (1981) 605.
- [9] See section 9 of ref. 6 and J.D. Farmer, "Sensitive Dependence to Noise without Sensitive Dependence to Initial Conditions", LANL Preprint.
- [10] For one approach to quantifying spatial complexity see J.P. Crutchfield, Noisy Chaos, Ph.D. dissertation, University of California, Santa Cruz (1983).
- [11] R.J. Donnelly, K. Park, R.S. Shaw and R.W. Walden, "Early Non-periodic Transition in Couette Flow", Phys. Rev. Lett. 44 (1980) 987.
- [12] K.E. Heikes and F.H. Busse, "Weakly Nonlinear Turbulence in a Rotating Convection Layer", New York Acad. Sci. 357 (1980) 28.
- [13] J.P. Crutchfield, "Spatial Complexity in Lattice Dynamical Systems: The Logistic and Circle Lattices", in preparation.
- [14] A.T. Winfree, "Sudden Cardiac Death: A Problem in Topology", Sci. Amer. 248(5) (1983) 144.
- [15] See for example A.T. Winfree, "Singular Filaments Organize Chemical Waves in Three Dimensions: Parts 1, 2, and 3", Physics 8D (1983) 35; 9D (1983) 65; and to be published.
- [16] J. Herault, G. Bouvier and A. Chehikan, "A New Algorithm for Image Processing based on the Properties of Neutral Nets", J. Phys. Lett. 41 (1980) L-75.
- [17] J.D. Cowan, "Spontaneous Symmetry Breaking in Large Scale Nervous Activity", Int. J. Quant. Chem. 22 (1982) 1059.

# NOTES FOR AN EARLY ANIMATION DEVICE

Lee Harrison

*The following paper is reprinted in facsimile form as the most primary and authentic source of Lee Harrison's original concept for electronic animation. These notes eventually materialized as the ANIMAC animation system. —D.D.*

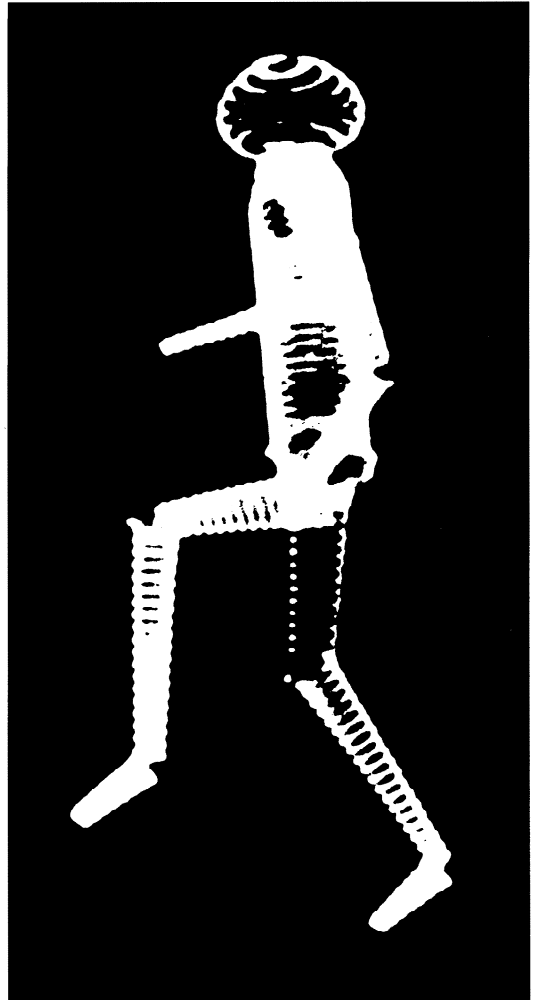

Withstand by Luben Co. 12/29/61

THE CLOCK OR MASTER OSCILLATOR, IS A ~~VERY~~ STABLE, VARIABLE-FREQUENCY WAVEFORM GENERATOR. ~~THE OUTPUT OF THE CLOCK~~  
 THERE ARE TWO ~~OR~~ SIGNAL OUTPUTS OF THE CLOCK OR MASTER OSCILLATOR. ONE IS A SQUARE WAVE ~~WAVE~~, ~~THE~~ OTHER, A SINE WAVE. ~~THE~~ OUTPUTS ARE AT THE SAME FREQUENCY. ~~←~~  
 THE FUNCTION OF THE CLOCK IS TO FURNISH THE "DRIVING-SIGNALS" TO THE DEVICE. ~~IT~~ IS ALSO A MEANS BY WHICH THE <sup>INNER</sup> WORKINGS OF THE DEVICE ARE "TIME-SYNCHRONIZED."  
 WE REFER TO THE OUTPUT OF THE CLOCK AS "HIGH FREQUENCY," ~~BECAUSE~~ BECAUSE WE COUNT DOWN (BY MEANS OF A COUNTER TO BE DESCRIBED LATER) TO THE "FRAME FREQUENCY", ~~OR~~ ~~IS~~ ~~THIS~~ ESTABLISHING A FRAME RATE. FRAME RATE IS THE <sup>OR</sup> RATE AT WHICH WE DRAW ONE COMPLETE FIGURE <sup>ON</sup> THE DISPLAY SCOPE.  
 BECAUSE THE COUNTER PERFORMS A FIXED-RATIO-COUNTDOWN, THE LOW FREQUENCY IS ALWAYS A LOWER MULTIPLE OF THE HIGH FREQUENCY. ~~THUS,~~ BY VARYING THE HIGH FREQUENCY, WE AUTOMATICALLY VARY THE LOW FREQUENCY OR FRAME RATE.  
 DURING THIS DEVELOPMENTAL PERIOD, WE <sup>ARE</sup> OPERATING AT FRAME RATES BETWEEN 24 AND 30 CYCLES PER SECOND (CPS). 30 cps IS DESIRABLE AT THIS TIME BECAUSE  
 a.) THE LIGHTING IN OUR WORKSHOP IS SUCH THAT AT A LOWER FRAME RATE, WE SEE A BOTHERSOME FLICKER, and  
 b.) IT IS VERY EASY TO SYNCHRONIZE THE FREQUENCIES TO "20-CYCLE LINE FREQUENCIES" (JUST TWICE THE FRAME RATE) <sup>WITH A HAND ADJUSTMENT OF THE</sup> AND THEREBY ELIMINATE WHAT IS KNOWN AS "HUM" OR LINE NOISE, WHICH IF NOT SYNCHRONIZED CAUSES A SLOW WOBBLE OF THE PICTURE.  
 IN THE FUTURE, WE WILL INSTALL A FEEDBACK TIMING-CONTROL IN THE COUNTER CIRCUIT WHICH WILL AUTOMATICALLY SYNCHRONIZE ALL FREQUENCIES TO THE LINE (60CPS) AND

AND HAS BEEN CALLED BY THE  
 JEN. TIME M.L.T. 9. 11/27/61  
 TODAY IS DEC. 29, 1961  
 11/27/61

page 2

Leuth...

THIS ELIMINATE THE NECESSITY OF HAND ADJUSTMENTS AND ALSO ASSURE AN EXACT 24 CPS FRAME RATE.



DEC 29 1961

THE SQUARE WAVE OUTPUT IS FED DIRECTLY INTO THE COUNTER. IT IS ALSO <sup>FEED INTO AUDIO</sup> THE DRIVING SIGNAL FOR THE HORIZONTAL DEFLECTION GENERATOR OF THE BKIN SCANNER (TO BE DESCRIBED LATER.)

THE SINE WAVE OUTPUT IS FED INTO TWO OF THE <sup>TO BE DESCRIBED LATER</sup> SAMPLERS (SAMPLER GATES), ~~AND~~ ALSO INTO A 90 DEGREE PHASE SHIFTER WHOSE OUTPUT NOW BECOMES A COSINE WAVE (IN RELATION TO THE ORIGINAL SINE WAVE) ~~AND~~ WHICH IS SUBSEQUENTLY FED INTO THE OTHER SET OF SAMPLERS. ALSO BOTH SINE AND COSINE WAVES ARE FED INTO MODULATORS (TO BE DESCRIBED LATER)

THE FUNCTION OF THE CLOCK MAY BE TAKEN OVER BY THE TAPE RECORDER, WHERE THE CLOCK SIGNALS ARE RECORDED ON ONE OF THE CHANNELS, AND USED AS DRIVING SIGNALS OF THE DEVICE, THIS SYNCHRONIZING ALL RECORDED SIGNALS WITH THE "TAPE CLOCK".



COUNTER & TIMING CONTROL

Lee Harrison  
W1816 2/23/61

THE COUNTER IS A CHAIN OF BISTABLE MULTIVIBRATORS. THE INPUT TO THE FIRST BSMV IN THE CHAIN IS THE HIGH FREQUENCY SQUARE WAVE FROM THE CLOCK. THE OUTPUT OF THE FIRST BSMV IS A SQUARE WAVE WHICH IS EXACTLY  $\frac{1}{2}$  THE FREQUENCY OF THE INPUT. THUS EACH BSMV IN THE CHAIN HALVES ITS INPUT FREQUENCY.

AT THE PRESENT TIME WE HAVE 9 BSMV'S IN THE COUNTER CHAIN. THIS GIVES A COUNTDOWN RATIO OF 512:1. THUS FOR A FRAME RATE OF 24 FRAMES/SEC, THE HIGH FREQUENCY MUST BE 12,288 CPS

THERE IS NOTHING MAGIC ABOUT THIS SELECTED RATIO OF 512 TO 1. THE CHOICE OF IT AT THIS TIME WAS GOVERNED BY THE EASE WITH WHICH WE ARE ABLE TO USE THE HIGH FREQUENCY IN THE FUNCTION (SINE-COSINE) GENERATOR NETWORK. IF THE FREQUENCIES USED IN THAT NETWORK GET TOO HIGH, THE GENERATOR DOES NOT PERFORM AS WELL AS WE'D LIKE IT TO. WE HAVE NOT HAD TIME TO REDESIGN THE NETWORK. HOWEVER, IT WORKS WELL UP TO 16 OR 17 KC. EASILY ALLOWING A 30 FPS FRAME RATE.

OF COURSE, THE HIGHER FREQUENCY WE USE, THE GREATER "BONE & SKIN" RESOLUTION WE MAY HAVE (THIS WILL BE EXPLAINED LATER.)

THE OUTPUT OF THE FIRST BSMV, BESIDES BEING FED INTO THE 2<sup>ND</sup> BSMV, IS ALSO FED INTO THE DELAY MULTIVIBRATORS IN THE AFORE-MENTIONED SINE-COSINE FUNCTION GENERATOR NETWORK, AND ACTS AS A DRIVING SIGNAL FOR THOSE DELAY MV'S. IN OTHER WORDS, IT CAUSES THE DELAY MV'S TO ~~BE~~ <sup>ALLOW</sup> A SAMPLING OF

THE SINE AND COSINE WAVES IN THE SAMPLERS AT  $\frac{1}{2}$  THE FREQUENCY OF THE SINE & COSINE WAVES IN THE SAMPLERS. ~~AT THESE~~ ARE 2 CYCLES TO SAMPLE FROM,

COUNTER, WILL ARRIVE AT 60 CPS (AS ACCURATELY AS THE LINE FREQUENCY IS 60 CPS) AT THE BACK END OF THE COUNTER. FOR USE WITH A TUBE OSCILLATOR WOULD BE ADVANCED BY A HIGHER SPEED OSCILLATOR, WHICH WOULD ACCURATELY REGULATE THE TIME SPEED, AND THUS THE FREQUENCIES COMING OFF THE FRONT.

page 4

Lee Harrison

THE SIGNIFICANCE OF THIS IS THAT WE CAN GET MORE THAN A 360 ROTATION, ~~IN~~ A BONE. (TO BE DESCRIBED MORE FULLY)

THE TIMING CONTROL IS A FEEDBACK NETWORK WHICH <sup>AUTO-MATICALLY</sup> SYNCHRONIZES <sup>ALL OF THE DRIVING</sup> AT THE ~~A~~ FREQUENCIES (A HIGH & LOW) TO THE 60 CPS LINE-FREQUENCY, THUS ~~ASSURING~~ ASSURING AN EXACT 24 FPS FRAME RATE.

[HUM] THE ELECTRONIC EQUIPMENT OPERATES ON POWER RECEIVED FROM A 60 CYCLE SUPPLY LINE. THIS POWER AT 60 CPS IS PRESENT IN WIRES AND CABLES NEAR & THRU THE EQUIPMENT, AND HAS A TENDENCY TO RADIATE A CERTAIN AMOUNT OF THIS POWER TO ADJACENT PARTS, THE RESULT IS THAT THERE IS ALWAYS PRESENT A SLIGHT VOLTAGE RIPPLE ON THE LINES, IN THE AMPLIFIERS, AND EVEN IN THE D.C. REGULATED-VOLTAGE SUPPLIES. THIS MAY BE ELIMINATED BY ~~EXCESSIVE~~ SHIELDING AND ~~SUPPRESSING~~ <sup>REDUCING</sup> THE OPERATION OF THE SUPPLIES, OR IT MAY BE COMPENSATED FOR BY SYNCHRONIZING ALL OF THE <sup>OPERATING</sup> FREQUENCIES TO THIS HUM. FOR EXAMPLE, LET US SUPPOSE WE ARE OPERATING AT 23.999 FRAMES PER SECOND, AND THE LINE RIPPLE IS AT 60 CPS, THE PICTURE WILL TEND TO SLOWLY UNDULATE BECAUSE OF A BEAT SET UP BY THE TWO, NON-MULTIPLE FREQUENCIES. HOWEVER, BY MAKING THE FRAME RATE EXACTLY 24 FPS, WE WILL DRAW A COMPLETE FRAME FOR EVERY 30 CYCLES OF HUM.

THERE ARE 2 INPUTS TO THE TIMING CONTROL: ONE IS THE 24 CPS FROM THE COUNTER, THE OTHER IS 60 CPS FROM THE LINE. THE 24 CPS FRAME RATE IS FED INTO A BSMV WHOSE OUTPUT IS THEREFORE 12 CPS, THE LINE FREQUENCY (60 CPS) IS FED INTO A 5:1 COUNTER (BINARY FEEDBACK TYPE) AND ITS OUTPUT IS 12 CPS. THESE 2 FREQUENCIES ARE THEN FED INTO A PHASE-COMPARATOR. THE OUTPUT OF THE PHASE-COMPARATOR (A D.C. VOLTAGE) IS FED INTO A D.C.-CONTROLLED OSCILLATOR WHOSE MEAN OUTPUT FREQUENCY WILL BE TUNED TO HIGH FREQUENCY WHICH WHEN FED INTO THE FRONT END OF THE

## ELECTRONIC GATE-COMMUTATOR OR MONOSTABLE MULTIVIBRATOR CHAIN

THE CHAIN OF ~~MONOSTABLE~~ MONOSTABLE MULTIVIBRATORS (MSMV) IS AN ELECTRONIC COMMUTATOR WHICH OPENS AND CLOSES A SERIES OF "BONE" GATES IN A SEQUENTIAL MANNER. IN OTHER WORDS, THE MSMV'S FURNISH THE DRIVING (OPENING & CLOSING) SIGNALS TO THE GATES.

THE INPUT TO THE FIRST MSMV IN THE CHAIN IS A <sup>FRAME-RATE</sup> PULSE (SAY 30 CPS) WHICH COMES FROM THE COUNTER. WHEN THE PULSE ARRIVES, IT CAUSES THE MSMV TO FLIP INTO ~~ITS~~ ITS OTHER (UNSTABLE) STATE, FOR A LENGTH OF TIME AS DETERMINED BY ITS INTEGRAL RC NETWORK. BY VARYING R, THE LENGTH OF TIME DURING WHICH THE MSMV IS IN ITS UNSTABLE STATE MAY BE VARIED. ~~WHEN THIS TIME HAS LAPSED,~~ DURING THIS "OPEN" TIME, A CHANGE IN VOLTAGE OCCURS ON ONE OF ITS OUTPUTS. THIS VOLTAGE IS USED TO OPEN A NUMBER OF GATES CONNECTED TO IT. WHEN THE "OPEN" TIME HAS LAPSED, THE MSMV AUTOMATICALLY FLIPS BACK INTO ITS ORIGINAL STATE (STABLE) AND CHANGES BACK THE OUTPUT VOLTAGE DRIVING THE GATES, THUS CLOSING THEM. DURING THE FLIP-BACK, A PULSE SIMILAR TO THE ONE THAT CAUSED THE ORIGINAL FLIP IS GENERATED AT ANOTHER OUTPUT POINT, AND THENCE IS SENT TO THE NEXT MSMV IN THE CHAIN WHERE A SIMILAR OPERATION OCCURS, THUS OPENING THE NEXT GROUP OF ASSOCIATED GATES FOR A TIME DESCRIBED BY THE R ASSOCIATED WITH THAT 2<sup>nd</sup> MSMV. THIS COMMUTATING ACTION CONTINUES UNTIL ALL THE MSMV'S IN THE CHAIN HAVE GONE THROUGH THEIR INDIVIDUAL CYCLES.

THE "DRIVING OUTPUT" OF THE MSMV'S (SHOWN IN FIG. 1.) IS USE TO PERFORM A NUMBER OF TASKS. FOR EXAMPLE, THIS OUTPUT MAY BE USED TO CLOSE THE ELECTRONIC SWITCHES ACROSS THE

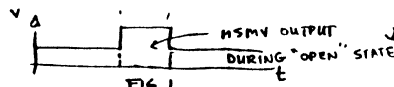

INTEGRATING CAPACITORS, THUS CAUSING THE DISPLAY BEAM TO "FLY BACK" TO ITS STARTING POINT. ~~THESE SIGNALS ARE USED THEREFORE AS INPUTS TO THE FLYBACK CIRCUIT,~~ <sup>ADD THE DELAY TIME</sup> BE DESCRIBED LATER IN MORE DETAIL. ANOTHER USE OF THE MSMV OUTPUT IS TO DIM OR BLANK-OUT THE DISPLAY BEAM. BY APPLYING THE MSMV OUTPUT TO THE GRID OF THE DISPLAY CRT, THE BEAM IS "TURNED -OFF" DURING THE "OPEN" TIME OF THE MSMV SO ENGAGED. IN THIS MANNER, FLYBACK RETRACES, AND CERTAIN BONE-PLACING RETRACES - (AS IN THE ARMS, WHERE THE BEAM MUST MOVE FROM THE STARTING POINT, UP TO THE SHOULDER AND THENCE PROCEED TO DRAW THE ARM, AND DURING THAT "PLACEMENT" BONE DRAWING, THE BEAM IS BLANKED OUT) MAY BE BLANKED OUT AS ~~BEFORE~~;

AS MENTIONED BEFORE, THE LENGTH OF TIME THAT AN MSMV REMAINS IN ITS OPEN POSITION IS DETERMINED BY R OF THE INTEGRAL RC NETWORK. THUS BY VARYING <sup>EACH</sup> OF THE RESISTANCES ASSOCIATED WITH EACH MSMV-RC-NETWORK, AN OPERATOR IS ABLE TO "SET-UP" A FIGURE OR CHARACTER TO HAVE THE DESIRED "BONE" LENGTHS, AND OVERALL STRUCTURE. HE ALSO, IN THIS SETUP PROCEDURE, DETERMINES THE SEQUENCE IN WHICH THE PARTICULAR BONES WILL BE DRAWN. IN DETERMINING THIS SEQUENCE HE MAKES THE NECESSARY CONNECTIONS, ~~THE FLYBACK CIRCUIT,~~ <sup>AND</sup> BLANKING CIRCUIT. IN ADDITION TO DETERMINING AND SETTING UP THE DESIRED BONE LENGTHS.

THE MSMV CHAIN IS A SWITCHING, COMMUTATING NETWORK WHICH REGULATES THE OPENING AND CLOSING OF THE BONE GATES, ~~THE~~ THE VARIOUS TASKS WHICH IT PERFORMS COULD BE DONE IN OTHER WAYS, SUCH AS (a) MECHANICAL SYSTEMS (b) BINARY COUNTER SYSTEMS WITH AND/OR DIODE NETWORKS (c) OTHER ELECTRONIC ARRANGEMENTS (d) ~~MECHANICAL~~ MECHANICAL SYSTEMS.

## BONE GATES.

ASSOCIATED WITH EACH BONE, AND BEING DRIVEN BY A MSMV OF THE MSMV CHAIN, ARE A NUMBER OF ELECTRONIC GATES. THE GATES ARE NORMALLY CLOSED, BUT ARE OPENED BY THE RECTANGULAR WAVE FORM RECEIVED FROM THEIR DRIVING MULTIVIBRATOR. THERE IS AN OUTPUT FROM THE GATE ONLY DURING THE "OPEN" PERIOD, AND THE NATURE OR CHARACTER OF THIS OUTPUT IS A FAITHFUL REPRODUCTION OF THE GOVERNED BY THE INPUT SIGNAL. IF THE INPUT IS A D.C. SIGNAL, THEN THE OUTPUT WILL BE A CORRESPONDING D.C. SIGNAL, (SIMILARLY IF THE INPUT IS A SINE WAVE OR OTHER SHAPED SIGNAL, THE OUTPUT WILL LOOK LIKE THE INPUT.) IN OTHER WORDS, THE GATE PASSES OR ALLOWS TO PASS THRU IT ANY SIGNAL THAT IS PRESENT AT ITS INPUT DURING THE "OPEN-PERIOD" OF THE GATE.

THE GATES FOR EACH BONE ARE IN PARALLEL, AND OPERATE SIMULTANEOUSLY, AND SEND SIGNALS TO DIFFERENT PARTS OF THE DEKKE IN ORDER TO "MAKE" BONES AND CONTROL THEIR POSITIONS IN SPACE. A GATED D.C. WAVEFORM (AS WILL BE SHOWN LATER) MAKES A STRAIGHT BONE. A GATED "SHAPED" WAVEFORM WILL MAKE A BONE ~~WHOSE~~ WHOSE AXIS IS NOT STRAIGHT, BUT HAS THE INTEGRATED, VECTORIAL DIRECTION (OR SHAPE) PRESCRIBED BY THE SHAPED INPUT.

FOR EACH BONE, THE D.C. VOLTAGE APPLIED TO THE FIRST GATE, THE ANGLE ( $\theta$ ) THAT THE BONE MAKES WITH THE X-AXIS OF THE DISPLAY IS VARIED. A VARIABLE POTENTIOMETER MAY BE USED TO VARY THE INPUT VOLTAGE, (OR OTHER MEANS MAY BE USED, OF COURSE). THE SECOND GATE IS USED TO CONTROL THE ANGLE THAT THE BONE MAKES WITH THE X-Y PLANE, IN SIMILAR FASHION

Page 8

Lithium

BY VARYING THAT D.C. INPUT, THE THIRD GATE IS USED TO CONTROL THE ANGULAR POSITION (OR MAY BE CALLED "ROTATIONAL POSITION") OF THE SKIN ON THE BONE.

ADDITIONAL GATES MAY BE USED IN SIMILAR FASHION TO CONTROL OTHER PARAMETERS OF THE BONE - SUCH AS INTENSITY, TEXTURE ETC.

THE FIRST TWO GATES CALLED " $\theta$ " AND " $\phi$ " SEND THEIR SIGNALS TO ~~THE~~ <sup>THE</sup> SIMILAR, ANGLE-PRODUCING NETWORKS. THESE SIGNALS MAY ALSO BE SENT TO CORRESPONDING CHANNELS OF THE TAPE RECORDER, SO THAT DURING PLAYBACK THESE MULTIPLEXED SIGNALS WILL DRIVE THE BONE AND SKIN PRODUCING MECHANISMS OF THE DEKKE, THIS AUTOMATICALLY PRODUCING THE PREVIOUSLY RECORDED MOVEMENTS OF THE BONE & ASSOCIATED PARTS.

THE OUTPUTS OF CONSECUTIVE  $\theta$  GATES ARE ALL FED INTO THE  $\theta$ -SINE-COSINE FUNCTION-GENERATOR AND SIMILARLY THE OUTPUTS OF  $\phi$  GATES INTO THE  $\phi$  SINE-COSINE FUNCTION GEN.

SINE-COSINE FUNCTION GENERATOR

*See Hermann TB*

THERE ARE 2 SINE-COSINE FUNCTION GENERATORS. ONE RECEIVES ITS INPUT FROM THE  $\Theta$ -GATES, THE OTHER FROM THE  $\Phi$ -GATES. EACH GENERATOR HAS 2 OUTPUTS FOR EACH INPUT. THE RANGE OF VOLTAGES AT THE INPUT REPRESENT ANY DESIRED ANGULAR POSITION OF THE BONE, AND THE TWO VOLTAGE OUTPUTS HAVE THE RELATION OF THE SINE AND COSINE RESPECTIVELY (SEE GENERAL THEORY)

IN ORDER TO PRODUCE THE RELATIVE VALUES OF THE SINE AND COSINE, SAMPLES OF SINE AND COSINE WAVES ARE TAKEN AT REGULAR INTERVALS, AND THESE SAMPLES ARE FED INTO CAPACITORS WHICH HOLD THE SAMPLED VOLTAGES TO PRODUCE D.C. VOLTAGES ACROSS THE CAPACITORS WHICH ARE AT THE LEVELS BEING SAMPLED.

A SINE-COSINE FUNCTION GENERATOR HAS IN ITS NETWORK A DELAY MULTIVIBRATOR, A NARROW-OUTPUT MONOSTABLE MULTIVIBRATOR, 2 WAVE-SAMPLING GATES AND A HOLDING CAPACITOR ON THE OUTPUT OF EACH SAMPLING GATE. THE DELAY MULTIVIBRATOR HAS TWO INPUTS. ONE INPUT COMES FROM THE 2<sup>ND</sup> STAGE OF THE COUNTER, AT  $\frac{1}{2}$  THE HIGH-FREQUENCY AND IS OF THE SQUARE WAVE TYPE. THIS INPUT CAUSES THE DELAY M.V. TO CHANGE STATES. IT WILL REMAIN IN THIS STATE UNTIL IT FLIPS BACK AUTOMATICALLY INTO ITS ORIGINAL STATE. THE LENGTH OF TIME THAT IT REMAINS IN THE UNSTABLE STATE IS DETERMINED BY THE 2<sup>ND</sup> INPUT. THIS 2<sup>ND</sup> INPUT (WHICH COMES FROM THE GATES) IS A D.C. VOLTAGE WHOSE VALUE DETERMINES THE LENGTH OF TIME THE DELAY M.V. WILL DELAY.

THE DRIVING INPUT... THE MEAN FREQUENCY... THIS MEANS THAT THE DELAY M.V. PERFORMS ITS FUNCTION ONCE FOR EVERY 2 CYCLES OF THE HIGH FREQUENCY. THIS MEANS A SAMPLING OF INTO SQUARE WAVE PULSES... CYCLES OF THE WAVES, WHICH ALIGNS FOR A SQUARE-WAVE SIGNAL OF PERIOD THAT IS 200... PERIODS.

page 10  
AND  
WOULD BE REQUIRED THAT THERE BE ONE FOR EACH GATE, CONTROLLING INPUT FROM MMSV  
DEC 29 1954  
IT WOULD BE REQUIRED THAT THERE BE ONE FOR EACH GATE, CONTROLLING INPUT FROM MMSV  
IT WOULD BE REQUIRED THAT THERE BE ONE FOR EACH GATE, CONTROLLING INPUT FROM MMSV



*See Hermann TB*

THE OUTPUT OF THE DELAY M.V. IS DIFFERENTIATED AND CLIPPED, SO THAT ONLY A PULSE REPRESENTING THE TRAILING EDGE OF THE CHANGE-OF-STATES IS SENT ON TO THE NARROW-PULSE MMSV.

THE INPUT TO THE NARROW PULSE MMSV IS A NARROW TRIGGER PULSE COMING FROM THE DELAY M.V. THE OUTPUT OF THE MMSV IS A VERY NARROW, STRAIGHT SIDED PULSE WHICH IS USED TO DRIVE (OR OPEN) 2 SAMPLING GATES. THE GATES ARE VERY FAST ACTING. ANOTHER INPUT TO THE GATES IS A SINE WAVE (TO ONE) AND A COSINE WAVE (TO THE OTHER) COMING FROM THE SINE WAVE GENERATOR (CLOCK) AND FROM THE PHASE-SHIFTER RESPECTIVELY, THUS THE OUTPUT OF THE GATES IS A VERY NARROW PULSE WHOSE HEIGHT (OR VALUE OF VOLTAGE) IS DETERMINED BY THE TIME AT WHICH THE SINE AND COSINE WAVES WERE SAMPLED, WHICH TIME WAS DETERMINED BY THE TRAILING EDGE OF THE DELAY M.V. WHICH TIME WAS DETERMINED BY THE D.C. VOLTAGE IMPRESSED UPON IT, THIS VOLTAGE HAVING BEEN DETERMINED BY THE OUTPUT OF THE BONE GATES. THE NUMBER OF SUCH PULSES FOR ANY GIVEN D.C. VALUE IMPRESSED UPON THE DELAY M.V. IS DETERMINED BY THE LENGTH OF ANY GIVEN BONE.

BECAUSE OF THE HOLDING CAPACITOR ASSOCIATED WITH THE OUTPUT OF EACH SAMPLING GATE, THERE APPEARS ACROSS EACH CAPACITOR A D.C. VOLTAGE REPRESENTING A PARTICULAR VALUE OF SINE OR COSINE FOR A NORMAL-LENGTH BONE. THE HOLDING CAPACITOR MAY BECOME 10 OR 20 SAMPLING PULSES DURING THE TIME THE BONE IS BEING GENERATED.

THERE ARE OTHER WAYS OF GENERATING THIS SINE-COSINE FUNCTION, ONE SIMPLE WAY WOULD BE TO LET THE OUTPUT OF THE BONE GATES SUPPLY VOLTAGE TO ASSOCIATED SINE-COSINE POTENTIOMETERS BUT THESE POTS ARE EXPENSIVE AND...

# ONE INTEGRATORS

Lee Harrison

W19818 Z-330

THE INTEGRATOR IS A HIGH GAIN AMPLIFIER WHICH HAS A FEEDBACK CAPACITOR TO ITS INPUT. ITS FUNCTION IS TO PERFORM CONTINUOUS INTEGRATION OF THE SIGNALS PRESENTED TO ITS INPUT. THERE ARE THREE INTEGRATORS IN THE BONE GENERATOR, ONE FOR EACH COORDINATE (X, Y, Z) OF A FIGURE.

IF THE INPUT TO AN INTEGRATOR IS A D.C. VOLTAGE, THE OUTPUT IS A RAMP FUNCTION. THE INITIAL CONDITIONS (STARTING VOLTAGES ON THE OUTPUT WHICH DETERMINE THE STARTING POINT OF EACH BONE ON THE DISPLAY) ARE DETERMINED BY THE VOLTAGE ACROSS THE FEEDBACK CAPACITOR. IF THERE IS NO DISCHARGE OF THAT CAPACITOR, THEN THE OUTPUT OF THE INTEGRATION OF

A SEQUENCE OF D.C. VOLTAGES WILL BE JOINED TOGETHER. WHENEVER THE CAPACITOR IS DISCHARGED OR "SHORTED OUT", THE INITIAL CONDITION VOLTAGES ARE RETURNS TO A "ZERO" OR STARTING POSITION. (THE FLYBACK CIRCUIT TO BE DESCRIBED PERFORMS THE FUNCTION OF SHORTING OUT & DISCHARGING THE CAPACITOR AS DESIRED OR REQUIRED TO DRAW A FIGURE OR IMAGE.)

THE VALUE OF VOLTAGE PRESENTED TO THE INPUT OF AN INTEGRATOR DETERMINES THE RATE OF CHANGE OF VOLTAGE AT THE OUTPUT. (SLOPE). IF THE D.C. INPUT VOLTAGES TO THE X AND Y INTEGRATORS REPRESENT THE COS  $\theta$  AND SIN  $\theta$  RESPECTIVELY THEN THE OUTPUT OF THE INTEGRATORS WHEN FED INTO THE HORIZONTAL AND VERTICAL AMPLIFIERS ON A DISPLAY SCOPE WILL CAUSE THE BEAM TO DRAW A LINE ON THE SCOPE WHOSE ANGLE TO THE HORIZONTAL IS  $\theta$ .

W19818 Z-330

ST MAGNIFY THERE

page 12

Lee Harrison

INTERMEDIATE VIEWS MAY BE OBTAINED BY COMBINING ALL THREE INTEGRATOR OUTPUTS IN PROPER AMOUNTS; THIS ALLOWING AN OPERATOR OF THE DEVICE TO VIEW THE OBJECT OR FIGURE FROM ANY POSITION. THE FUNCTION OF COMBINING THESE INTEGRATOR OUTPUTS IN A PROPER FASHION IS CARRIED OUT BY THE "CAMERA ANGLE NETWORK" TO BE DISCUSSED LATER.



DEC 2 1950

THE VALUE OF VOLTAGE PRESENTED TO THE INPUT OF AN INTEGRATOR DETERMINES THE RATE OF CHANGE OF VOLTAGE AT THE OUTPUT. (SLOPE). IF THE D.C. INPUT VOLTAGES TO THE X AND Y INTEGRATORS REPRESENT THE COS  $\theta$  AND SIN  $\theta$  RESPECTIVELY THEN THE OUTPUT OF THE INTEGRATORS WHEN FED INTO THE HORIZONTAL AND VERTICAL AMPLIFIERS ON A DISPLAY SCOPE WILL CAUSE THE BEAM TO DRAW A LINE ON THE SCOPE WHOSE ANGLE TO THE HORIZONTAL IS  $\theta$ .

## FLYBACK NETWORK.

THE FUNCTION OF THE FLYBACK NETWORK IS TO SHORT OUT OR DISCHARGE THE CAPACITORS (C) ASSOCIATED WITH THE INTEGRATORS AT DESIRED TIMES DURING THE SEQUENCE OF BONES AND AT THE END OF ONE CYCLE OF BONE GENERATION. DISCHARGING OF THE CAPACITORS CAUSES THE BEAM OF THE DISPLAY CRT TO FLY BACK TO THE STARTING POSITION.

AN ELECTRONIC SWITCH DISCHARGES THE CAPACITOR. PULSES WHICH CLOSE THE SWITCH COME FROM AN AMPLIFIER WHICH IS IN TURN FED BY PULSES (WHICH ARE SELECTED AS DERIVED) COMING FROM SELECTED MULTIVIBRATORS OF THE MSMV CHAIN. ALSO, A PULSE (WHOSE DURATION IS DETERMINED BY THE TIME OF THE LAST MSMV TO THE BEGINNING OF A NEW CYCLE OF THE FIRST MSMV IS GENERATED BY A BISTABLE MULTIVIBRATOR. THIS FLYBACK BISTABLE MV RECEIVES A PULSE FROM THE LAST MSMV AS IT CLOSURES, THIS PULSE FLIPS THE BSMV AND ITS OUTPUT CAUSES THE SWITCHES TO CLOSE, THIS BSMV STAYS IN THE "CLOSED" STATE UNTIL IT RECEIVES ANOTHER INPUT PULSE WHICH THIS TIME COMES FROM THE ~~COUNTER~~ COUNTER, THE SAME PULSE WHICH STARTS THE CHAIN OF MSMV'S.

DIODES CONNECT ALL OF THE PULSE INPUTS TO THE AMPLIFIER WHICH ACTIVATES THE SWITCHES SO AS TO PREVENT PULSES FROM FEEDING BACK INTO THE GATES AND THUS OPERATE OUT OF SEQUENCE.

THE ELECTRONIC SWITCHES REMAIN CLOSED DURING THE DURATION OF A PULSE, BE IT LONG OR SHORT.

## FLYBACK NETWORK.

THE FUNCTION OF THE SKIN NETWORK IS TO ALGEBRAICALLY COMBINE THE VARIOUS VOLTAGE REPRESENTATIONS OF  $\sin \theta$ ,  $\cos \theta$ ,  $\sin \phi$ ,  $\cos \phi$ ,  $K_1 t_x$ ,  $K_1 t_y$ ,  $K_1 t_z$ ,  $\sin k_1 t$  AND THE VIDEO SIGNAL "A" TO GIVE THE PROPER FORMULATIC REPRESENTATIONS OF THE GEOMETRIC PROJECTIONS OF THE FIGURE OR OBJECT BEING GENERATED. FOR QUICK REFERENCE, A SIGNALS TABULAR REPRESENTATION OF THESE VARIOUS SIGNALS IS GIVEN BELOW.

$K_1 t_x$   
to  
input x.

$K_1 t_y$   
to  
input y.

$K_1 t_z$   
to  
input z.



$\sin \theta$ ,  $\cos \theta$  } D.C. VALUES OF VOLTAGE WHOSE RELATIONSHIP IS AS THE SINE AND COSINE OF THE ANGLE  $\theta$

$\sin \phi$ ,  $\cos \phi$  } D.C. VALUES OF VOLTAGE WHOSE RELATIONSHIP IS AS THE SINE AND COSINE OF THE ANGLE  $\phi$ .

$K_1 t_x$ ,  $K_1 t_y$ ,  $K_1 t_z$  } RAMP FUNCTIONS OF VOLTAGE, THE OUTPUTS OF INTEGRATORS X, Y AND Z RESPECTIVELY, WHERE THE CONSTANT  $K_1$  IS A SCALING FACTOR WHICH IS A DEVICE FUNCTION OF THE

GAINS OF DISPLAY AMPLIFIERS OF THE GAINS OF THE INTEGRATING AMPLIFIERS AND ALSO A FUNCTION OF THE AMPLITUDE OF THE INPUT SINE AND COSINE WAVES TO THE INTEGRATORS. FOR SIMPLICITY THESE EFFECTS ARE ACCOUNTED FOR BY THE USE OF THIS "LUMPED CONSTANT"  $K_1$ .

$\sin k_1 t$ ,  $\cos k_1 t$  } SINE AND COSINE WAVE FUNCTIONS WHOSE FREQUENCY (THE HIGH FREQUENCY) IS DETERMINED BY  $K_2$ , AND WHOSE AMPLITUDE IS CONSIDERED TO BE EQUAL TO 1 (ONE UNIT). (FOR A NORMAL MATHEMATICAL

REPRESENTATION WE'D HAVE TO USE "a Sin k\_1 t" TO DENOTE THIS WAVE, BUT WE SIMPLIFY THE EXPRESSION BY LETTING  $a = 1$  unit, which wpx = about 1000th p-p

Lee Harrison

CAPITAL A IS USED TO DENOTE THE VIDEO SIGNAL WHICH COMES FROM THE SKIN SCANNER. THIS IS A WIDE BAND SIGNAL WHOSE UPPER FREQUENCIES ARE VERY HIGH

TO SHOW THE INTER-RELATIONSHIP OF THE VARIOUS SIGNALS, A PICTOGRAPH IS GIVEN BELOW FOR 2 BONES

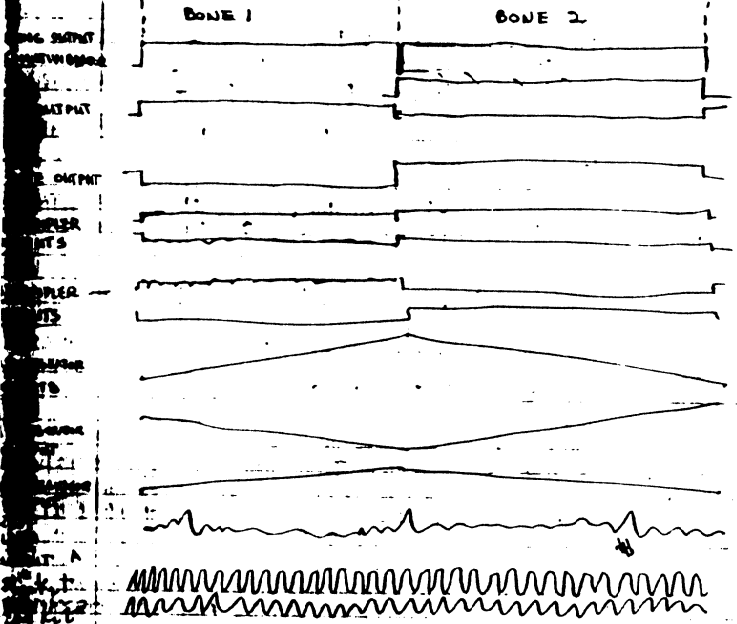

page 16

Lee Harrison

TWO ALGEBRAIC FUNCTIONS ARE PERFORMED BY THE PORTION OF THE DEVICE WHICH WE CALL THE SKIN NETWORK, NAMELY MULTIPLICATION AND ADDITION.



DEC 29 1951

ASSOCIATED WITH EACH MULTIPLIER ARE INPUT AND OUTPUT AMPLIFIERS, WHICH ARE ELECTRONICALLY NECESSARY TO ALLOW AN ANALOGUE MULTIPLIER TO PERFORM THE TASK OF MULTIPLICATION. MULTIPLIERS REQUIRE A "CENTER TAP" INPUT, THUS THE THREE INPUTS TO THE MULTIPLIERS. THE IMPORTANT THING HERE IS NOT HOW WE PERFORM THE PARTICULAR TASK, BUT THAT WE DO PERFORM IT.

ADDER ARE MERELY RESISTOR NETWORKS WHICH ADD THE VARIOUS SIGNALS PRESENTED TO IT.

ALGEBRAICALLY SPEAKING, THE SKIN NETWORK TAKES THE PREVIOUSLY MENTIONED SIGNALS AND COMBINES THEM SO THAT

$$x = k_1 t_x \cos \theta \cos \phi + A \cos \theta \sin \phi \cos k_2 t - A \sin \theta \cos k_2 t$$

$$y = k_1 t_y \sin \theta \cos \phi + A \sin \theta \sin \phi \cos k_2 t + A \cos \theta \sin k_2 t$$

$$z = k_1 t_z \sin \phi + A \cos \phi \cos k_2 t$$

HERE, X, Y AND Z REPRESENT THE VECTORIAL COMPONENTS OF THE FIGURE. BY PRESENTING ANY 2 OF THESE SIGNALS TO THE X AND Y CHANNELS OF A DISPLAY CRT, THE RESULTING DRAWING WILL BE A PROJECTION OF THE 3 DIMENSIONAL FIGURE ON THE PLANE DETERMINED BY THE COMPONENTS SELECTED, BY THE GEOMETRIC SELECTION AND COMBINATION OF ALL THREE OF THESE COMPONENTS, ANY VIEW OR PROJECTION OF THE 3 DIMENSIONAL FIGURE MAY BE SHOWN

## CAMERA-ANGLE NETWORK

THE FUNCTION OF THE CAMERA ANGLE NETWORK IS TO ALGEBRAICALLY (AND THUS GEOMETRICALLY) COMBINE THE X, Y, AND Z COMPONENTS OF THE TARGET DIMENSIONAL FIGURE IN SUCH A MANNER AS TO ALLOW FOR THE PRESENTATION OF ANY PROJECTION OR VIEW OF THE FIGURE WHEN THE OUTPUTS OF THIS NETWORK ARE PRESENTED TO THE X AND Y CHANNELS OF A DISPLAY CRT.

2 ALGEBRAIC FUNCTIONS ARE PERFORMED: THE FIRST IS MULTIPLICATION BY A CONSTANT, THE SECOND IS ADDITION.

THE "MULTIPLICATION BY A CONSTANT" IS, IN EFFECT THE "TAKING OF THE SINE AND COSINE" OF THE VECTOR AND IS ACCOMPLISHED BY A NETWORK OF VARIABLE "SINE-COSINE" POTENTIOMETERS. ADDITION IS PERFORMED USING A FIXED RESISTANCE NETWORK.

ANGLES  $\Theta'$  (THETA PRIME) AND  $\Phi'$  (PHI PRIME) REPRESENT THE ROTATION OF THE XY PLANE ABOUT THE X AXIS AND THE XZ PLANE ABOUT THE Z AXIS.

2 SIN-COSINE POTS GANGED TOGETHER (WITH WIRES A COMMON SHAFT) IS THE MECHANISM FOR PERFORMING THE PROPERLY-RELATED MULTIPLICATION BY CONSTANTS, OR TAKING THE SINES + COSINES IN THE PROPER RELATIONSHIP.

THERE ARE TWO SUCH MECHANISMS. ROTATION OF THE SHAFT OF ONE, CONTROLS THE VIEWING ANGLE  $\Theta'$ . THE OTHER CONTROLS  $\Phi'$ . AMPLIFIERS ASSOCIATED WITH THE NETWORK OF SINE-COSINE POTS ARE AN ELECTRONIC NECESSITY.

THE TWO OUTPUTS OF THIS NETWORK ARE FED INTO THE X AND Y CHANNELS OF THE DISPLAY CRT, AND REPRESENT THE BEAM-POSITIONAL INFORMATION NECESSARY TO DRAW THE

page 18

Dr. Harman

EVENTUALLY, WE'LL USE CONTROLLING SERVO-MOTORS TO POSITION THE SHAFTS  $\Theta'$  +  $\Phi'$ , SO THAT THE CAMERA ANGLES MAY BE RECORDED ON THE CONTROL-TAPE RECORDER ALONG WITH OTHER CONTROLLING INFORMATION. IN OTHER WORDS, WE'LL RECORD SIGNALS TO WHICH THE SERVOS WILL REACT, THUS RECORPING THE CAMERA ANGLES.



DEC 29 1961 AM





1/  
Recording Network (Tape Recorder)

The function of the recording network is to record the joined-together signals (multiplexed angle signals) and allow for the play-back of these signals. The recorder is a multi-channel recorder. On one channel is recorded the clock frame signals for synchronization. Sound is recorded on the selective recording of individual gate-widths or groups of gate-widths is accomplished with recording gates which are activated (opened) by the multivibrators associated with the bone gates desired to be recorded. A switch may be employed to hold these recording gates opened if it is desired to record all of the bones. (As an operator plays the tape, the write heads are ~~upstream~~ <sup>downstream</sup> first, then on to the "upstream" from the read heads as far as tape motion is concerned, the signals which are passed by the recording gates are then recorded on the tape by the write heads. The signals thus recorded are almost immediately read by the "read" heads which the signals are amplified and sent into the bone generation network.

THE TAPE FORMAT IS SHOWN BELOW  
WRITE (RECORD) READ (PLAYBACK)

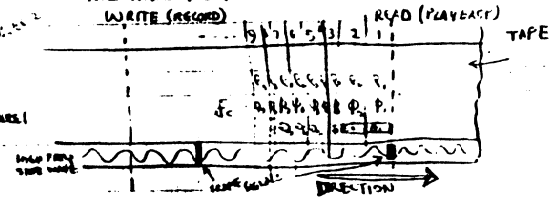

page 22

Edman 177

THE CLOCK CHANNEL HAS RECORDED ON IT THE HIGH FREQUENCY SINE WAVE PLUS THE INTERMITTANT FRAME PULSE. THESE SIGNALS ARE SEPARATED AFTER READING, AND THE SINE WAVES ARE SENT TO THE BONE GENERATOR & THE FRAME PULSES ARE SENT TO THE COUNTER CHAIN.

AFTER THE  $\odot$  AND  $\ominus$  CHANNELS ARE FILLED WITH RECORDED SIGNALS, SELECTIVE RE-RECORDING IS ACCOMPLISHED BY MAKING CONNECTIONS BETWEEN THE SELECTED MSMV'S & THE RECORDING GATES, SO THAT THE GATES ARE OPENED ONLY DURING THE TIMES OF OCCURRENCE OF THE OPENING OF THE  $\odot$  +  $\ominus$  GATES ASSOCIATED WITH THE SELECTED MSMV'S. (THE INITIAL RECORDING SWITCH IS OPENED)

FOR EXAMPLE, SUPPOSE AN OPERATOR WISHED TO RE-RECORD THE ANGULAR ACTIONS OF THE 4th + 5th BONES. HE'D CONNECT THE PULSED OUTPUT OF MSMV'S # 4 + 5 TO THE RECORDING GATE ACTUATING INPUT TERMINAL OF THE RECORDING GATE. THIS THE ONLY TIME RECORDING WOULD TAKE PLACE WOULD BE AT THE EXACT SPOTS ON THE TAPE THAT CORRESPONDED TO THE PREVIOUSLY RECORDED ACTIONS OF BONES 4 + 5, THE WRITE HEAD IN BEING ACTIVATED AT THOSE TIMES WOULD OBLITERATE THE PREVIOUSLY RECORDED SIGNALS AND LEAVE THE NEWLY DESIRED SIGNALS ON THE TAPE, THE REST OF THE TIME, THE RECORDING GATES ARE CLOSED. THE READ HEADS PICK UP THE OLD AS WELL AS THE NEW SIGNALS, AND TRANSMIT THEM THROUGH THE DEVICE TO STIMULATE THE DESIRED ACTION ON THE DISPLAY.

OTHER TAPE CHANNELS ARE USED IN SIMILAR FASHION TO RECORD AND CONTROL OTHER PARAMETERS OF THE BONE. FOR EXAMPLE, THE  $\rho$  (RHO) CHANNEL IS USED TO CONTROL THE ROTATIONAL POSITION (FOR TWIST)

\* OF THE SKIN R-170 9/1961M

# CONTROL OF MOTION & OTHER PARAMETERS OF THE SIGNAL RELATIVE TO THE BONE AXES

BY CONTROLLING THE ~~THE~~ VOLTAGE ~~INPUTS~~ <sup>INPUTS</sup> TO THE BONE GATES, THE POSITIONS, ATTITUDES, <sup>OR ORIENTATIONS</sup> AND OTHER SPACIAL <sup>OR ORIENTATIONAL</sup> PARAMETERS ARE CONTROLLED. THE FUNCTION OF THE CONTROL IS TO GENERATE THE DESIRED SIGNALS FOR THE VARIOUS MOTIONS. IN GENERAL, THE CONTROLLING SIGNALS ARE VERY LOW FREQUENCY <sup>AND IN SOME</sup> CASES PRACTICALLY D.C. (THE SAMPLING RATE FOR EACH BONE SIGNAL TO BE MULTIPLEXED IS 24 TIMES PER SECOND. IN ONE SECOND, UNLESS THE ACTION OF A BONE IS VERY SWIFT, THE VOLTAGE VARIATION FROM THE BEGINNING TO THE END OF ONE DRAWING CYCLE (30  $\mu$ sec) OF ONE BONE ( $\approx \frac{1}{24}$ ) IS VERY SLIGHT. THAT IS TO SAY, SUPPOSE THE VOLTAGE VARIES 5 VOLTS IN ONE SECOND, THE VARIATION DUE TO THE TURNING OF A POTENTIOMETER, THEN THE VARIATION FROM THE BEGINNING TO THE END OF A BONE IS ABOUT  $\frac{1}{24}$  VOLTS WHICH IS SUCH A SMALL CHANGE THAT THE BONE APPEARS STRAIGHT.)

NETWORKS OF VARIABLE RESISTORS AND VERY ~~LOW~~ <sup>LOW</sup> FREQUENCY GENERATORS MAY BE USED TO GENERATE INTERRELATED BONE-GROUP ACTIONS OR MOTIONS. AS THE MANIPULATION OF THE POTENTIOMETER INPUTS IS SIMPLIFIED, IT MAY BE CONSIDERED THAT THE CONTROLS MAY BECOME MORE AND MORE COMPUTER-LIKE, WHERE MANY <sup>SOME</sup> MOTION FUNCTIONS ARE GENERATED AUTOMATICALLY.

~~THE~~ <sup>CURVED</sup> BONES MAY BE ~~GENERATED~~ <sup>GENERATED</sup> BY PUTTING SHAPED WAVEFORMS IN PLACE OF D.C. <sup>INPUTS</sup> ~~INPUTS~~ WILL GIVE BONES OTHER THAN STRAIGHT. FOR EXAMPLE, A SAWTOOTH CONTROL INPUT WILL ~~GIVE~~ <sup>GIVE</sup> A WIGGLY 

Luckman



DEC 29 1961

A SINUSOIDAL INPUT ~~WILL~~ (IF AT THE PROPER PHASE & FREQUENCY) ~~WILL~~ MAKE A CIRCULAR BONE; A ~~SQUARE~~ SQUARE (TYPE) WAVE INPUT WILL MAKE A ZIG ZAG  OR SAWTOOTH TYPE BONE; A RAMP INPUT TO THE BONE GATES WILL MAKE A CURVED OR ARCHED BONE.

SPECIAL WAVEFORMS MAY ALSO BE INSERTED WITHIN BEFORE OR AFTER THE INTEGRATOR, WITHOUT PASSING THROUGH THE <sup>COMPARISON</sup> SAMPLING NETWORKS. IN ORDER TO PRODUCE DESIRED MUTATIONS ON THE BONES (TECHNIQUES SUCH AS THESE HAVE BEEN DISCUSSED ON MANY OCCASIONS, AND WILL BE EXECUTED WHEN TIME ALLOWS) 

JOY-STICKS & FINGER CONTROLS HAVE BEEN DESIGNED FOR EASY, MECHANICAL MANIPULATION OF THE CONTROLS & MAY BE THE SUBJECTS OF LATER PATENTS. SPECIAL <sup>CONTROLS</sup> INPUTS FOR FACIAL EXPRESSIONS MAY BE ~~THESE~~ TRANSDUCED FROM ACTUAL FACIAL & LIP MOTIONS USING A NETWORK OF STRAIN GAGES

## SHADING (AND COLOR) NETWORK

Leathner 11

11/29/61

THE ELECTRONIC SIGNALS COMING OUT OF THE CAMERA ANGLE NETWORK ARE BEAM-POSITIONING SIGNALS; (JUST AS FINGERS CONTROL THE POSITION OF A PENCIL ON PAPER). THE FUNCTION OF THE SHADING (AND COLOR) NETWORK IS TO GOVERN THE BEAM INTENSITY AS IT DRAWS THE FIGURE OR OBJECT, ~~AND IS GOVERNED BY THE~~ ~~THE SPEED~~ (HIGH FREQUENCY) VARIATIONS IN INTENSITY ASSOCIATED WITH SKIN SHADES & SHADOWS, TEXTURES ~~etc.~~ etc. WHICH ARISE FROM THE SURFACE VARIATIONS IN THE SKIN. (COLOR VARIATIONS IN THIS SENSE ARE THOUGHT OF IN TERMS OF A THREE-COLOR (MULTI-COLOR) PROCESS WHERE FOR EXAMPLE <sup>(THREE DISPLAY SCOPE) (THREE DISPLAY SCOPE)</sup> THREE DISPLAY SCOPES, ARE OPTICALLY SUPERIMPOSED, AND EACH SCOPE HAS A COLOR FILTER ON ITS FACE. BY VARYING THE INTENSITIES OF THE 3 BEAMS, THE ~~OPTICAL~~ OPTICAL IMAGE HAS FULL SPECTRUM COLOR CAPABILITY. THIS TOPIC IS CALLED SHADING (AND) COLOR NETWORK.)

THE SKIN VIDEO SIGNAL CONTAINS THE INFORMATION ABOUT THE ~~ORTHOGONAL DISTANCE BETWEEN BONE AND SKIN.~~ <sup>ORTHOGONAL DISTANCE BETWEEN BONE AND SKIN.</sup> IN THE FULL BASIC FORMAT, THE RATE OF CHANGE OF THE VIDEO SIGNAL IS USED TO <sup>CONTROL HIGH</sup> FREQUENCY SKIN VARIATIONS TO ACCENTUATE ~~SKIN~~ SKIN FEATURES WHICH OCCUR BETWEEN THE EDGES OF THE OBJECT BEING DRAWN IN THIS FORMAT. BY DIFFERENTIATING THE SKIN VIDEO A RATE-OF-CHANGE SIGNAL IS OBTAINED. A THRESHOLD NETWORK DETECTS ALL RATES <sup>OF CHANGE</sup> ABOVE OR A PRESCRIBED ABSOLUTE VALUE. THE CLIPPED OUTPUT OF THE THRESHOLD NETWORK IS AMPLIFIED AND SCANNED, ~~THENCE~~ THENCE USED TO MODULATE BEAM INTENSITY, ~~AND~~ ~~EDGING~~, EDGE EFFECTS (EDGE SHADOWS ETC.)

page 26

Leathner 11

ARE PRODUCED IN ACCORDANCE WITH THE SKIN VECTOR POSITION WHICH IS A FUNCTION OF THE PHASE OF THE HIGH FREQUENCY SINE WAVE FROM THE CLOCK. IN ADDITION, A HIGH FREQUENCY WOBBLE OR A FOCUS-FLARE MAY BE EMPLOYED TO HEAVY-UP OR THICKEN THE EDGES, THIS ACTION ALSO BEING IN SYNCHRONISM WITH PHASE OF THE SINE WAVE.

DO NOT VARY WITH FLAT COLOR EFFECTS, OR GRAYS OR TEXTURES WHOSE BONE POSITION, MAY BE PRODUCED BY GATING IN THESE INTENSITY MODULATING SIGNALS ~~AS A FUNCTION OF~~ THE BONE GATES DESIGNED FOR THAT PURPOSE. THE INPUT TO THE GATES <sup>IS</sup> A HIGH FREQUENCY OF A CERTAIN PATTERN WHICH WHEN APPLIED TO MODULATE THE BEAM INTENSITY DURING THE DRAWING OF A PARTICULAR BONE WILL GIVE A TEXTURED PATTERN. MORE SPECIFICALLY, VIDEO SIGNALS CONTAINING DESIGNS OF PRESCRIBED DESIGNS MAY BE APPLIED IN THIS MANNER TO GIVE THE DESIRED EXTERIOR APPEARANCE OF AN OBJECT ~~AS A SOAP BOX OR OTHER CONSUMER PRODUCT, OR A SHIRT PATTERN (ON A FIGURE) OR A HAIR PATTERN (ON AN ANIMAL CHARACTER)~~ (TO GENERATE THIS INTENSITY VIDEO, ANOTHER SCANNER WOULD BE REQUIRED, OR A SPLIT-IMAGE SCANNING TECHNIQUE WHERE OPTICAL MEANS <sup>(OR MULTIPLE FILTERS)</sup> ARE USED TO HAVE THE SKIN-SCANNING MASTER OF THE FLYING SPOT FOCUSED ON TWO (OR MORE) FILMS - WHERE ONE FILM CONTAINS THICKNESS INFORMATION AND ANOTHER CONTAINS SURFACE COLOR, PATTERN OR TEXTURE INFORMATION.

## OVERLAP PREVENTION AND SCAN CONVERSION

BECAUSE THE DISPLAY BEAM IS DRAWING A 2-DIMENSIONAL PROJECTION OF A 3-DIMENSIONAL IMAGE IN A CONTINUOUS MANNER IT IS NECESSARY TO PROVIDE A MEANS OF PREVENTING THE BEAM FROM DRAWING OVER A PORTION OF THE IMAGE WHICH HAS ALREADY BEEN DRAWN. THIS A SPECIAL DEVICE FOR "OVERLAP PREVENTION" HAS THE FUNCTION OF DOING AWAY WITH "GHOST" IMAGE OR ~~AND~~ OVERLAP.

OVERLAP MAY BE CLASSIFIED ~~AS~~ INTO TWO TYPES. ONE TYPE OCCURS WHEN THE "BACK PART" OR PART OF THE IMAGE ON THE SIDE AWAY FROM THE VIEWER IS DRAWN. THIS OVERLAP IS PREVENTED BY TURNING OFF THE INTENSITY OF THE BEAM ACCORDING TO THE VECTORIAL POSITION OF THE SPIN VECTOR WHICH IS A FUNCTION OF 1) PHASE OF THE HIGH FREQUENCY, AND 2) THE CAMERA ANGLE (WHICH GOVERNS THE POSITION OF THE PLANE OF PROJECTION).

THE 2<sup>ND</sup> TYPE OF OVERLAP OCCURS WHEN ONE PART OF AN OBJECT OR FIGURE OVERLAP ANOTHER PART, OR WHERE ONE FIGURE IS IN FRONT OF ANOTHER. BY USING A SPECIAL DISPLAY TUBE WHICH HAS IN IT, TWO OR MORE ELECTRON GUNS, ONE OF WHICH IS A "WRITE" GUN, ANOTHER OF WHICH IS AN "ERASE" GUN (HAVING SELECTIVE ERASURE CAPABILITY). AND HAVING THE ERASE GUN PRECEDE THE WRITE GUN BY EMPLOYING A SLIGHT DELAY IN THE WRITE SIGNALS (BOTH GUNS GETTING THE SAME <sup>POSITIVE</sup> DISPLAY SIGNALS HOWEVER) OVERLAP MAY BE PREVENTED, AS LONG AS THE ~~OVERLAP~~ OBJECT OR PART OF THE OBJECT WHICH IS TO BE DISPLAYED IS DRAWN IN THE ~~THE~~ LAST SEQUENCE COMPATIBLE WITH THIS METHOD (NAMESLY, LAST

26

A MULTI-GUN SCOPE THUS EMPLOYED WILL CONTAIN THE IMAGE THUS DRAWN FOR A LENGTH OF TIME ~~COM~~ NECESSARY FOR PHOTOGRAPHING OR SCAN CONVERTING. A SCAN CONVERSION TUBE MAY BE USED TO ~~TO~~ <sup>TRANSFER</sup> THE ~~IN~~ DRAWN IMAGE INTO A SCANNING PATTERN WHICH IS COMPATIBLE WITH TELEVISION TRANSMISSION OR A CLOSE-LINE RASTER WHICH WOULD BE COMPATIBLE FOR THE SUPERPOSITION OF FIGURES ON A BACKGROUND.

AT THIS POINT IN THE GENERATION OF ANIMATED PICTURES IT IS NECESSARY TO CONSIDER PICTURE QUALITY IN TERMS OF RESOLUTION. THE PROBLEM OF RESOLUTION BECOMES ACUTE WHEN HIGH ~~SPEED~~ SCANNING SPEED ~~REQUIRES~~ NECESSITATES HIGH BANDWIDTH REQUIREMENTS. THUS IT IS CONTEMPLATED THAT THE SPECIAL PICTURE TECHNIQUES (SUPERIMPOSITION-OVERLAP PREVENTION-SCAN CONVERSION) WILL BE CARRIED ON AT A RELATIVELY SLOW RATE - i.e. NOT AT THE SAME SPEED AT WHICH WE ANIMATE. AN OPERATOR MAY DO HIS ANIMATION ~~IN~~ REAL TIME (WHERE THE DEVICE ~~PUTS~~ THE SIGNALS INTO A 24/FRAME/SEC FORMAT) BUT THE EVENTUAL FILM-RECORDING OF THE ANIMATED SEQUENCES WILL BE AT A SLOWER RATE, AND OF COURSE ALL AUTOMATICALLY CONTROLLED BY THE PRE-PROGRAMMED ANIMATION WITH LOW, REPRODUCTION + SCANNING RATES, HIGH RESOLUTION, COMPATIBLE WITH 35MM. FILM GRAIN MAY BE ATTAINED,

## THE MAGICAL EYE (1969)

Peter Weibel in THE MAGICAL EYE, an expanded movie by Valie Export and Peter Weibel.

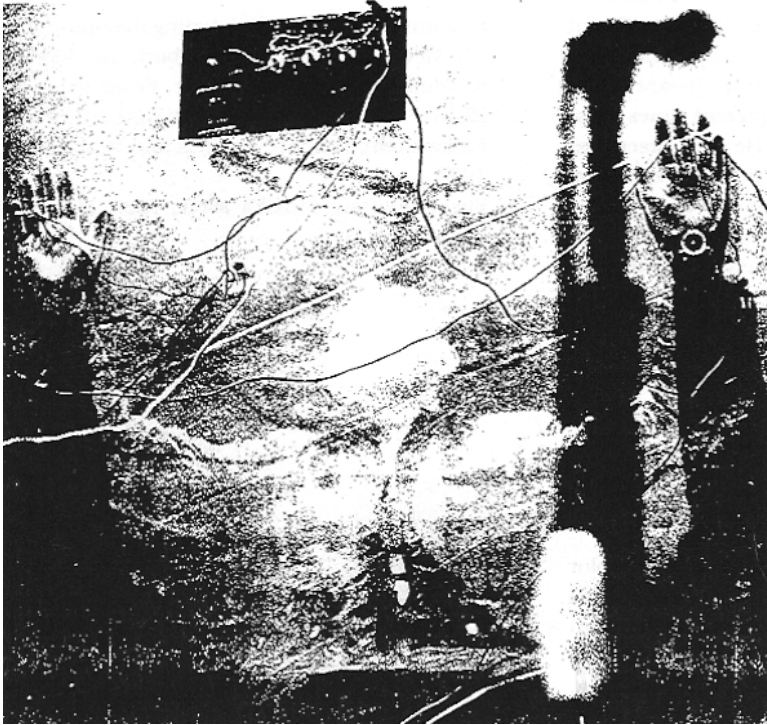

Normally sound is produced in the projector with the optical sound method developed by Vogt, Engel and Masolle in the 1920s. The frequency of sound is converted into light fluctuations which influence the light-sensitive film strip moving by at a constant speed. When the film is shown, the light of the projection lamp is modulated by the fluctuations in brightness recorded on the edge of the film strip and translated into sound through a photo cell. In the MAGICAL EYE the sound is produced on a screen equipped with photo cells and relays. The light

produces sound which is greatly amplified. The film projected onto this screen consists of abstract patterns: dark patterns result in low sounds and bright patterns result in high sounds. The light valence is not measured as the sum of the whole surface since the individual pulses of diverse cells are added depending on how the light falls on them. The powerful sound collage that results is produced through the interaction of the light from the film, the light of the surrounding space and the action of the audience.



